



ANVÄNDAR INSTRUKTION



Detta är en instruktion som är avsedd för den som ska installera vågen och användaren.

Normalt levereras indikatorn i kombination med en vågplatta i olika kapaciteter och heter då JBJP JIK. Den är kalibrerad och klar och delarna är bara att sätta ihop. Sidorna 1 – 5 i denna instruktion är på svenska och vad som normalt levereras med vågen/indikatorn.

Den fullständiga användarinstruktionen kan laddas hem på www.vetek.se. Där finns också en komplett Service manual på engelska. Den är i huvudsak avsedd för den som ska gå djupt in i informationen och göra grundläggande inställningar.

Vågindikator JIK-6 är en mycket noggrann och prisvärda vågindikator. Den kan med fördel användas för generella applikationer inom vägning. Alla inställningar sker via knappar i panelen. Indikatorn har som option reläutgång, datautgång för utprintning eller datakommunikation. Indikatorn är monterad i en ABS apparatlåda med kapsling IP65. Den kan monteras på vägg eller bord.

Typiska användningsområden är: De flesta vägningsapplikationer, bords och golvvågar, mm. Speciellt där man vill ha flera förinställbara taravikter och enkel räknefunktion.

SPECIFIKATIONER

Spänningsmatning:	Batterieliminatör 230 VAC/9 VDC
Matning till lastcell:	5 VDC. Driver upp till 8 st lastceller.
Max extern upplösning:	30.000 delar.
Räkning:	Minsta detalj att räkna bör vara minst 0,8 x graderingen.
Display upplösning:	Upp till 30.000 (internt 5.000.000)
Indikeringar:	6 st siffror 30 mm bakgrundsbelysta LCD
Frontfunktioner:	Nollställning, Reset, Print
Dimension:	B230, H150, D90 mm (Vikt 2,8 kg)
Option	RS232, 1 st reläer, Printer, Rostfri kapsling, mm.



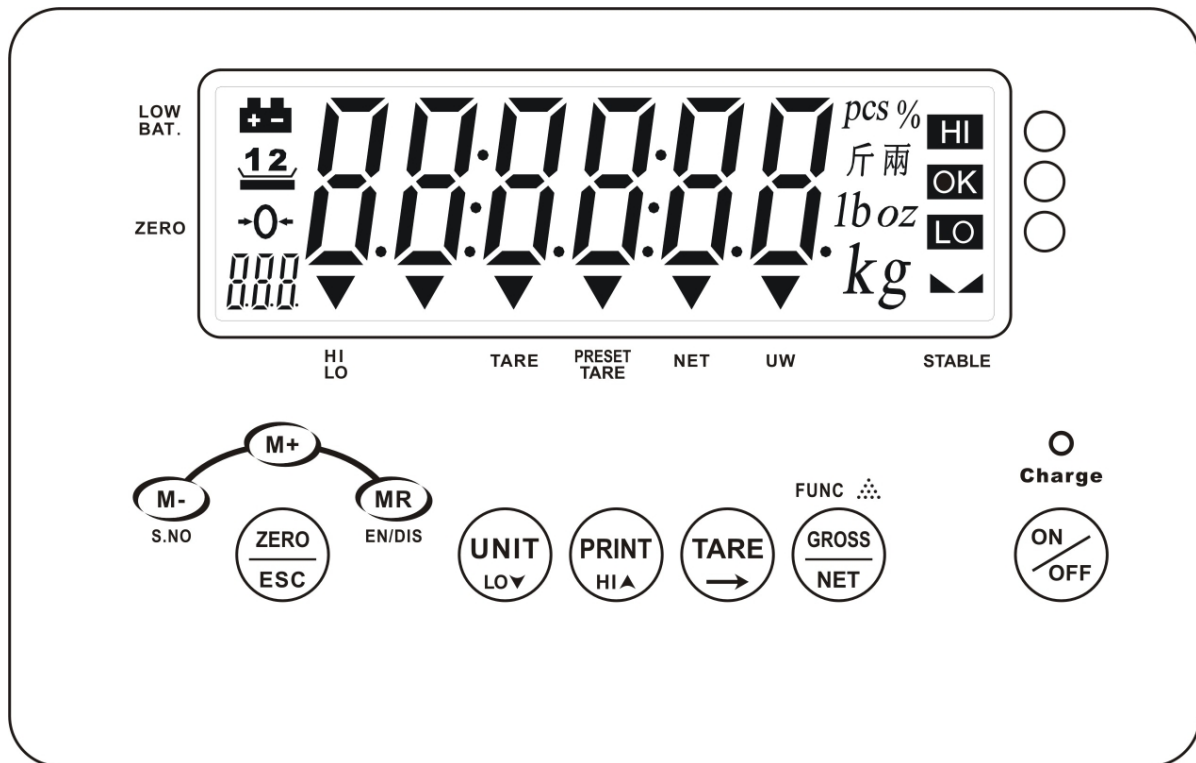





LCD displayen



LCD displayen och förklaringar

LCD display	Explanation
<i>kg</i>	Vägningsenhet i Kilo och gram
-0-	“ Noll ” symbol
▼	Stabilsymbol när viktsvärdet är stabilt.
<i>pcs</i>	Räknefunktion
%	Procentfunktion
▼	Indikering för liten provvikt vid räkning, nettovikt, tara, för-tara, hög/lågvikt, auto tara.
000	Funktions meddelande display
HI OK LO	Hög, okay och låg-indikering
<i>lb oz</i>	Alternativa vägningsenheter
+	Dåligt batteri

Tryckknappar med förklaringar (De viktigaste är fetmarkerade)

Position	Knapp	Huvudfunktion	Sekundär funktion
		Indikator Till / från	
1		Ta bort ackumulerade värden eller antal ackumulerade vikter.	<ol style="list-style-type: none"> 1. Ändra siffra i parameter mode (minska). 2. Ändra värden i HI-LO checking mode. 3. Ändra serienummer. 4. Skriva in datum och tid
2		Akkumulering	<ol style="list-style-type: none"> 5. Ändra siffra i parameter mode (öka). 1. Ändra värden i HI-LO checking mode. 2. Tryck för att komma till "testing mode". 3. Ändra inställning i "accumulation mode".
3		Nollställa displayen.	<ol style="list-style-type: none"> 1. Tryck för att komma ifrån en parameter utan att spara. 2. Annuleringsfunktion.
4		Visa totalt ackumulerade vikter och dess antal.	<ol style="list-style-type: none"> 1. Till eller ifrån "HI-LO checking function". 2. Kapacitet / gradering inställning
5		Koppla om mellan olika vägningsenheter.	<ol style="list-style-type: none"> 1. Gå till inställning av vägningsenhet. 2. Gå till "HI-LO checking mode" och knappar för "LO limits" 3. Inställning av mellanrum vid utprintning.
6		Skickar lagrad viktsinformation till PC eller printer.	<ol style="list-style-type: none"> 1. Gå till "printer mode" 2. Gå till "HI-LO checking mode" och knappar för "HI limits"
7		Tarera	<ol style="list-style-type: none"> 1. Gå till förinställning av taravikt. 2. Flyttar markören till vänster i "parameter setting mode".
8		Växlar mellan Brutto/netto visning.	<ol style="list-style-type: none"> 1. Gå till "internal parameter setting" 2. Lagra provikten i räkne mode. 3. Återställa serienummret i "serial number mode". 4. Gå till "print format setting mode".

Montage



Öppna kartongen och kontrollera att allt är med.



Skruva fast bygel på pelaren.



- Vågplatta
- Skruvar
- Adapter
- Indikator
- Pelare
- Bygel
- Instruktion



Skruva fast pelaren i vågplattan.



Tag bort de två mekaniska stoppen



Tag bort tejen.



Stoppa in kabeln i pelaren



Anslut kabeln och adaptern.

Klart!



Lastcellkontakt

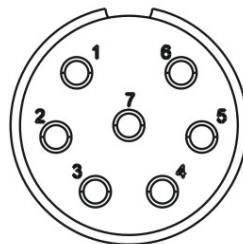
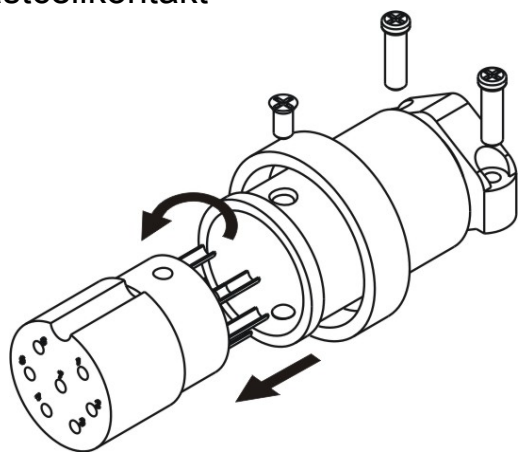





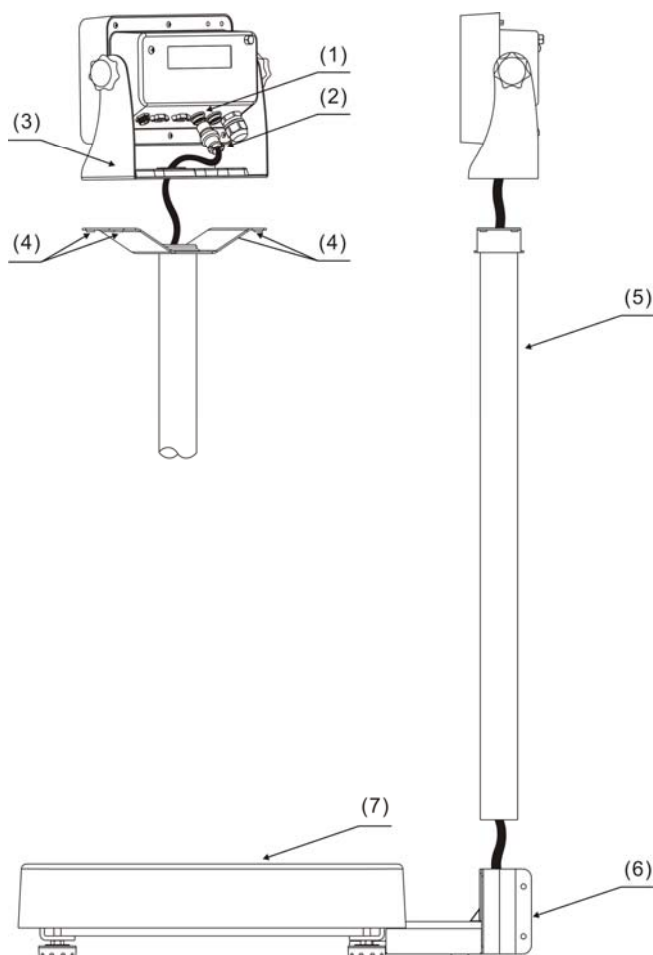

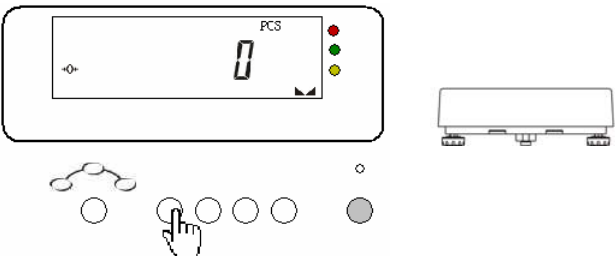

No.		No.	
1	E+	5	S+
2	ES+	6	S-
3	E-	7	GND
4	ES-		

Montage av komplett våg

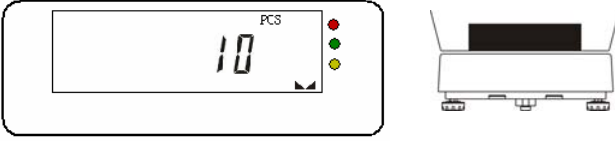
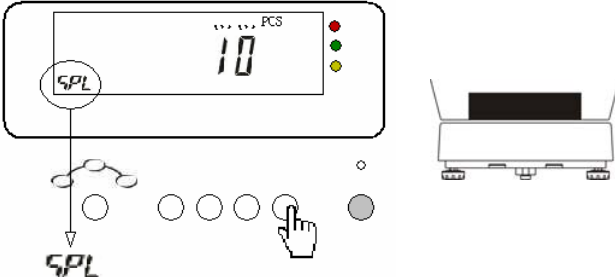

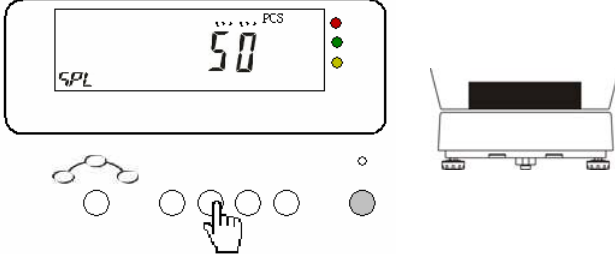
1	Lastcell kontakt, 7 pin hane.
2	Lastcell kontakt, 7 pin hona.
3	Montagebygel
4	Adapter mellan bygel och pelare.
5	Pelare
6	Pelarthållare
7	Plattform

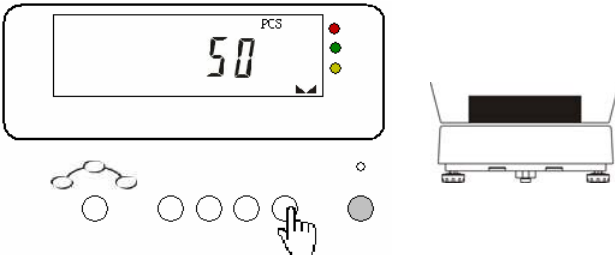
ENKEL RÄKNEFUNKTION

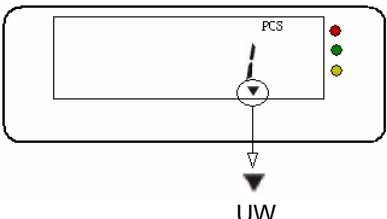
	<p>(1). Tryck på  och välj PCS (styck) som vägningsenhet.</p>
	<p>(2). Lägg på provvikterna på vågplattan. (Välj 10, 25, 50, ell 100 PCS (styck)!) </p>
	<p>(3). Tryck på , displayen visar antalet t.ex 10PCS (blinkande) och displayen visar SPL (provvikt).</p>
	<p>(4). Tryck på  för att välja antal provvikter. T.ex. Om Du väljer t.ex 50pcs (st) som provantal (blinker).</p>
	<p>(5). Tryck på  för att avsluta proceduren. Nu kommer displayen att visa antalet.</p>
	<p>OBS: För att få en bra räkning bör varje enhet väga minst 0,8 x vågens delning. För en 100 kg våg bör enheterna väga minst 8 gram.</p>

PRECAUTIONS

The scale or indicator should always be used in an environment which is free from excessive air currents, corrosives, vibrations, temperatures and humidity extremes. These factors will affect displayed weight readings.

DO NOT use the scale or indicator

Next to open windows or doors causing drafts or rapid temperatures changes! A temperature between 0 ~ 40 degree Celsius is recommended.

Near air conditioning or heat ventilations!

Near vibrating, rotating or reciprocating equipment!

Near magnetic fields or equipment that generates magnetic fields.

On a rough work surface!

Leveling the scale

(when the indicator is connected to a platform)

Always adjust the scale to a level position with level adjusters until the bubbles appear in the center circle of the level indicator!

Battery

Recharged the battery whenever the symbol  is flashing; this indicates that battery level is low. Charge the battery with the DC 9V / 1A adaptor attached. And when the battery is charging, the LED is red and when is fully charged the LED turns green. (it takes approximately 6 hours to charge battery completely)

Installation

Load Cell connections

■ 7 pin Load Cell connections

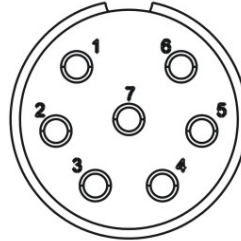
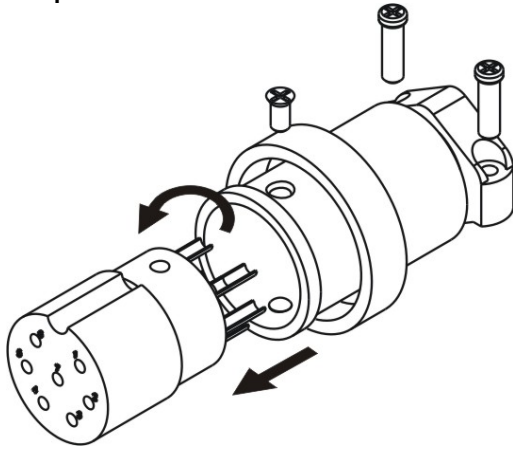

No.		No.	
1	E+	5	S+
2	ES+	6	S-
3	E-	7	GND
4	ES-		

■ Setting up the platform

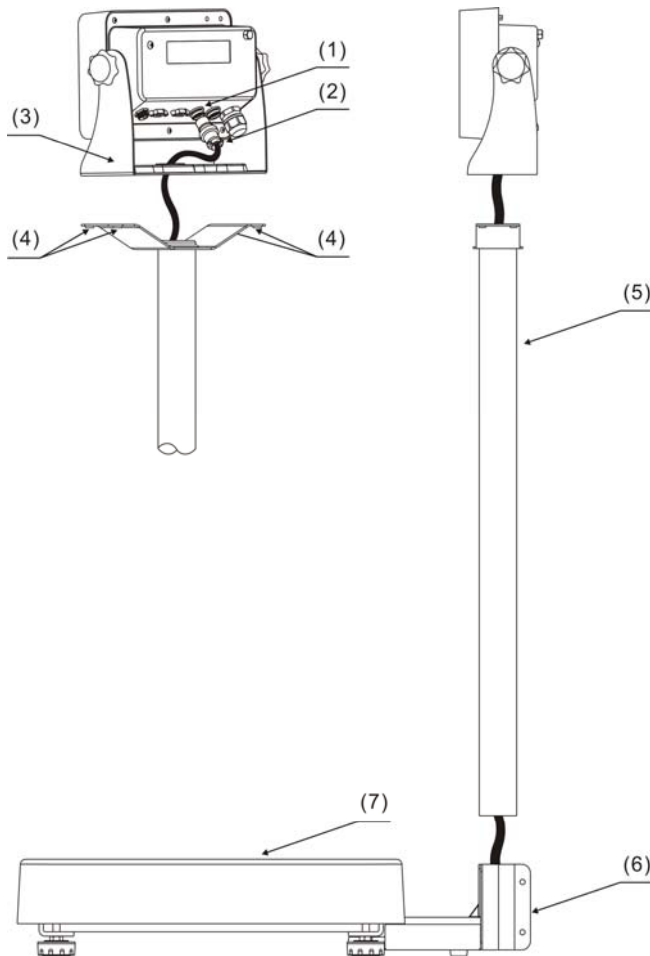

1	Load Cell (male) connector □ 7 pin □
2	Load Cell (female) connector □ 7 pin □
3	Indicator Stand
4	Supporter between frame and indicator
5	Pole
6	Pole holder
7	Platform

■ **Assemble the scale by the following steps (refer to the diagram above)**

1. Pull the load cell cable through pole holder (6) up. Install pole (6) into the pole holder (5), and fix the pole with cross-headed screws.
2. Pull load cell cable through indicator supporter (4) to connect to the indicator.
3. Install Indicator supporter (4) and indicator stand (3) together.
4. Adjust the indicator to adequate viewing angle and tighten the screws located on each side of the Indicator.

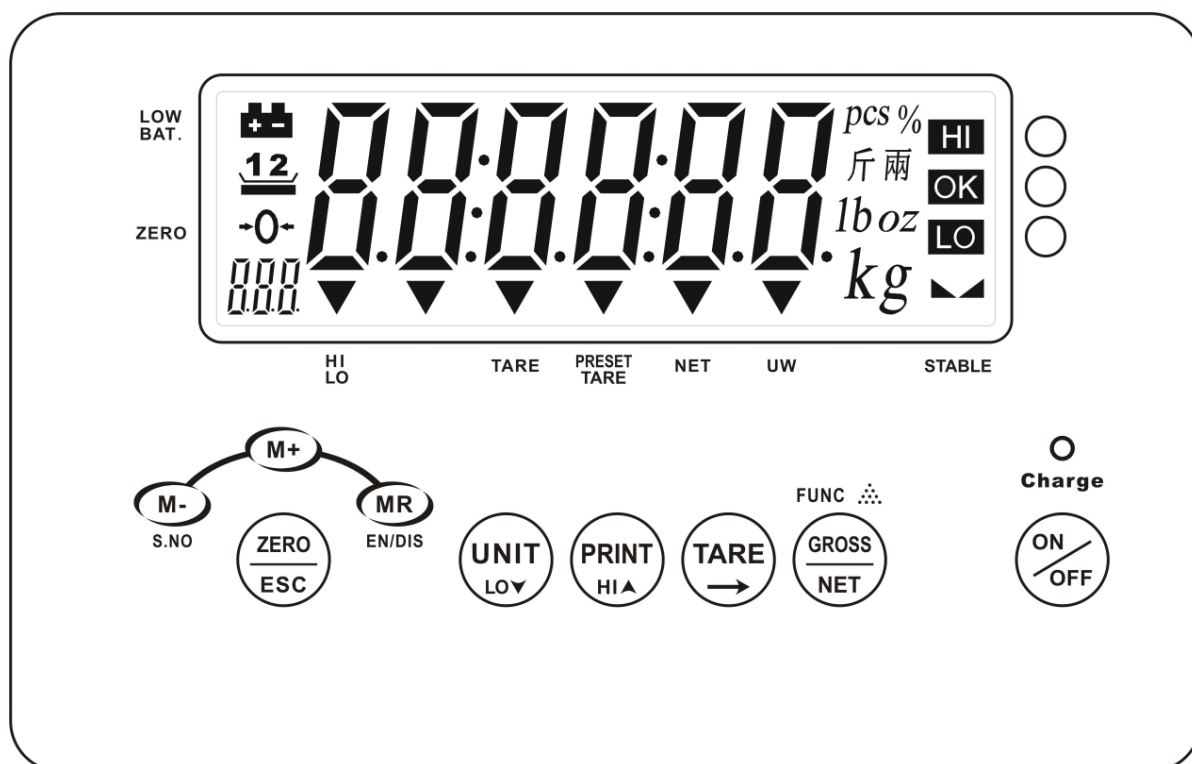

LCD display and function of each key









■ LCD display and explanation



LCD display	Explanation
<i>kg</i>	Weighing unit in Kilograms or Grams
→0←	“ ZERO ” sign
▼	Stable sign when the weight reading is stable
<i>pcs</i>	Piece counting function
%	Percentage function
▼	Indication sign for insufficient unit weight, net weight, tare, pre-tare, Hi-Lo limits, auto tare.
0000	Operation message display
HI OK LO	HI, OK and LO limits indication
<i>lb oz</i>	Additional weighing units
	Battery Power is weak

■ Explanation of each key





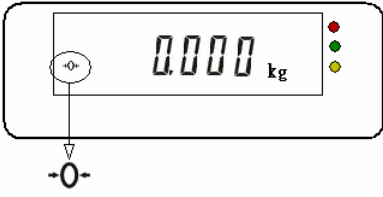
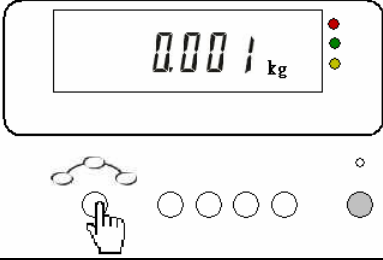

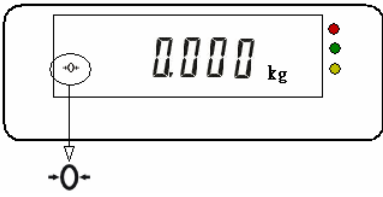
Position	Keys	Main function	Secondary functions
		Turns the indicator on or off	
1		To delete the accumulation weights or certain number of accumulated weight	6. change the digit when in parameter mode (decreased) 7. change the number when in HI-LO checking mode 8. setting of serial number 9. setting of date & time

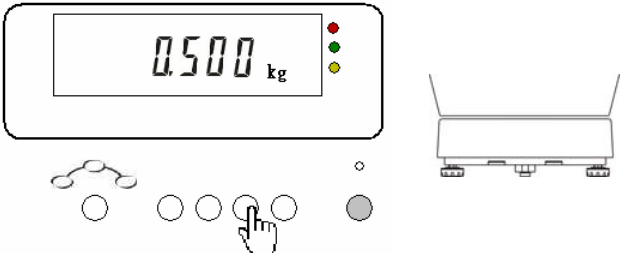

2		Accumulation	<ol style="list-style-type: none"> 4. Change the digit when in parameter model (increased) 5. Change the number when in HI-LO checking mode 6. Press this key to enter the testing mode 7. Change the setting of accumulation mode.
3		Set the display to zero	<ol style="list-style-type: none"> 3. Press to escape from parameter setting without saving. 4. Cancel function
4		Recall total accumulation weights or certain number of accumulated weights	<ol style="list-style-type: none"> 3. Enable or disable the HI-LO checking function 4. Capacity / division setting
5		Switch the weighing unit from one to another	<ol style="list-style-type: none"> 4. To enter to weighing units setting mode 5. To enter into HI-LO checking mode and key in the LO limits 6. Setting the space when in printing format mode
6		Send the data stored in memory to PC or printer when pressed	<ol style="list-style-type: none"> 3. To enter to printer mode 4. To enter into HI-LO checking mode and for key in HI limits
7		Tare	<ol style="list-style-type: none"> 3. To enter to pre-tare mode 4. Move the cursor to left when in parameter setting mode
8		Switch the weight between GROSS/ NET	<ol style="list-style-type: none"> 5. To enter to internal parameter setting 6. Sample storing mode when in piece counting mode 7. Reset the serial number when in serial number mode 8. To enter to print format setting mode

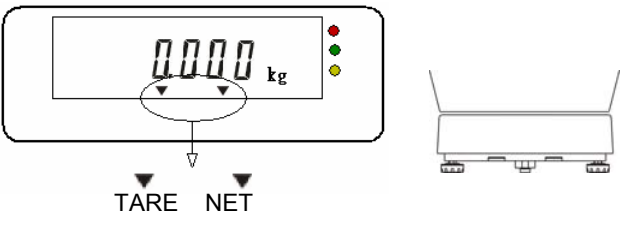
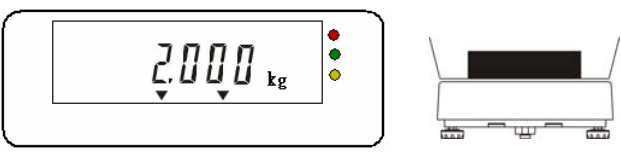
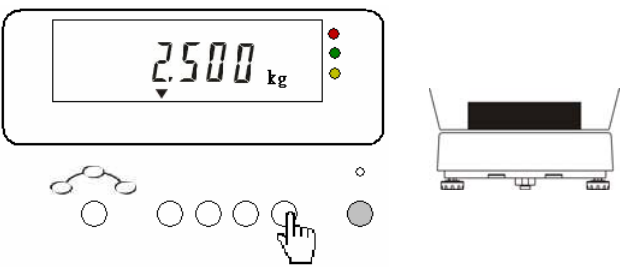
ZERO

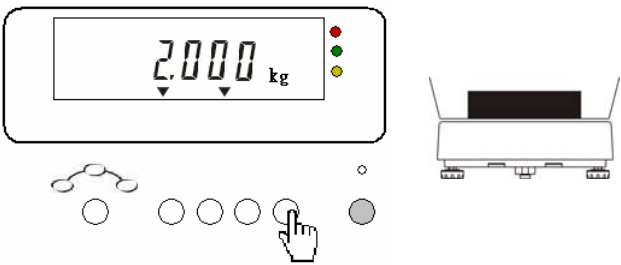

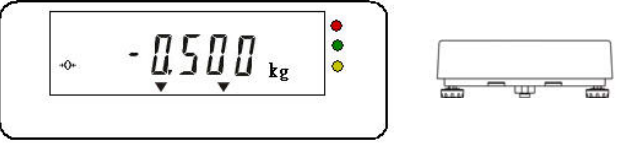

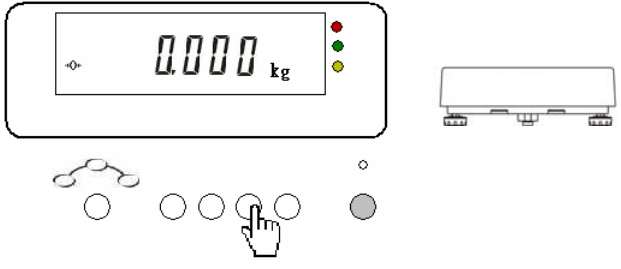



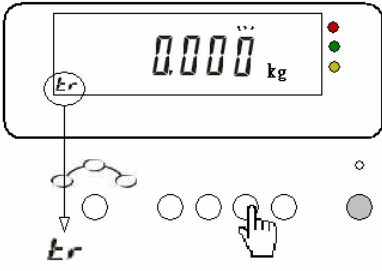

	<p>(1). The indicators zero point -0- sign is shown in the left diagram. When the display is at zero, this sign will appear.</p>
	<p>(2). Press  to return to zero when the display is without the -0- sign.</p>
	<p>(3). Now, the -0- sign appear and the scale is in zero point.</p> <p>Remarks: The range of zero point is +/- 2% of the max capacity. Example : the zero range of 60kg is +/- 1.2kg</p>

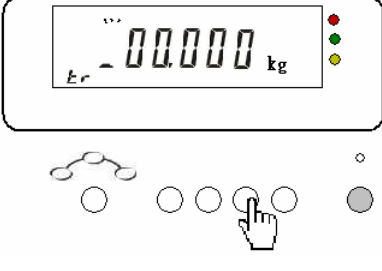

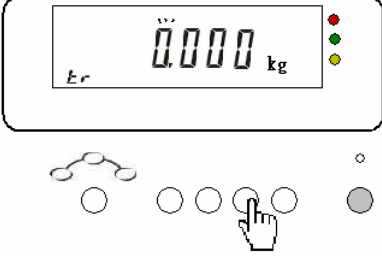

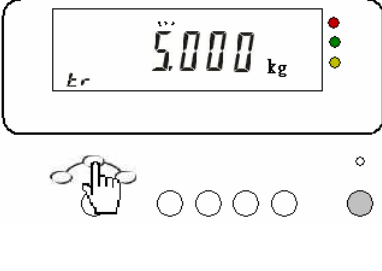
TARE

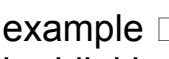
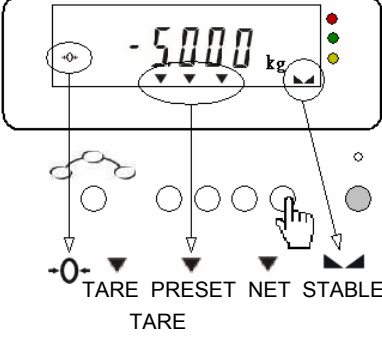
	<p>(1). Place a container, for example 0.500 kg on the weighing pan.</p> <p>(2). Press  key.</p>
	<p>(3). After pressing TARE, indication sign for TARE and NET will appear. The scale is now in net weight condition.</p>
	<p>(4). Place a weight object of 2.00kg into the container. The net weight is reading as 2.000 kg.</p>
	<p>(5). Press  key.</p> <p>(6). Display will show the gross weight as 2.500kg (inclusive of the TARE weight). Net weight sign is disappear.</p>
	<p>(7). Press  again and display will show the NET weight again as 2.000 kg with the sign NET again.</p>
	<p>(8). Remove all objects from the weighing pan and wait for the zero -0- sign to appear.</p>

	<p>(9). Press  key .</p> <p>(10). The NET and TARE signs will disappear and the scale now return to Zero point.</p> <p>Remarks <input type="checkbox"/> Weighing Range = Maximum Range – Tare Range</p>
---	---

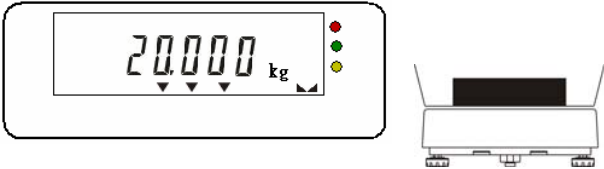
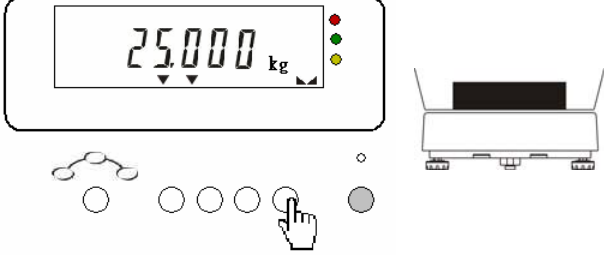
PRE-TARE

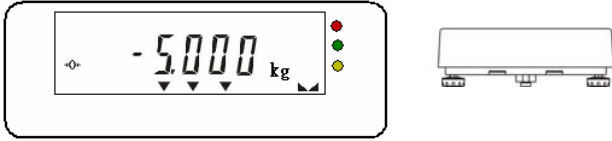
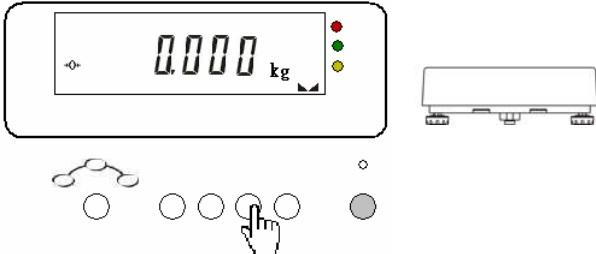
	<p>(1). Under normal weighing mode, press  key for 3 seconds, the display will show the pre-tare mode with last digit flashing. At the operation message display, you can see "Er"</p>
	<p>(2). Press  key to start the setting of the Pre-Tare value . </p>
	<p>(3). Press  key to move the cursor to the desired digit which needs to be changed . Example </p>
	<p>(4). Press  key to change the digit in increasing manner and  key to change the digit in decreasing manner. For example , number 5 will be blinking .</p>
	<p>(5). Press  key to save the pre-tare changes and return to weighing mode .Now the display will show -5.000kg and zero point \, tare, pre-tare, net weight signs \ will appear in display!</p>

	<p>(6). Place the container (5.000kg) and weight mass(20.000kg) to the weighing pan. The display will show 20.000kg, the zero sign will disappear and this 20.000kg will be the Net weight .</p>
	<p>(7). Press  key and now the display will show 25.000kg, arrow pointing to NET disappear. This 25.000kg will be the gross weight of the weight object with the container.</p>
	<p>(8). Remove the container and weight object, display will show -5.000kg again.</p>
	<p>(9). Press  key and all the arrows pointing to NET, TARE, Pre-Tare will disappear. The scale returns to normal weighing mode with the zero sign on.</p> <p>Remarks <input type="checkbox"/> Weighing Range = Maximum Range – Tare Range</p>



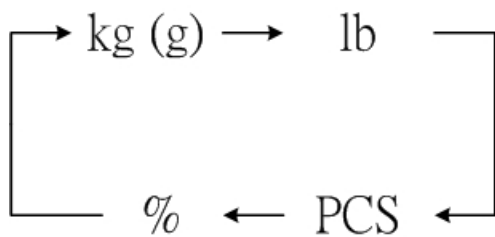







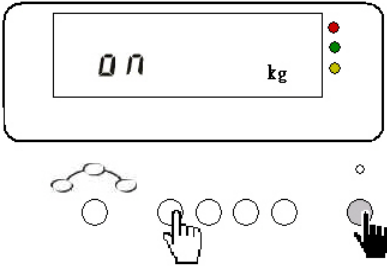

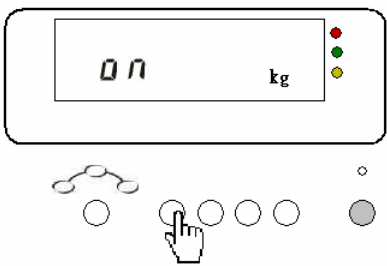
SELECTION OF WEIGHING UNIT

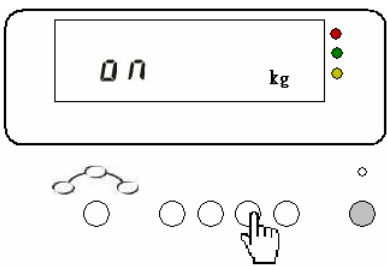

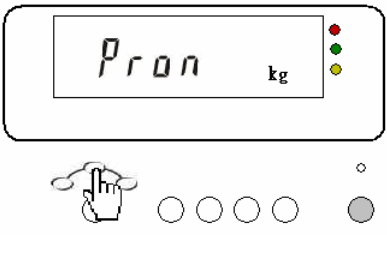
Press  key to select the weighing unit in sequence as shown on the left diagram.

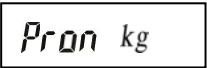
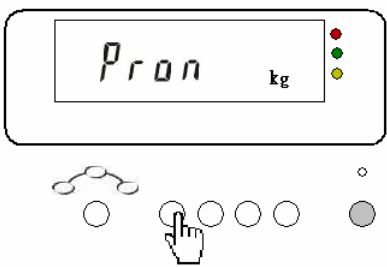
Remarks When using division 1g, the unit will be shown as kg
when using division < 1g, the unit will be shown as g.

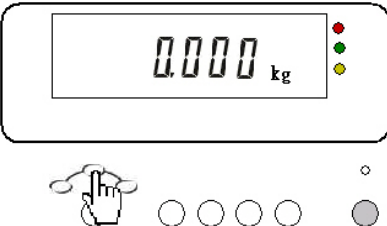
INITIAL WEIGHING UNIT SETTING

	<p>(1). Press  key and turn of the scale at the same time. Display will show </p>
	<p>(2). Press  key for selection of different weighing unit, there are 4 weighing units <input type="checkbox"/>kg<input type="checkbox"/>lb<input type="checkbox"/>pcs<input type="checkbox"/>.</p>
	<p>(3). Use  key to select the weighing unit to be ON (in used) or OFF (not in used)</p>
	<p>(4). Press  key to save changes and display will now show </p> <p>as the initial weighing unit.</p>
	<p>(5). Press  key to choose the desired Unit as the initial weighing unit when turn on the scale.</p> <p>Remark <input type="checkbox"/> The selected weighing unit must be ON(in used) when select for initial weighing unit</p>
	<p>(6). Press  key to save changes and return to normal weighing mode.</p>

ACCUMULATIONS

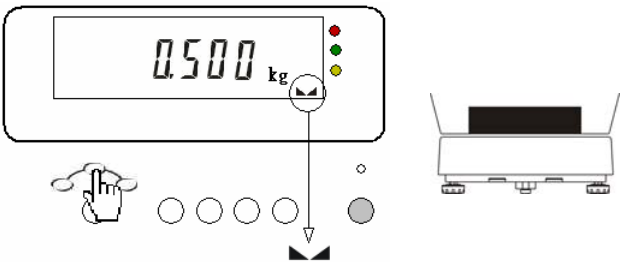
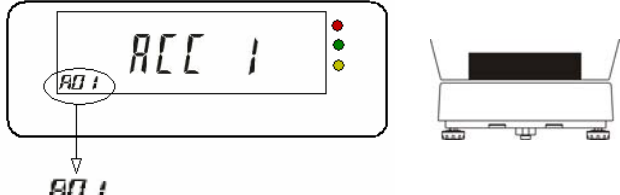
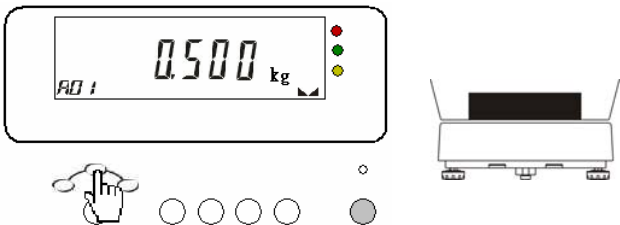
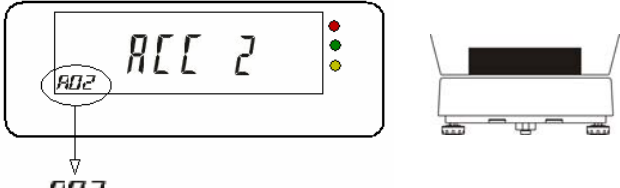
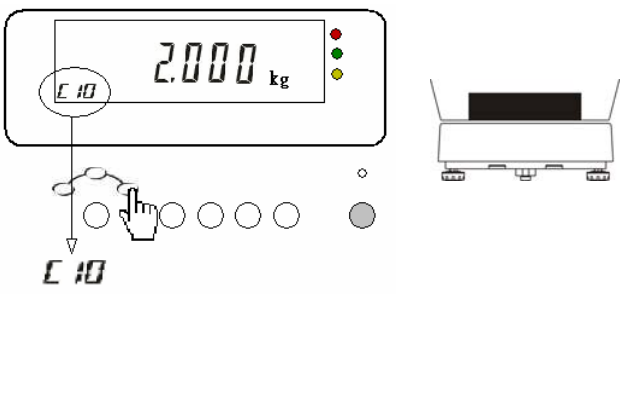
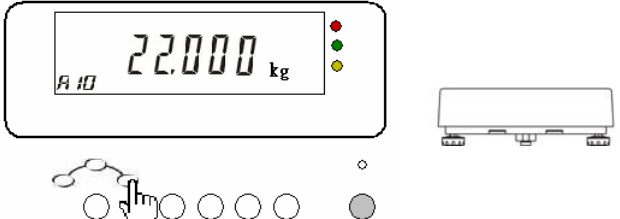
	<p>(1). Place an object on the pan wait for the stable sign and press M+ key.</p>
	<p>(2). Display will show "ACC 1", and also the weight of the object. At the same time, you can see the sign "A01" on the operation message display.</p>
	<p>(3). Remove the first object and place the next object on the pan, press M+ key when stable.</p>
	<p>(4). The display will show "ACC 2" and the weight of the second object. The sign "A02" will appear on the operation message display.</p>
	<p>(5). Repeat procedures 3 and 4, for the desired accumulations</p> <p>(6). Press MR key now, display will show the weight of the last object. The operation message display at left will show $\bar{\bar{}} \times \times$ (flashing). For example if there are 10 accumulations, it will show $\bar{\bar{}} 10$.</p>
	<p>(7). Press MR key again and you will see all the 10 accumulations' total weight. $\bar{\bar{}} \bar{\bar{}}$ indicates all the 10 accumulations!</p>

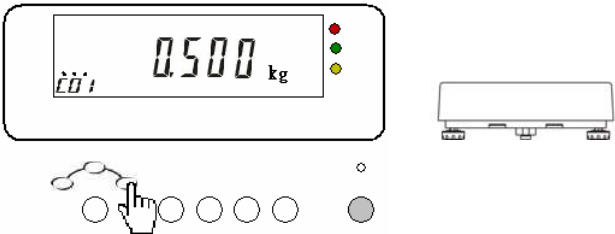
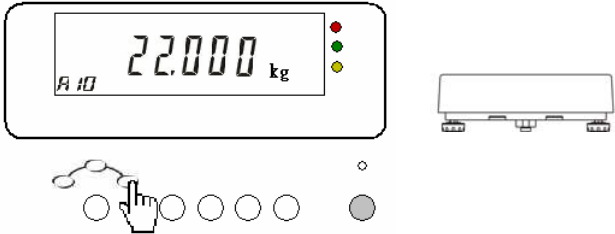
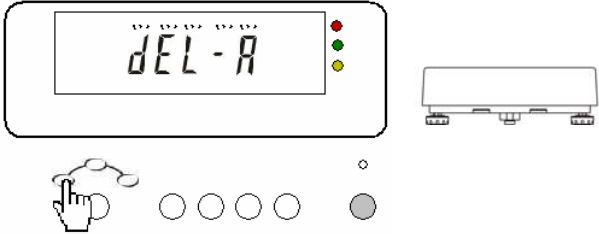
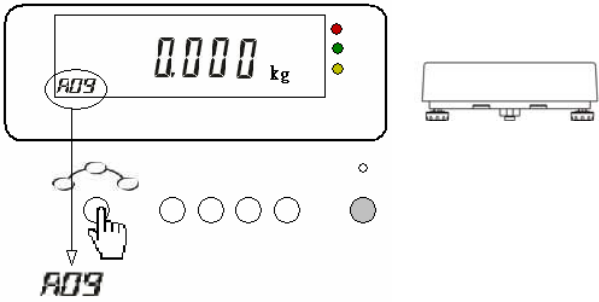
	<p>(8). Press MR EN/DIS key again, it will tell you the weight of the first accumulation. The operation message display will show 01.</p> <p>One can also press UNIT LOV to move to last accumulation.</p>
	<p>(9). To delete accumulations, press MR EN/DIS key to recall the respective accumulation. For example R 1 or 09.</p>
	<p>(10). Press M- S.NO and when the display show DEL-R (meaning to delete all the accumulations) or DEL-09 (to delete the respective accumulation). Press M- S.NO key to confirm delete</p>
	<p>(11). If all the accumulations are deleted, the display will return to normal weighing mode. When there is only one single accumulation that has been deleted, the small indication will blink and need to press ZERO ESC key to return to normal weighing mode.</p>
<p>Remarks <input type="checkbox"/></p> <p>Maximum number of accumulation is 20 units.</p>	

ACCUMULATION MODE SETTING

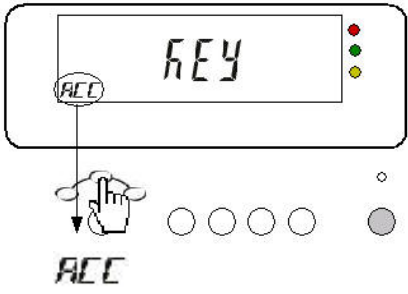
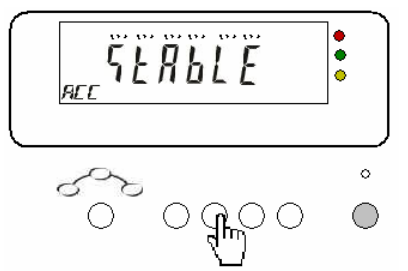
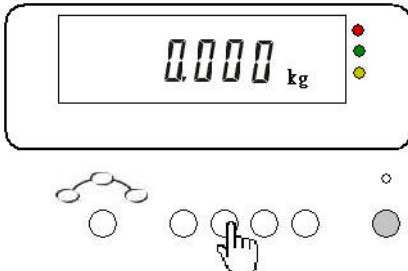
	<p>(1). While the pan is empty press M+ key, display show <i>FEY</i> and the operation message display show <i>ACC</i>.</p>
	<p>(2). Press PRINT HIA or UNIT LOV key to select the accumulation mode. (refer to the below mentioned chart)</p>
	<p>(3). Press M+ key to complete the setting and return to normal weighing mode.</p>







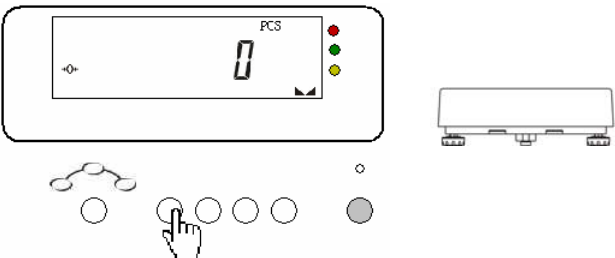

Accumulation mode

FEY Accumulate manually by pressing **M+**

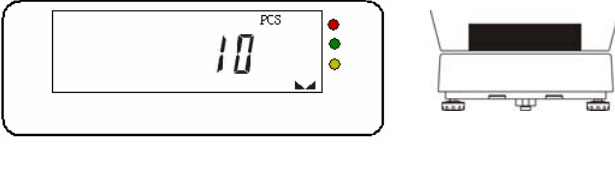
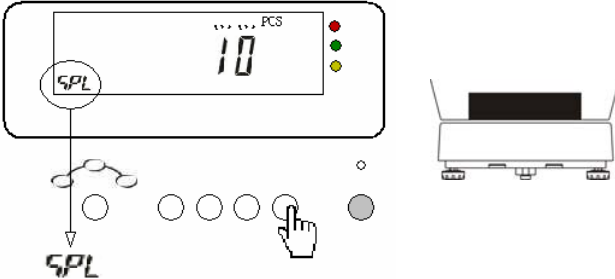

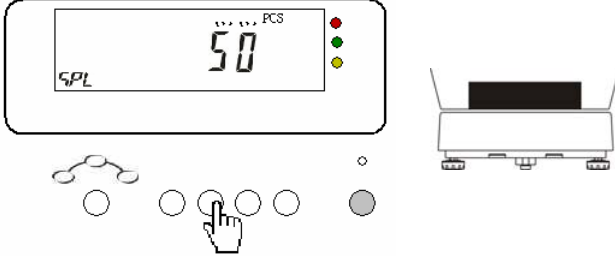

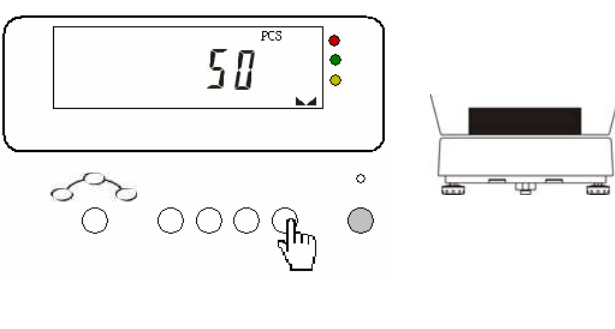

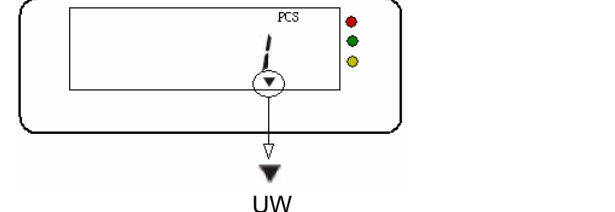

STABLE Accumulate when stable symbol appear

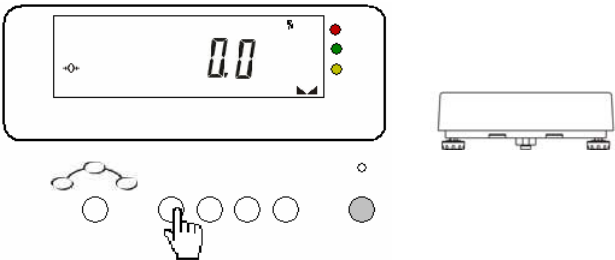
OH Accumulate when weighing is between HI –LO checking limits. (this function is valid even if HI-LO checking function is disabled)

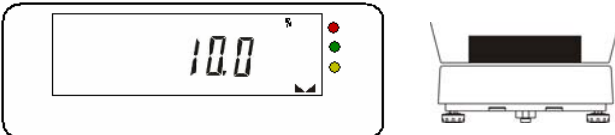
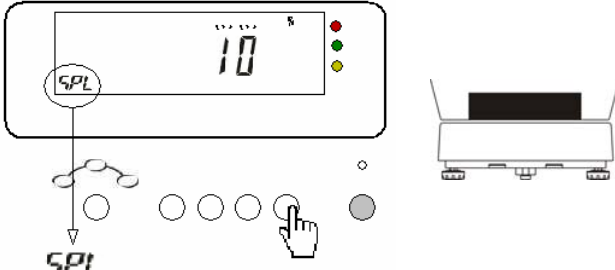

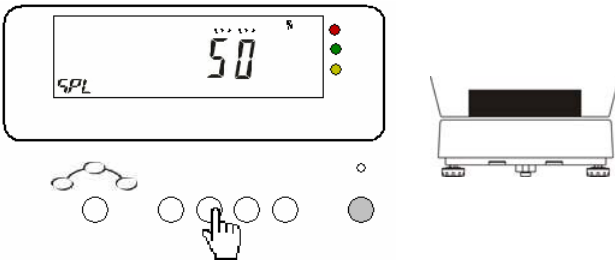

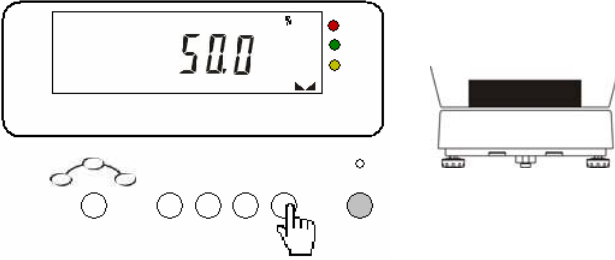

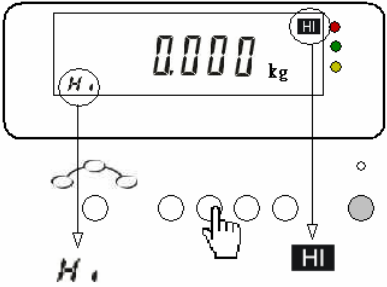

SIMPLE COUNTING

	<p>(6). Press  key to select the PCS as weighing unit.</p>
	<p>(7). Place the sampling quantity on the pan. (You can choose the sampling quantity as 10□25□50□100PCS only!)</p>
	<p>(8). Press  key, display show the number of it as 10PCS (flashing) and the operation message display will show SPL.</p>
	<p>(9). Press  or  key to select the sampling quantity. For example, if you select 50pcs for sampling quantity 50pcs (flashing) will be displayed on the screen.</p>
	<p>(10). Press  key to complete the sampling procedures. Now the scale is ready for simple counting. Put the same objects on the pan for counting.</p>
	<p>Remarks: If the sampling quantity's unit weight for 1pcs is <math>< 0.8 \times \text{division}</math>, indication of insufficient unit weight will appear.</p>

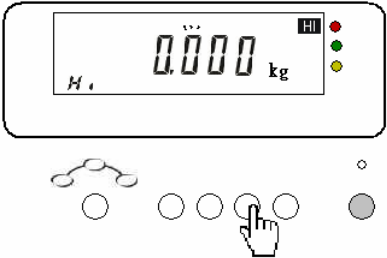
PERCENTAGE %

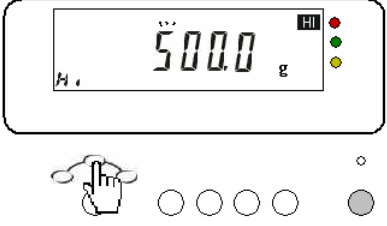
	<p>(1). Press  key to select <input type="checkbox"/> as weighing unit .</p>
	<p>(2). Place the sampling quantity on the pan. (You can choose the sampling quantity as 10 <input type="checkbox"/> 25 <input type="checkbox"/> 50 or 100 %)</p>
	<p>(3). Press  key, display show the number of it as 10 % (flashing) and the operation message display will show SPL indicate now is in sampling mode.</p>
	<p>(4). Press  or  key to select the sampling quantity. For example, if you select 50 % for sampling quantity; 50 % (flashing) will be displayed on the screen.</p>
	<p>(5). Press  key to complete the sampling procedures. Now the scale is ready for simple percentage weighing. Put object on the pan for percentage weighing.</p>

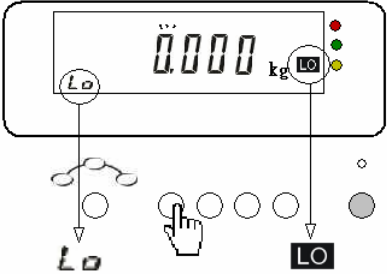
HI / LO Checking for weight



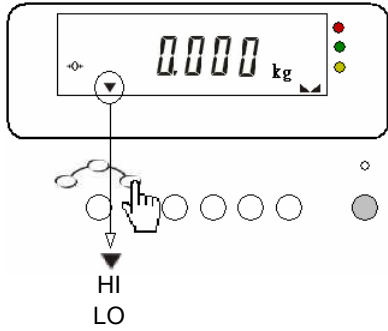
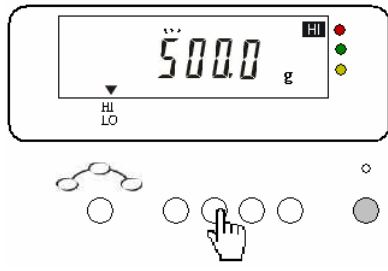
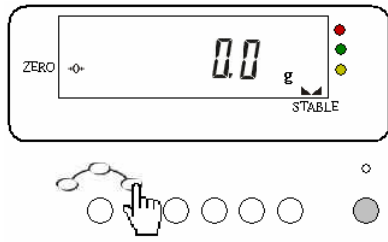



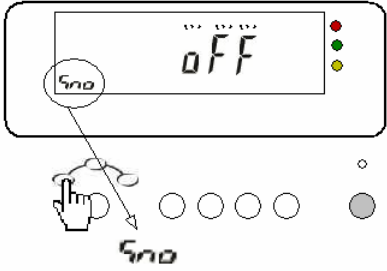
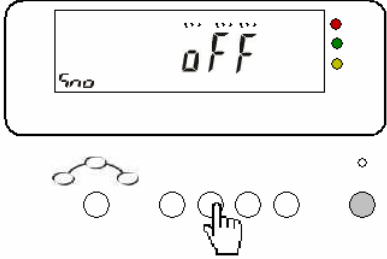
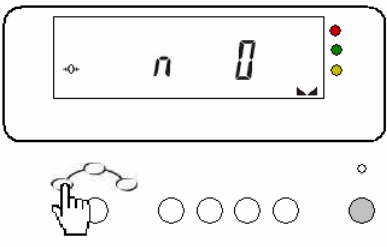

	<p>(1). Press  key, indicator is ready for entering the value of the HI limit, the HI indication on the right will appear and the operation message display will appear <i>Hi</i></p> <p>Remark : If the parameter 3(P3) is not set as <i>no-USE</i>, press  for 3 seconds to set this function.</p>
	<p>(2). Press  key to move the cursor to the digit you want to change.</p>
	<p>(3). Press  or  key to enter the number.</p> <p>(4). Repeat <input type="text" value="2"/><input type="text" value="0"/><input type="text" value="0"/><input type="text" value="3"/> to complete the setting of HI limit.</p>
	<p>(5). Press  key, indicator is ready for entering the value of the LO limit, the LO indication on the right will appear and the operation message display on the left will show <i>Lo</i>.</p> <p>(6). Repeat (2), (3), (4) to complete the setting of LO limit.</p>

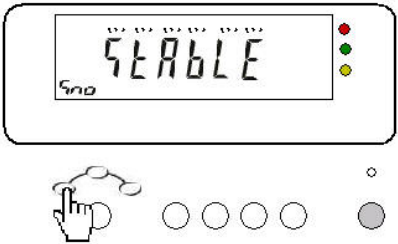
	<p style="text-align: center;">MR</p> <p>(7). Press EN/DIS key to enable the checking function and the scale returns to the normal weighing mode. The arrow pointing to HI, LO will appear and the HI, LO function is ready for operation.</p>
	<p>(8). To cancel the function of HI-LO checking, press PRINT key when the indication of HI-LO indication signs is on the LCD.</p>
	<p style="text-align: center;">MR</p> <p>(9). Followed by pressing EN/DIS key . HI□LO indication signs will disappear and this function is disabled.</p> <p>Remarks: LO limits must be < HI limits</p>

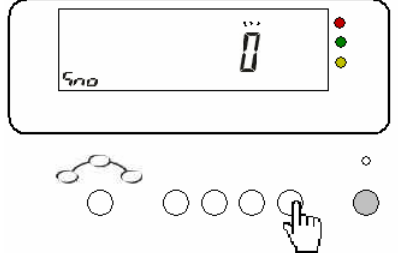
SERIAL NUMBER

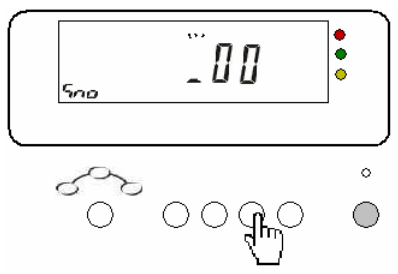
	<p>(1). Press M- S.NO key display will show <i>OFF</i> (flashing) and operation message display will show <i>S.NO</i>.</p>
	<p>(2). Press PRINT or UNIT, to select the desired serial number mode. Please refer to below diagram.</p>
	<p>(3). After select, press M- S.NO key to return to weighing mode, display will now show <i>n</i> <i>▮</i> for serial number, except if the setting is in <i>OFF</i> mode.</p>
<p>Mode of serial number</p> <ul style="list-style-type: none"> <i>OFF</i> : No action. <i>STABLE</i> : The serial number plus 1 (+1) when the stable sign appear. <i>HI</i> : Serial number plus 1 (+1) when the weights is in between HI – LO checking limits this function is valid even if the HI-LO checking function is disabled. <i>STOP</i> : Pause! No adding of serial number but display will still show the last serial number when there is nothing on the pan. 	

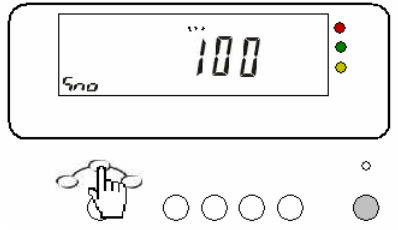
STARTING SERIAL NUMBER SETTING

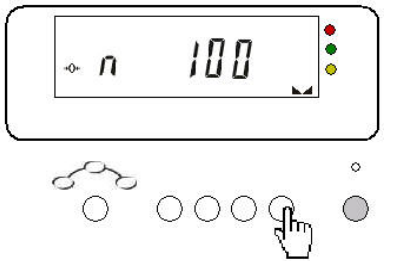

	<p>(1). Under normal weighing mode</p> <p>M-</p> <p>press s.NO key, display will show the current mode of series number, for example :</p> 
	<p>(2). Press GROSS/NET key, display will show</p> 
	<p>(3). Press TARE key to move the cursor to selected digit for change. Example □ Serial number starting from 100, then move the cursor to</p> 
	<p>(4). Press M+ or M- key to key in the number. Example □ 100 is the starting serial number</p> 
	<p>(5). Press GROSS/NET key to save the changes and return to normal weighing mode.</p> <p>Now the starting serial number is 100</p> <p>Remarks: Max. serial number is 99999</p>

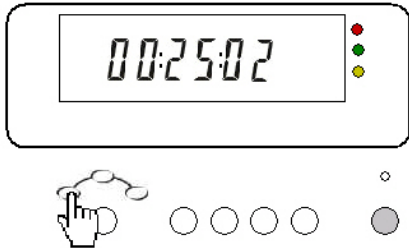
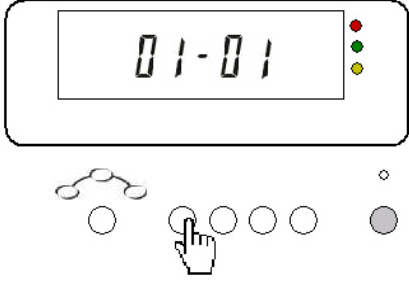
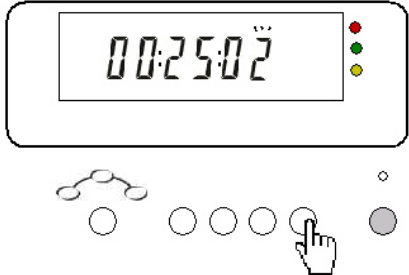
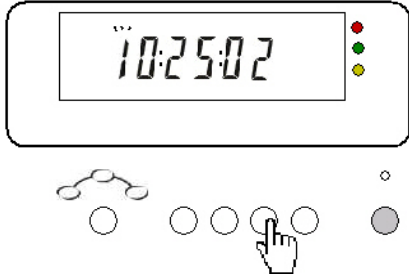
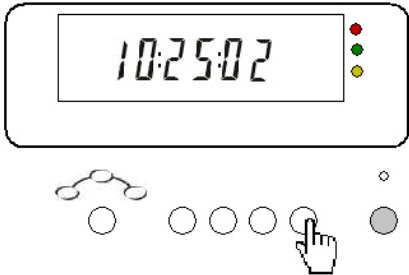
TIME SETTING

	<p>(1). Under normal weighing mode</p> <p>press M- <small>S.NO</small> key for 3 seconds and display will show the time.</p>
	<p>(2). Press PRINT <small>HIA</small> or UNIT <small>LOY</small> to switch to DATE / MONTH or YEAR display.</p> <p>Remark : To escape press ZERO <small>ESC</small> or M- <small>S.NO</small></p>
	<p>(3). Press GROSS <small>NET</small> key to enter to time setting mode. Last digit is flashing.</p>
	<p>(4). Press TARE key to move the cursor and press M+ or M- <small>S.NO</small> key to change the digits.</p> <p>Remark : Now can also press PRINT <small>HIA</small> or UNIT <small>LOY</small> and switch to setting of DATE / MONTH or YEAR.</p>
	<p>(5). Press GROSS <small>NET</small> key to complete the setting and display the current TIME.</p> <p>(6). Press ZERO <small>ESC</small> to return to normal weighing mode.</p> <p>Remarks: After switching off the indicator, the date/time will be</p>



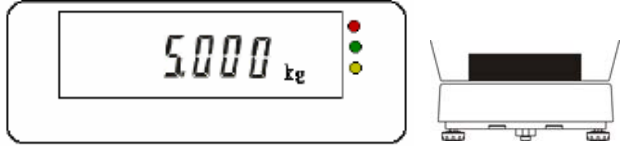
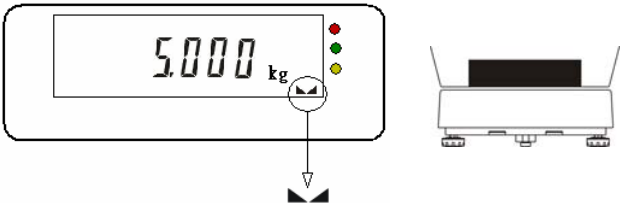
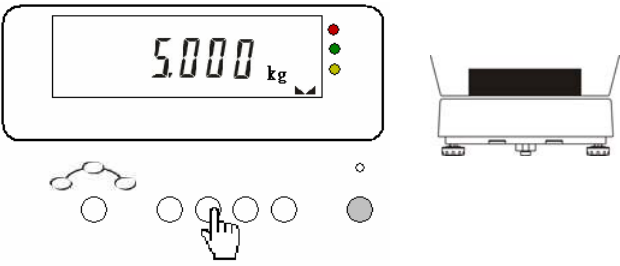



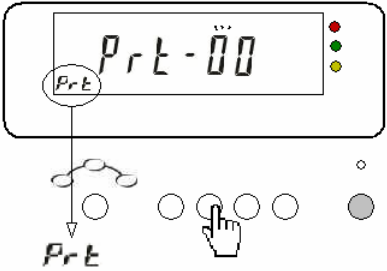

	<p>erased unless if this indicator is equipped with RTC + Rs232.</p>
--	--

PRINT

	<p>(1). Place the object on the pan.</p>
	<p>(2). Wait for the stable symbol.</p>
	<p>(3). Press  to print.</p> <p>Remarks: This function is workable only with the purchased of RS-232 interface and compatible printer.(P3 should also be set to compatible printer)</p>



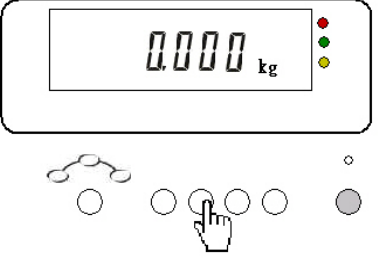



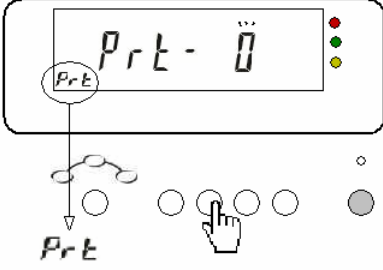

PRINT FORMAT SETTING

This function is applicable only when the Parameter P3 - Printer Type is set to normal , SH-24 , BP-443D or EZ-2P.

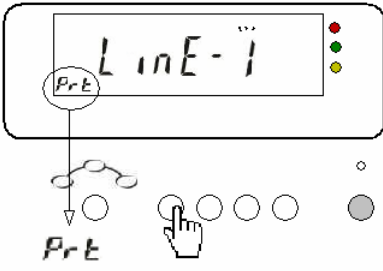
	<p>(1). Under normal weighing mode press  key when the pan is empty. Display <i>Prt-00</i>, (flashing) and the operation message display will show <i>Prt</i>.</p> <p>Remark : If P3 was set to <i>no-USE</i>, the scale will then enter to HI limit setting.</p>
	<p>(2). Press  key to move the cursor and use  or  key to key in number. In total there are 100 print format available for choose.</p>
	<p>(3). Press  key to complete the chosen and return to normal weighing mode.</p>
<p>Note:</p> <p>1. There are three options of printers available : SH-24(dot-matrix printer), BP-443D(Label printer) or EZ-2P(Label printer).</p>	

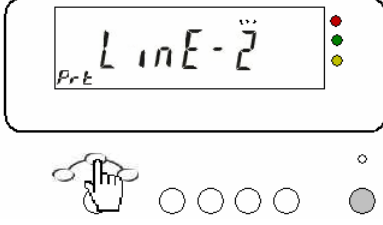

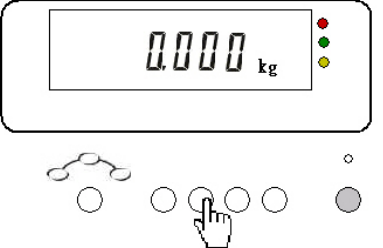



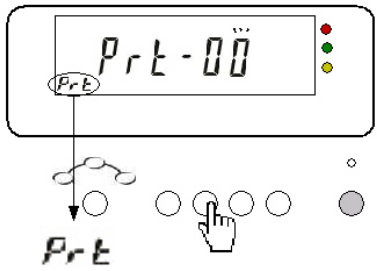

SPACE BETWEEN LINES WHEN PRINTING

Only available for SH24 / normal

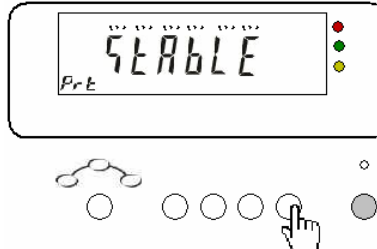
	<p>(1). In parameter for printer(P3) choose the setting to SH-24 / NORMAL.</p>
 <p>The diagram shows a control panel with a display showing 'Prt-0'. A hand is shown pressing the 'Prt' key. Below the display, there are several circular buttons, with the first one labeled 'Prt'.</p>	<p>(2). While the pan is empty press  key and display shows <i>Prt-0</i>. The operation message display will show <i>Prt</i> □</p>
 <p>The diagram shows a control panel with a display showing 'Line-1'. A hand is shown pressing the 'UNIT LOV' key. Below the display, there are several circular buttons, with the first one labeled 'Prt'.</p>	<p>(3). Press  key, display show <i>Line-1</i>. The operation message display will show <i>Prt</i>.</p>
 <p>The diagram shows a control panel with a display showing 'Line-2'. A hand is shown pressing the 'M+' or 'M-' key. Below the display, there are several circular buttons, with the first one labeled 'Prt'.</p>	<p>(4). Press  or  key to set the number of empty lines (space) when printing. {minimum =0, maximum=9}</p>
 <p>The diagram shows a control panel with a display showing '0.000 kg'. A hand is shown pressing the 'PRINT HIA' key. Below the display, there are several circular buttons, with the first one labeled 'Prt'.</p>	<p>(5). Press  key to complete the setting and return to normal weighing mode.</p>

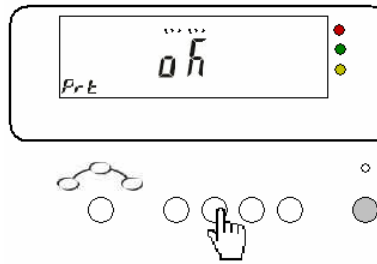
PRINTING MODE SETTING

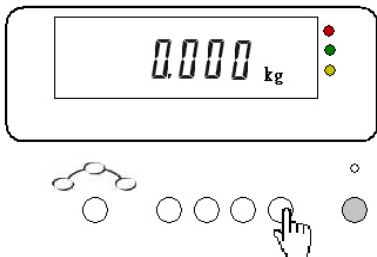
* This function is applicable only when the Parameter P3 - Printer Type is set to normal, SH-24 , BP-443D , or EZ-2P.

	<p>(1). Press  key. Display show <i>Prt-00</i>, operation message display show <i>Prt</i>.</p>
	<p>(2). Press  key. Display will show the printing mode. Example </p>
	<p>(3). Use  or  key to select the printing mode. (refer to the below mentioned chart)</p>
	<p>(4). Press  key to save changes and return to normal weighing mode.</p>

- KEY* : Print manually by pressing PRINT key.
- Cont'n* : Print continuously when connecting to PC or large LED Display.
- STABLE* : Print after stable symbol appear
- ah* : Print when weight is between HI-LO limits (this function is valid even if HI-LO checking function is disabled)

SAMPLES OF BP-443D / EZ-2P PRINTING FORMAT

prt-00

2004/11/25 12:27:58
N.W. **1. 000 kg**
T.W. **0. 500 kg**
G.W. **1. 500 kg**

prt-01

2004/11/25 2:28:11
1. 000 kg
 ABC COMPANY
 0981-123456

prt-02

2004/11/25 12:28:26
1. 000 kg

prt-03

2004/11/25 12:28:26
N.W. **1. 000 kg**
T.W. **0. 500 kg**
kg

prt-04

2004/11/25 12:28:50
1. 000 kg

prt-05

Tw: 0. 500 kg GW: 1. 500 kg
1. 000 kg
 2004/11/25 12:29:04
1 2 3
rate

prt-06

Tw: 0. 500 kg GW: 1. 500 kg
1. 000 kg
2004/11/25 12:29:14

prt-07

Tw: 0. 500 kg GW: 1. 500 kg
1. 000 kg
 2004/11/25 12:29:39

prt-08

2004/11/25 12:29:50
1. 000 kg
0

prt-09

N.W. 1.000 kg
T.W. 0.500 kg
G.W. 1.500 kg

* 10 Print formats are preset in printer by Jadever

- Note: (1) Please contact your supplier/-dealer for additional EZ-2P & BP-443D print formats.
- (2) A memory card has to be installed in EZ-2P.
 (BP-443D memory card is standard)
- (3) The print formats are installed into the printers through PC. Please email your specific requirement to us and we will make the requested print format for you.

SAMPLES OF SH-24 PRINTING FORMATS

When **ALL03** appear under display of accumulation,







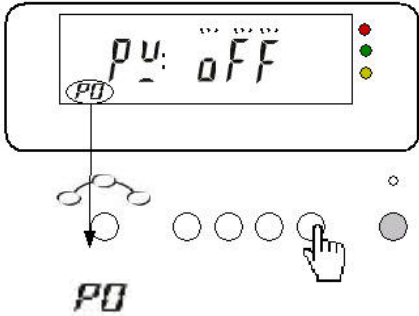

press  key the print-out will like as following.

Prt-00	0.379kg
Prt-01	2002/01/01 00:09:23 0.379kg
Prt-02	#1 0.379kg
Prt-03	2002/01/01 00:09:23 #1 0.379kg
Prt-04	N.W: 0.379 kg T.W: 0.100 kg G.W: 0.479 kg
Prt-05	2002/01/01 00:09:23 N.W: 0.379 kg T.W: 0.100 kg G.W: 0.479 kg
Prt-06	#1 N.W: 0.379 kg T.W: 0.100 kg G.W: 0.479 kg
Prt-07	2002/01/01 00:09:23 #1 N.W: 0.379 kg T.W: 0.100 kg G.W: 0.479 kg

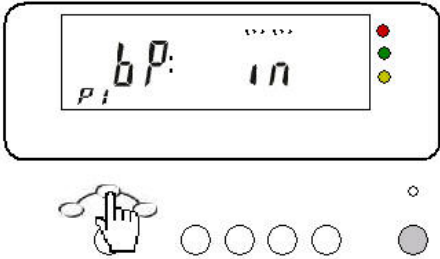

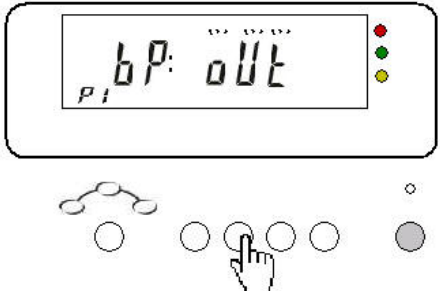
```

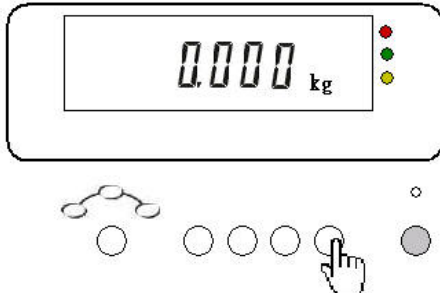
2002/01/01 00:09:23
(1) 0.100 kg
(2) 0.100 kg
(3) 0.100 kg
-----
0.300 kg
    
```

PARAMETER SETTING



	<p>(1). Press  key and turn on the scale or under normal weighing mode, press  key for 3 seconds. Display will show <i>PU: OFF</i> and operation message display show <i>PU</i>.</p>
	<p>(2). Use  or  key to select the parameter <input type="checkbox"/> refer to the chart below <input type="checkbox"/></p>
	<p>(3). Use  or  to change the setting of each parameter</p>
	<p>(4). Press  key to save changes and return to normal weighing mode.</p>

EXPLANATION OF PARAMETERS

No	Function	Display	Detail
PO	Auto Power Off (weights < 20d)	off	Off (No action)
		5	5 minutes
		10	10 minutes
		30	30 minutes
		<input type="checkbox"/> 60	60 minutes
		90	90 minutes
P1	Beeping (The effect of this parameter is to determine when to have beep sounds during HI/OK/LO checking.)	<input type="checkbox"/> in	Scale <input type="checkbox"/> Enable the HI-LO checking functions , beeps when the range is between HI & LO
		out	Scale <input type="checkbox"/> Enable the HI-LO checking functions, beeps when the range is out of HI & LO
		Ein	Option <input type="checkbox"/> Relay with light tower <input type="checkbox"/> beeps when the range is between HI & LO
		Eout	Option <input type="checkbox"/> Relay with light tower <input type="checkbox"/> beeps when the range is out of HI & LO
P2	HOLD (able to hold the displayed weight after load is remove)	<input type="checkbox"/> off	No action of Hold
		on	Able to hold the displayed weight and print at the same time after pressing print key  (when there is loading ). Press key  to clear. *This function will work only when P3-Printer Type is set as NORMAL or SH-24.
P3	Printer type Setting of this parameter determines the data format for the connected printer type	<input type="checkbox"/> no-use	No connection to any printer
		normal	N/A
		SH-24	Normal dot-matrix printer
		BP-443	Label Printer
		EP-2P	Label Printer

P4	RS-232 Baud Rate Setting of this parameter determines RS-232 data transmission rate.		2400	
			4800	
		*	9600	
			19200	
P5	RS-232Data Format Setting of this parameter determines the RS-232 transmission data format.	*	n81	
			o81	
			E81	
			n71	
			o71	
			E71	
P6	Backlight		off	No Backlight
			on	Backlight is on always
		*	5sUE	Off automatically 5 seconds after stable weighing
			Auto	Auto (backlight is actuated when weight loading is over 20d)

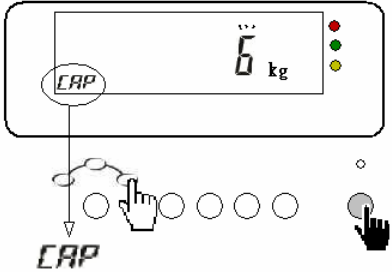
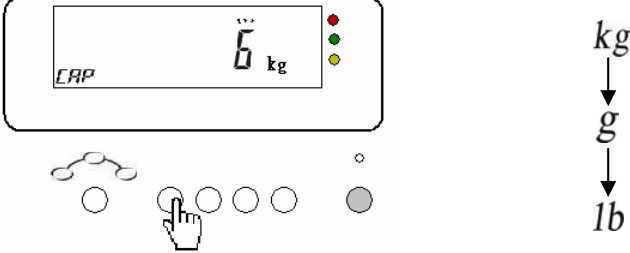
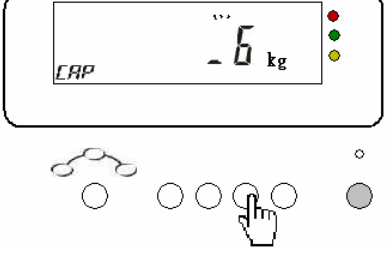
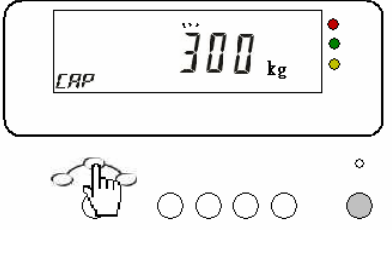
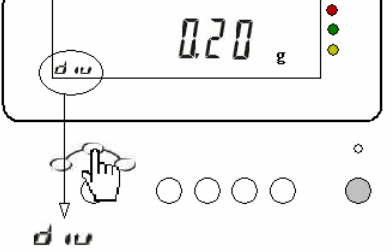
CAPACITY / RESOLUTION SETTING

	<p>(1). Press MR key and turn on the scale. Display will show capacity of the scale (flashing), operation message display will show CAP</p>
	<p>(2). If to use low capacity such as 600g or use lb as unit, press UNIT key to select the weighing unit as g or lb.</p>
	<p>(3). Use TARE key to move the cursor to the digit which needs to be change.</p>
	<p>(4). Press M+ or M- key to enter the desired capacity and complete the setting</p>
	<p>(5). Press MR key and enter into setting of resolution mode. Display will show the resolution (flashing) and operation message display will indicate d u symbol.</p>
	<p>(6). Repeat steps (3), (4) to complete setting of resolution.</p>

**MR**

(7). Press **EN/DIS** key and display will show the internal self checking value and stop. This means that setting of capacity/resolution is completed.

Example

Turn off the scale and turn on again.

Note

Maximum capacity to be set for this indicator is 400000kg.

Minimum division to be set for this indicator is 0.01g.

Whenever the capacity / resolution is set or changed, be sure to re-calibrate according to calibration procedure on service manual.

DIVISION CONFIGURATION CHART

Kg	g	lb
Max 5000kg	Max 5000g	Max 500lb
2000kg	2000g	200lb
1000kg	1000g	100lb
500kg	500g	50lb
200kg	200g	20lb
100kg	100g	10lb
50kg	50g	5lb
20kg	20g	2lb
10kg	10g	1lb
5kg	5g	0.5lb
2kg	2g	0.2lb
1kg	1g	0.1lb
0.5kg	0.5g	0.05lb
0.2kg	0.2g	0.02lb
0.1kg	0.1g	0.01lb
0.05kg	0.05g	0.005lb
0.02kg	0.02g	0.002lb
0.01kg	0.01g	0.001lb

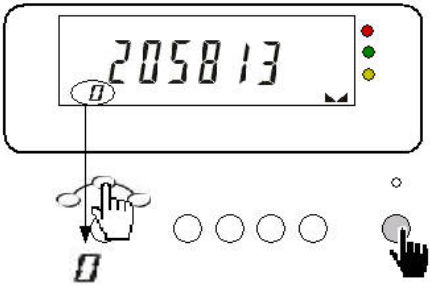
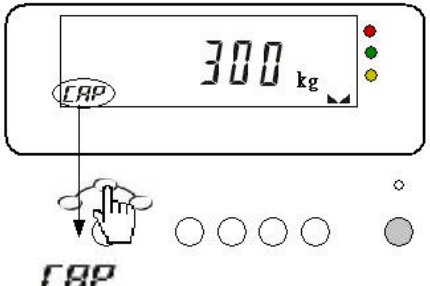
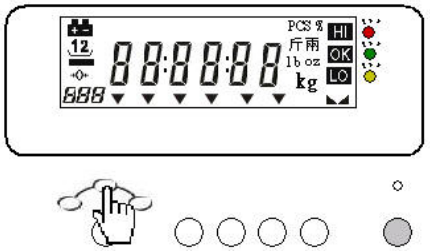
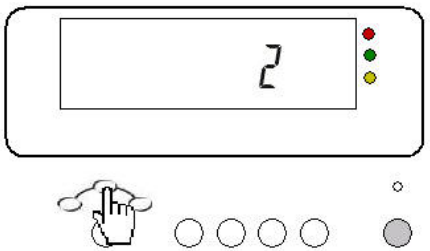
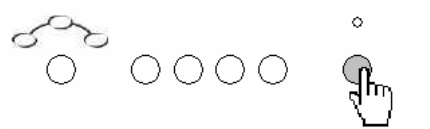

TESTING MODE









	<p>(1). Press M+ key and turn on the scale. Display will show the internal count value and operation message display show 0.</p>
	<p>(2). Press M+ key, display will show the setting of capacity, the operation message display will show CAP.</p>
	<p>(3). Press M+ key and all segments in display are appearing. This is to check if the display is in good condition.</p>
	<p>(4). Press M+ key, display show 2, this is to check the key function condition.</p>
	<p>(5). After testing completed press ON/OFF key to switch off.</p>

* Relative position:

1	:	Memory Cancel	5	:	Unit
2	:	Accumulation	6	:	Print
3	:	Zero / Esc	7	:	Tare
4	:	Memory recall	8	:	Gross / Net

ERROR MESSAGES

Error Message	Reasons / Possible Caused	Solutions
E0 <i>no EE</i>	The CPU unable to read the EEPROM	Contact the manufacturer or nearest agent
E1 <i>CAL-d</i>	Unable to read the 3 points calibration range	Refer to "service manual" for calibration procedures
E2 <i>PH</i>	<u>Zero Point is too high</u>	(1) Make sure the pan is empty when turn on the scale or perform the 3 points calibration. (2) Check the connections of wires
E3 <i>PLo</i>	Zero Point is too Low	(1) Make sure the pan is on the scale or perform the 3 points calibration. (2) Check the connections of wires.
E4 <i>UnStR</i>	Unstable zero point	(1) Make sure there is no winds or vibration . (2) Check the connections of wires.
E5 <i>LC-of</i>	(1)Load cell spec. not compatible. (2)calibrating weights mistake	(1) Replace with a compatible load cell. (2) Change with correct calibrating weights.
E6 <i>no LC</i>	Load cell read out always the same	(1)Check if load cell wire are connected correctly.
E7 <i>ou-20</i>	The last accumulation is more than the preset accumulation allowed.	Press  key twice to clear all the accumulation or press  key to return to normal weighing mode.
E8 <i>LC-out</i>	(1). Load cell specification is out of the ADC range (2). Wrong setting for calibration	(1). Choose the compatible load cell. (2). Re-calibrate the scale.
E10 <i>CLh-b</i>	Optional RS-232(RTC) batteries run out	Replace the batteries

<p>E11 <i>d1 FF</i></p>	<p>Unable to accumulate. Two objects are with different units.</p>	<p>Press  twice to clear all accumulation data or press  and return to normal weighing mode.</p>
<p>E12 <i>du-XX</i></p>	<p>Accumulation data exceed preset maximum</p>	<p>Press  twice to clear all accumulation data or press  and return to normal weighing mode.</p>
<p>E13 <i>Lo3Hi</i></p>	<p>Hi / Lo setting incorrect</p>	<p>Press  key and reset Hi / Lo value.</p>
<p>E20 <i>XXXXX</i></p>	<p>External division over Maximum (XXXXX is external resolution)</p>	<p>Press  and reset Capacity / Resolution</p>
<p>E21 <i>duL XX</i></p>	<p>Capacity / Resolution Setting inaccurate.</p>	<p>Press  and redo Calibration (make sure the calibrate weight is correct).</p>
<p>-----</p>	<p>Overload (Maximum display= max .capacity + 9e)</p>	<p>Remove the object from the weighing pan.</p>
	<p>Indicator unable to Switch On when pressing  key</p>	<p>Use a tool to press the RESET key located at the back of the indicator to turn on the scale and clear the problem.</p>

LCD CHARACTERS

0	1	2	3	4	5	6	7	8	9
0	1	2	3	4	5	6	7	8	9

A	B	C	D	E	F	G	H	I	J	K	L
A	b	C	d	E	F	G	H	i	J	K	L

N	O	P	Q	R	S	T	U	V	W	X	Y	Z
n	o	P	q	r	S	t	U	u	v	w	x	z

CONNECTER

Scale To Printer

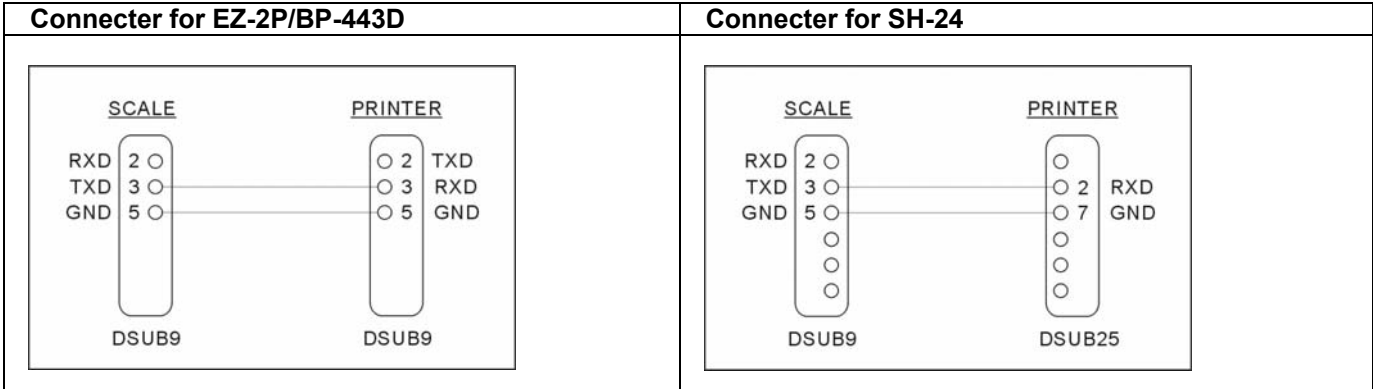

Scale To PC

When you want a scale to transmit data to PC continuously.

- (1) Using a cable as following to connect Scale and PC
- (2) Set printer mode as continue
- (3) Scale data will be sent to PC continuously. (of course, you must have the receiving software on the PC)

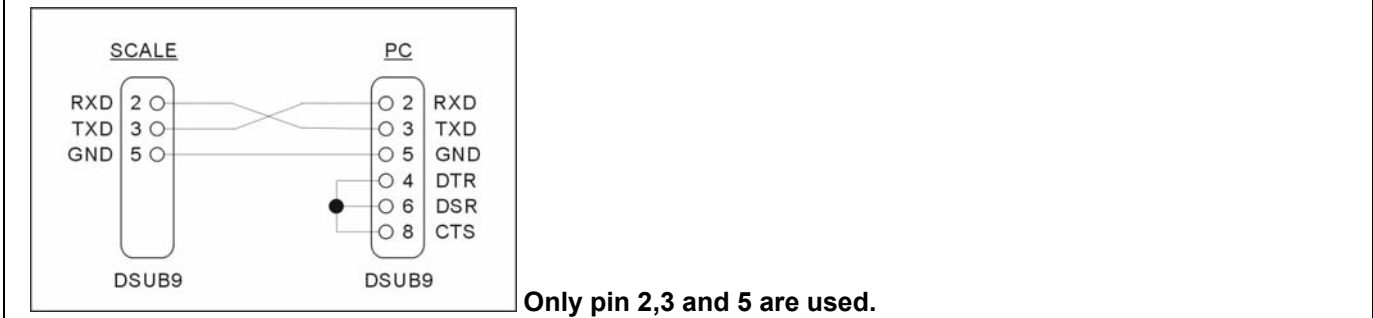

DATA PROTOCOL

- **Output Data when Print Mode set as Continue**

(header1: ST=STABLE US=UNSTABLE)
 (header2: NT=NET GS=GROSS)

For example : ST /NT□+□12.350□kg

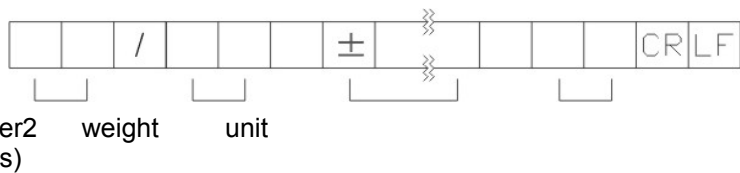

- **Input commands**

“T”=perform TARE function “Z”=perform ZERO function

RELAY MODULE DIAGRAM

■ Relay Output □

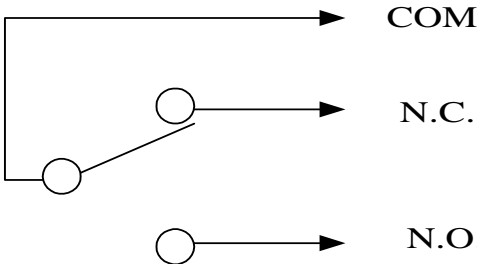
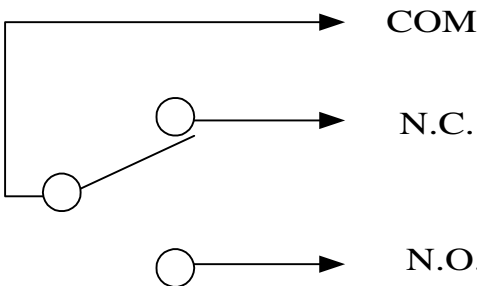
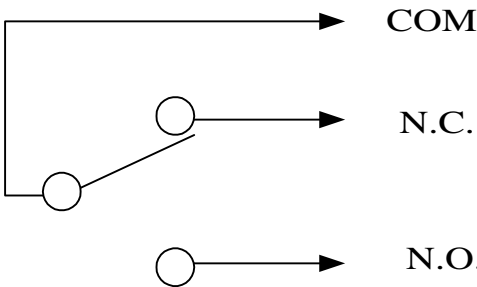
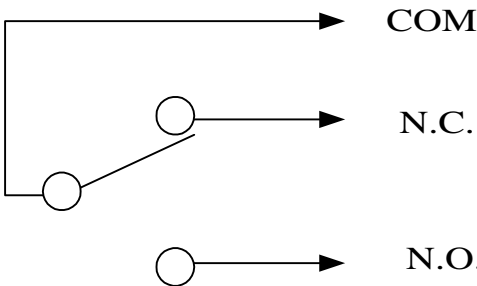
<p>Alarm</p>	
<p>HI</p>	
<p>OK</p>	
<p>LO</p>	

■ Relay Contact Spec

1A/24VDC, 0.5A/125VAC, 0.25A/250VDC

PRODUCT SPECIFICATIONS

1. General

Enclosure	ABS	S/S
Dimensions	230(W) * 150(H) * 90(D) mm	
Display	6digit 30mm(H) & 3digit 10mm(H) LCD(include EL backlight)	
Units	kg or g , lb , □□.□ , □□.□ , pcs , %	
Power	Adaptor 9V/1A RECHARGING BATTERY 6V/3Ah	Adaptor 9V/1A RECHARGING BATTERY 6V/3Ah can be selected
Weight(include Battery)	APPROX. 2.5KG	APPROX. 2.9KG

2. ADC and Loadcell

Model		Basic
ADC	Transform Mode	<input type="checkbox"/> - <input type="checkbox"/>
	Internal Resolution	APPROX. 1,000,000 COUNTS
	External Resolution	MAX. 30,000D(NON-OJML)
	Conversion Speed	10 TIMES/SEC
System Linearity		WITHIN 0.01% OF FS
Loadcell	Excitation	5VDC ± 6% , 120MA(DRIVES UP TO 8 * 350 L.C.)
	Full Scale	-2 ~ 19MV(INCLUDE DEAD LOAD)
	Input Sensitivity	MIN. 0.16W/D(NON-OJML)

ASSEMBLY MANUAL OF JIK INDICATOR AND SUPPORT STAND

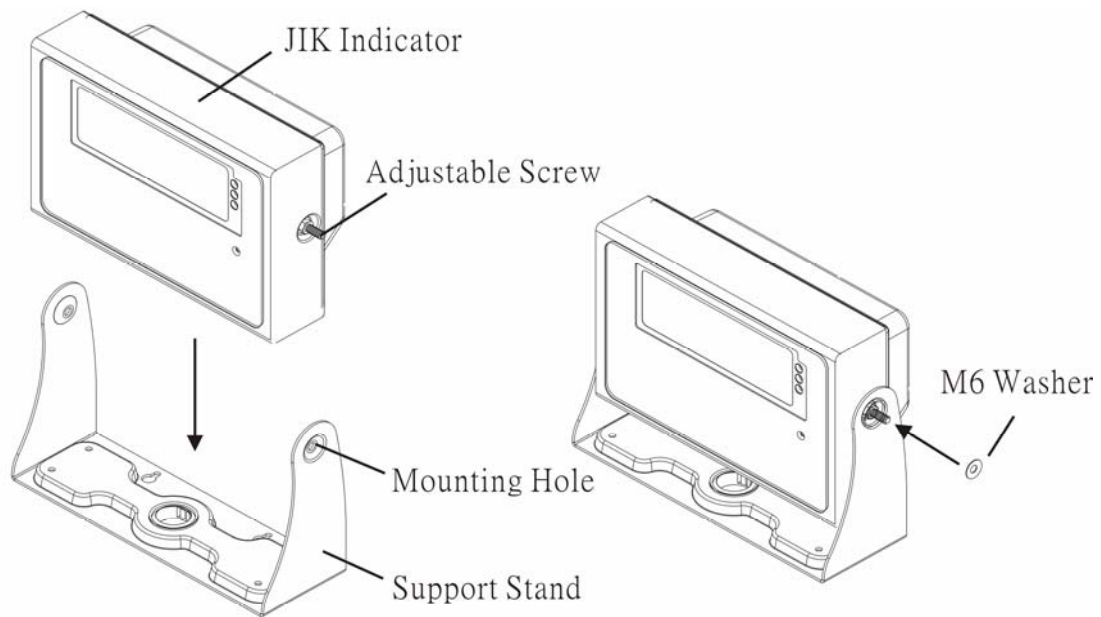

Illustrator I

Illustrator II

1. Using adjustable screw to pass through mounting hole. (illustrator I)
2. Put M6 washer onto adjustable screw. (illustrator II)

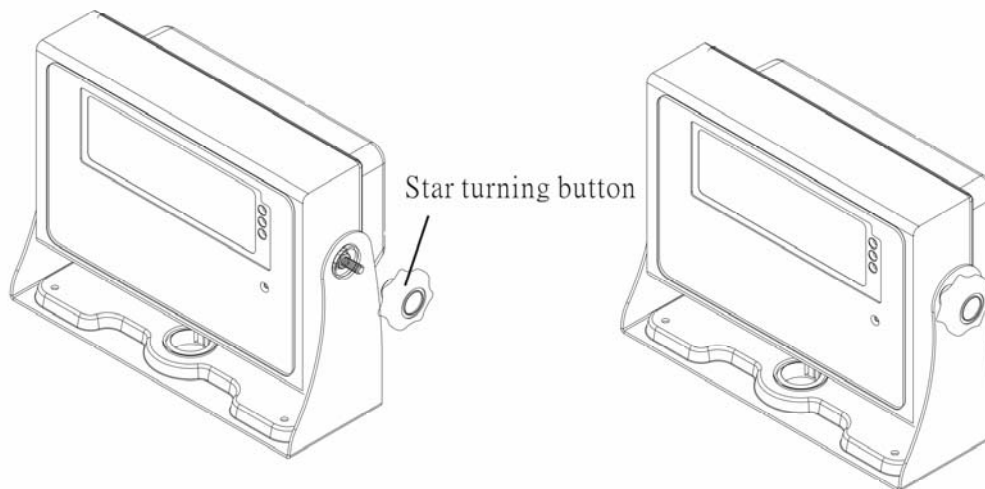

Illustrator III

Illustrator IV

3. Rotating the star turning button into adjustable screw. (illustrator III)
4. Adjust the indicator to the best view, and then rotate it tight via star turning button. (illustrator VI)

FIXING SCREW INSTRUCTION FOR JIK-XXS

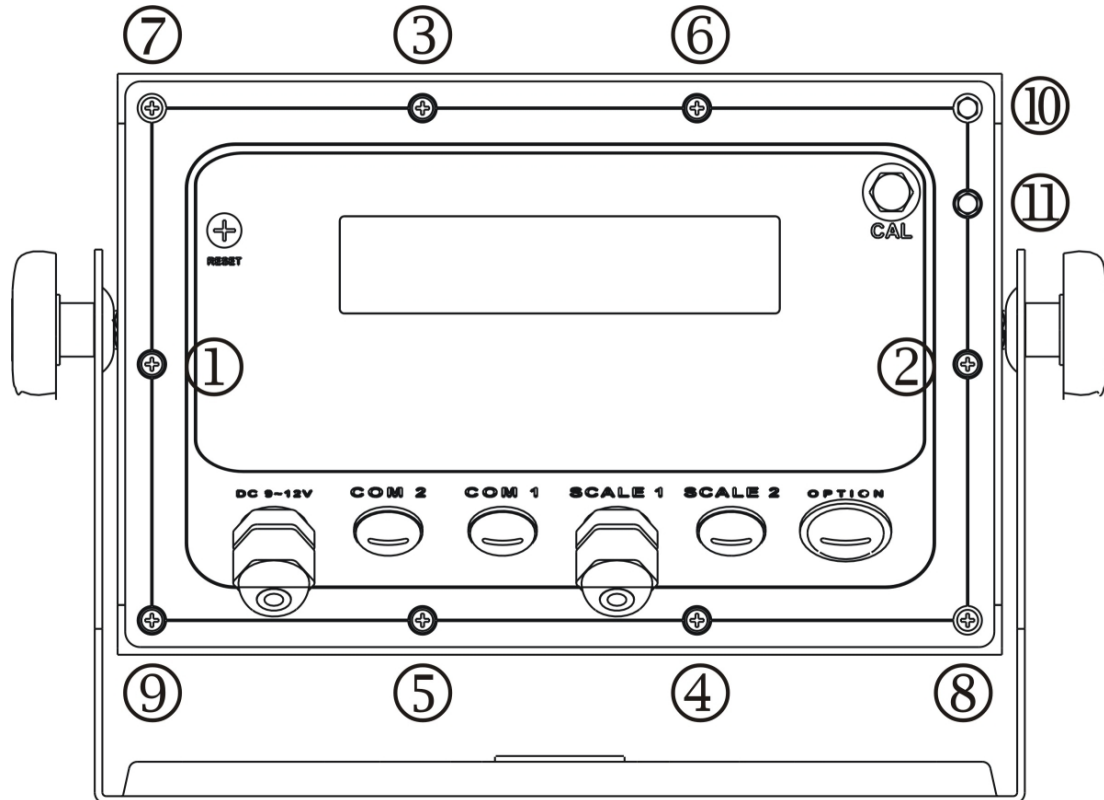





- After connecting load cell and optional devices (RS-232, RELAY), fix all screws attached follow the above numeric sequence.
- If using an electric screwdriver, set the torque range to 5-7 kgf.cm.
- Sealing screws are to be located at sequence 10 and 11.

SINGLE POINT CALIBRATION FOR WEIGHT

Step I (Enter into calibration mode)





Turn on the scale by holding down  key until **CAW** is shown on the lower left screen, i.e. the scale has

Step VI (Single-point Calibration) Note: If to perform three-point calibration, skip this step.

Press  key and the flickering digit will shift to the right; press ,  to adjust the value; input the weight value to be calibrated, and put the correct weight onto the weighing pan, then press  key to save and confirm, once **PASS** is shown, take away the weight on the weighing pan and restart the machine for normal use.

Step VII (Three-point Calibration)

Press  key for 3 seconds until **C-1** is shown at the lower left corner.

First Point C-1: Press  key and the flickering digit will shift to the right; press ,  key to set values; input the weight value to be calibrated, and put the correct weight onto the weighing pan, press  key to confirm and perform calibration.

Second Point C-2: Put the weight to be calibrated onto the weighing pan, the weight value will be shown automatically on the screen; press  key to confirm and perform calibration.

Third Point C-3: Put the weight to be calibrated onto the weighing pan, the weight value will be shown automatically on the screen; press  key to confirm and perform calibration. Once **PASS** is shown, take away the weight on the weighing pan and restart the machine for normal use.

Recalibration: If any error occurs during calibration, press  key to return to zero point calibration mode and perform calibration according to the calibration procedures.

Note: The weight value in three-point calibration shall comply with $C-1 < C-2 < C-3$.

press  key to save setting and the zero point calibration will be performed automatically.