

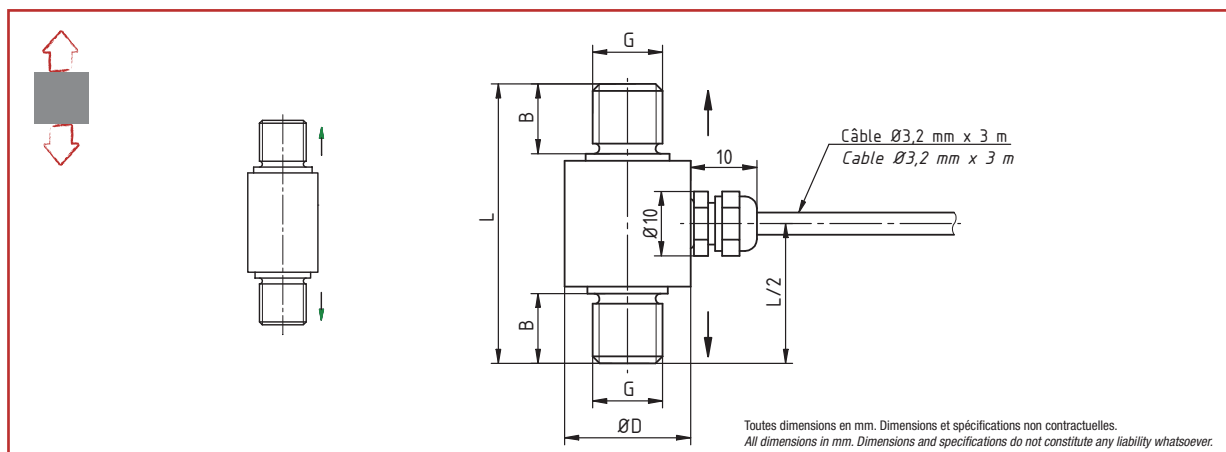

- Construction en acier inoxydable/aluminium
- Degré de protection IP65
- Faible encombrement
- Faible poids
- *Stainless steel construction/aluminum*
- *Protection level IP65*
- *Small dimensions*
- *Small weight*

Câblage - Wiring

+ alim.	+ signal	- signal	- alim.	Cran de calibration	Masse
+ excit.	+ signal	- signal	- excit.	Calibration control	Shield
marron	jaune	blanc	vert	gris	-
<i>brown</i>	<i>yellow</i>	<i>white</i>	<i>green</i>	<i>grey</i>	-



Charge Nominale (C.N.) kN	L	G	D	B
1,2	35	M5 x 0.8	14	8
5	35	M8 x 1.25	14	8
10	40	M10 x 1.5	18	10
20	45	M12 x 1.75	24	12
50	50	M16 x 2	29	15
100	70	M24 x 2	35	20

# K100

0 ... 1 kN à 0 ... 100 kN

## Capteurs de Force - Traction Tension Force Sensor

### Caractéristiques - Specifications

MÉCANIQUES		MECHANICAL	
Charge Nominale (C.N.)	Nominal load (C.N.)	1, 2, 5, 10, 20, 50, 100	kN
Force de travail admissible	Service load	130	% C.N.
Force ultime avant rupture	Ultimate load	> 300	% C.N.
Déflexion sous force nominale	Position feedback at nominal load	< 0.1	mm
PRÉCISIONS		ACCURACY	
Erreur de linéarité en traction	Linearity error for tension	±0.25	% C.N.
Hystérésis	Hysteresis	±0.1	% C.N.
Répétabilité	Repeatability	±0.1	% C.N.
ÉLECTRIQUES		ELECTRICAL	
Impédance du pont	Bridge resistance	350	Ω
Résistance d'isolement	Insulation resistance	> 2 x 10 <sup>9</sup>	Ω
Tension d'alimentation	Supply voltage	2 ... 12 (< 10 kN : 2 ... 6)	Vcc
Tension d'alimentation max.	Max. supply voltage	12 (< 10 kN : 8)	Vcc
Signal de sortie	Sensitivity	0.8 ... 1.2	mV/V
GÉNÉRALES		GENERAL	
Dérive thermique du signal	Temperature coefficient of sensitivity	±0.02	% C.N./°C
Dérive thermique de zéro	Temperature coefficient of zero signal	±0.02	% C.N./°C
Plage de température compensée	Nominal temperature range compensated	0 ... +60	°C
Plage de température opérationnelle	Service temperature range	-10 ... +70	°C
Degré de protection	Level of protection	IP65	
Matériau	boîtier axe	Material	housing measuring body
		Aluminium - <i>Aluminum</i> Acier Inoxydable - <i>Stainless steel</i>	
Connexion		Connexion	Câble 3 m

### Options - Options

Cran de calibration	Calibration control	100	% C.N.
Plage de température compensée	Nominal temperature range compensated	≥ 20 kN : -30 ... +100	°C
Signal de sortie	Sensitivity	≥ 10 kN : 1.00	mV/V
C.N. spéciales	Special ranges		

### Accessoires - Accessories



Rotules de charge EF  
Load adapters EF



CPJ



SDI-718B



GM80 PA

 **scaime**

Siège Social - Headquarter: Technosite Altéa - 294, Rue Georges Charpak - 74100 JUVIGNY - FRANCE  
SCAIME SAS - 294, RUE GEORGES CHARPAK - CS 50501 - 74105 ANNEMASSE CEDEX - FRANCE  
Tél. : +33 (0)4 50 87 78 64 - Fax : +33 (0)4 50 87 78 46 - info@scaime.com - [www.scaime.com](http://www.scaime.com)  
Téléchargez tous nos documents sur notre site internet - Download all our documents on our website