

WKPT

"WKPT - C3": ANALOGUE KIT FOR WEIGHBRIDGES WITH TOUCH-SCREEN INDICATOR



Analogue weighbridges kit made up of 3590ET touch screen weight indicator with AF03 software for weighbridges, 8 stainless steel IP68 "RCPT" analogue load cells, complete with galvanized steel oscillating resting joints and equalisation box with surge arresters.

Touch screen indicator, specific for weighbridge.

Equalisation box with removable terminals and integrated surge arresters.

ANALOGUE load cells in stainless/nickel-plated steel.

TOTAL CAPACITY: **240t** (8 x 30t cells).

OIML R60. C3 precision class.

Load cell height **200mm** (including cups height).

Load cells connection cable length:**18m**.

VETEK AB

HANTVERKSVÄGEN 15 - 76493 - VÄDDÖ - SWEDEN
Tel. +46176-208920, info@vetek.com, www.vetek.com

for advanced industrial
applications

"RCPT" ANALOGUE LOAD CELLS

- C3 precision class.
- Stainless steel interior with nickel-plated steel body; laser solderings.
- Optimized for parallel connection.
- IP68 protection rating.
- Capacity 30000kg.
- 18 m shielded connection cable.
- Fitted with self-aligned articulated joints, self-centering plates and protection washer.
- Minimum load cell verification interval: $V_{min} = E_{Max} / 10.000$
- Maximum number of load cell divisions: $n_{LC} = 3000$ (C3)
- Sensitivity: $2mV/V \pm 0,1\%$
- Temperature effect on full scale: $0,002\% / ^\circ C$
- Temperature effect on zero: $0,002\% / ^\circ C$
- Compensated Temperature Range: $-10^\circ C / +40^\circ C$
- Operating Temperature Range: $-30^\circ C / +70^\circ C$
- Creep error after 30 minutes: $0,02\%$ F.S.
- Excitation voltage from 5 to 15 VDC
- Input Resistance: 700 ± 20 Ohm
- Output Resistance: 703 ± 7 Ohm
- Zero Balance: $\pm 1\%$ F.S.
- Insulation Resistance > 5000 MOhm
- Safe Overload $> 150\%$ F.S.
- Ultimate Overload: 250% F.S.
- 4-wire shielded cable, 18m long, 5mm diameter.

To view the full technical data sheet click [HERE](#).

"3590ET" INDICATOR

- Touch screen, graphic, color display.
- ABS waterproof IP65 case.
- Integrated alibi memory for CE-M approved communication with printer and PC.
- 3 serial ports, 2 RS232 and 1 RS485 for connection to printer, repeater and PC.
- 2 inputs and 4 outputs.
- "AF03" application software suitable for vehicles weighing and weighbridge management, with input/output products check.
- "AF03GT" application software for vehicles weighing and weighbridge management, with input/output products check.

To view the full technical data sheet click [HERE](#).

DETAIL 1



DETAIL 2



DETAIL 3



DETAIL 4

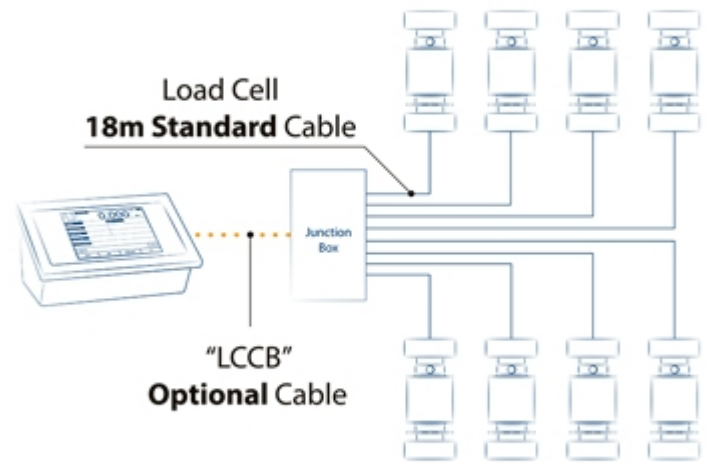



www.diniargeo.com

“YOUR WORLDWIDE PARTNER FOR WEIGHING,”

DINI ARGEO
FRANCE sarl
France

DINI ARGEO
GMBH
Germany

DINI ARGEO
UK Ltd
United Kingdom

DINI ARGEO WEIGHING
INSTRUMENTS Ltd
China

DINI ARGEO
OCEANIA
Australia



COMPANY HEADQUARTERS

Via Della Fisica, 20
41042 Spezzano di Fiorano - Modena - Italy
Tel. +39.0536 843418

VETEK AB

HANTVERKSVÄGEN 15 - 76493 - VÄDDÖ - SWEDEN

Tel. +46176-208920, info@vetek.com, www.vetek.com

SALES AND TECHNICAL ASSISTANCE SERVICE