



More information on the website
radwag.com/en/info,w1,255

C315.6.F1.M Load Cell Platform Scale



The drawings, photos and graphics used are for illustrative purposes only.

Functions

 Plus/Minus Control

 Percent Weighing

 Totalizing

 Parts counting

 Internal battery

 Peak hold

 Newton unit measurement

 GLP Procedures

 Animal weighing

 ALIBI Memory

Datasheet

Metrological parameters	
Maximum capacity [Max]	6 kg
Minimum load	40 g
Readability [d]	2 g
Verification unit [e]	2 g
Tare range	-6 kg
Max readability for non-verified scale	0.2 g
OIML Class	III

Physical parameters	
Display	LCD (backlit)
Protection class	IP 65 construction, IP 43 indicator
Weighing pan dimensions	300×300 mm
Packaging dimensions	570×390×170 mm
Net weight	5 kg
Gross weight	5.5 kg
Communication interface	
RS232 Interface	1× standard, 1× option
Electrical parameters	
Power supply	100 – 240 V AC 50/60 Hz and battery
Power consumption max.	5 W
Operation time on batteries	max 8h
Environmental conditions	
Operating temperature	-10 ÷ +40 °C
Storage temperature	-10 ÷ +50 °C
Relative humidity	10% ÷ 85% RH no condensation
Indicator	C315
Weighing pan material	stainless steel AISI304
Construction	
Construction	mild steel St3S



Extra payment for verification



Accessories

Antivibration Tables

- SAL/STONE/H Stainless Steel Antivibration Table [WX-001-0079]
- SAL/STONE/C Antivibration Table [WX-001-0078]

Power Adapters

- ZR-04/1 Powerbank [WX-015-0329]
- ZR-03/1 Powerbank [WX-015-0319]

RS 232 cables (scale - printer)

- PT0287 Cable [WX-013-0226]

Cigarette lighter receptacle power supply cables

- K0047 Car lighter 12V cable [WX-013-0034]

Displays

- WD-4/8 Additional Display [WX-004-0226]

Displays

- WWG-2/7 Large-Size Display [WX-004-0227]

RS 232 – Ethernet Converter

- KR-04-1 Converter [WX-004-0080]

AP2-1 Current Loop Unit

- AP2-1 Current Loop Unit (Plastic Housing) [WX-016-0011]

RS 232, RS 485 cables

- P0108 Cable [WX-013-0003]
- PT0443 Cable [WX-013-0229]
- P0108.5 Cable [WX-013-0161]

RS 232 – USB Converter

- Moxa UPort 1110 Converter [WX-015-0278]

RS 232 cables (scale - printer)

- P0151 Cable [WX-013-0002]

RS 232 – RS 485 Converter

- KR-01 Converter [WX-004-0021]

Receipt Printer

- RTP-RU80 Radwag Thermal Receipt Printer (RS232 + USB) [WX-007-0119]

Stands, wall mounting kits and mounting brackets

- Stand for measuring indicator PUE C315 - mild steel version [WX-004-0273]

Software

- RAD Key [WX-010-0005]
- R-Panel [WX-010-0187]
- Scale Editor 2.1 [WX-010-0173]
- LabVIEW "Radwag Balances & Scale" Driver [WX-010-0105]
- R-Lab [WX-010-0080]

Device dimensions

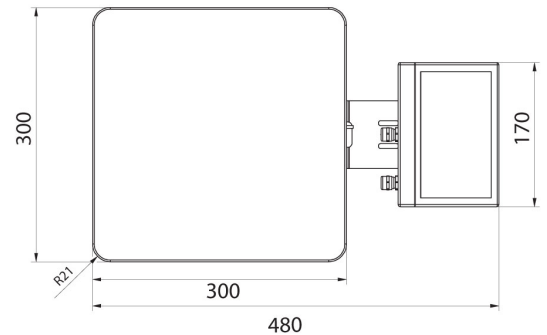
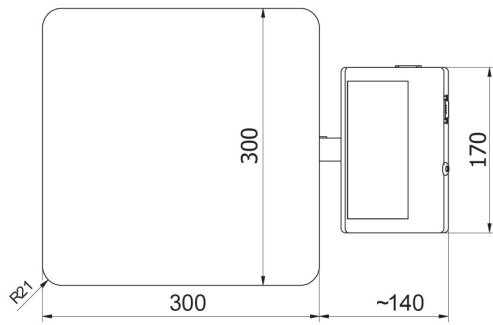
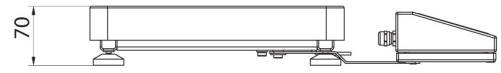
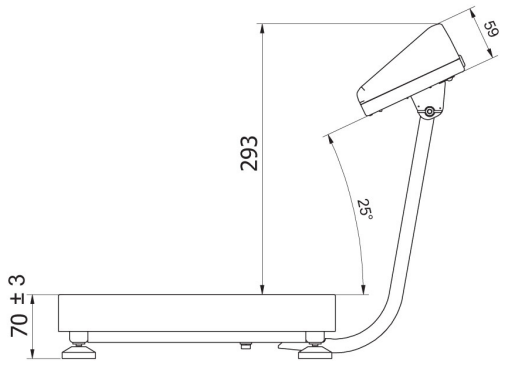

C315.F1.M

C315.F1.R

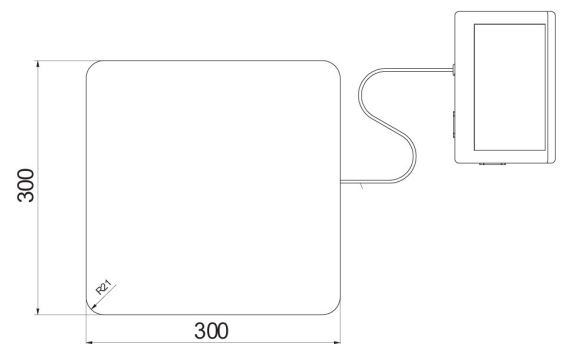
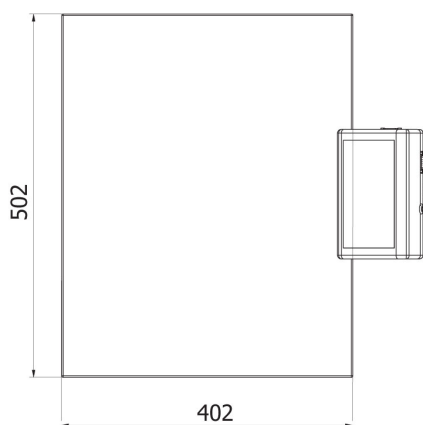
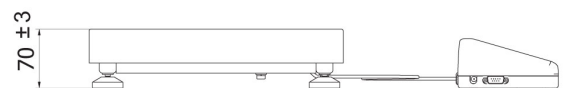
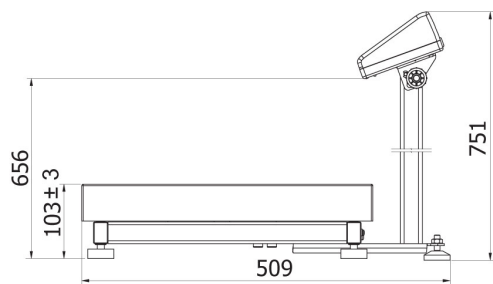

C315.C2.M

C315.C2.K