

AP-12

USER MANUAL

IMMU-1111-12-11-23-EN



RADWAG WAGI ELEKTRONICZNE
ZAAWANSOWANE TECHNOLOGIE WAGOWE

Congratulations and thank you for selecting RADWAG product.

You have purchased a device that has been designed and manufactured to give you years of service.

Please read this user manual carefully, this shall guarantee reliable operation.

NOVEMBER 2023

CONTENTS

1. GENERAL INFORMATION.....	8
1.1. Dimensions	8
1.2. Connectors	9
1.3. Intended Use	10
1.4. Precautions	11
1.5. Warranty Conditions	11
1.6. Supervision Over Metrological Parameters	12
1.7. User Manual Significance.....	12
1.8. Operator Training	12
2. TRANSPORT AND STORAGE.....	13
2.1. Delivery Check.....	13
2.2. Packaging.....	13
3. UNPACKING AND INSTALLATION.....	13
3.1. Workstation	13
3.2. UNPACKING.....	13
3.3. Standard Delivery Components	14
3.4. Unpacking and Start-Up	14
3.4. Maintenance Activities.....	16
3.6. Connecting the Balance to the Mains	18
3.7. Temperature Stabilization Time.....	19
3.8. Connecting Peripheral Equipment	19
4. START-UP	20
5. PROGRAM STRUCTURE	21
6. WEIGHING RESULT WINDOW	22
7. LOG IN	23
8. OPERATING THE MENU	24
8.1. Operation Panel	24
8.2. Voice Commands.....	25
8.3. Return to Weighing.....	26
9. ADJUSTMENT	26
9.1. Internal Adjustment	26
9.2. External Adjustment	26
9.3. Adjustment Test.....	27
9.4. Automatic Adjustment	27
9.5. Automatic Adjustment Time.....	28
9.6. Report Printout	28
9.7. GLP Project.....	28

9.8. Adjustment History	29
10. ADMINISTRATOR PANEL	30
10.1. Password Settings	30
10.2. Operator Accounts Settings	31
10.3. Permissions Management	32
10.4. Remote access password.....	33
11. PROFILES.....	33
11.1. Creating a Profile	34
11.2. Profile Structure	35
11.2.1. Settings	36
11.2.2. Working Modes	36
11.2.3. Readout	37
11.2.4. Units.....	38
12. WORKING MODES – General Information	40
12.1. Running Working Mode	40
12.2. Working Mode Parameters.....	41
12.3. Quick Access Buttons, Proximity Sensors.....	42
12.3.1. Proximity Sensors	43
12.4. Information	44
12.5. Printouts	45
12.6. Profiles	47
13. WEIGHING	48
13.1. Weighing Unit Selection	48
13.2. Good Weighing Practice.....	48
13.3. Levelling	50
13.4. Balance Zeroing	51
13.5. Balance Taring	51
13.6. Additional Parameters for a Weighing Process	52
13.7. Ambient Conditions - Vibrations	55
14. PIPETTE CALIBRATION	60
14.1. Adding Order	63
14.2. Mode Related Settings	63
14.3. Pipettes Calibration – Quick Access Buttons.....	68
14.4. Adding a Pipette to Pipettes Database.....	68
14.5. Printing Reports from the Balance	69
14.6. Pipette Calibration Using the Robot.....	70
14.7. Pipette calibration with use of the automatic system.....	71
14.8. Performed Pipette Calibrations Report.....	76
15. DATABASES.....	77

15.1. Database Operations	77
15.2. PERATORS.....	78
15.3. Customers.....	84
15.4. Pipettes	84
15.5. Pipette calibration order database	85
15.6. Warehouses.....	86
15.7. Printouts / Labels	86
15.8. Universal Variables	89
15.8. Databases Management	89
15.8.1. Delete Databases	89
16. REPORTS.....	91
16.1. Reports Operations.....	91
16.2. Weighings	92
16.3. Pipette calibration order results.....	93
16.4. Ambient Conditions	93
16.5. Reports Management.....	94
16.5.1. Export Weighing Database to a File	94
16.5.2. Delete Weighings and Reports.....	96
17. COMMUNICATION	97
17.1. RS232 Ports Settings	97
17.2. ETHERNET Port Settings.....	97
17.3. Wi-Fi Settings	98
17.3.1. Hot Spot - General Information	99
17.3.2. Hot Spot Activation.....	99
17.4. TCP Settings.....	102
18. PERIPHERALS	103
18.1. Computer.....	103
18.1.1. Computer address	104
18.1.2. Permanent transmission.....	104
18.1.3. Interval.....	105
18.1.4. Weighing printout template	105
18.1.5. Cooperation with E2R System	105
18.2. Printer	106
18.3. Barcode Scanner	109
18.3.1. Barcode Scanner Port	109
18.3.2. Prefix/Suffix.....	110
18.3.3. Field Selection	110

18.3.4. Test.....	111
18.4. Ambient Conditions Module	112
19. MISCELLANEOUS PARAMETERS.....	112
19.1. Interface Language.....	112
19.2. Date and Time	112
19.3. Extension Module	114
19.4. Sound.....	115
19.5. Visual printout cofirmation.....	115
19.6. Sleep Mode.....	115
19.7. Display Brightness.....	115
19.8. Vibration Detection	116
19.9. Level Control	116
19.10. Decimal Point	117
19.11. Proximity Sensors Sensitivity	117
19.12. Autotest.....	117
19.13. Start-Up Logo.....	122
19.14. Export of System Events	122
19.15. Text-To-Speech Conversion.....	122
20. SCHEDULED TASKS	123
20.1. Adjustment.....	123
20.2. Message.....	124
21. UPDATE.....	126
22. ABOUT (system info)	127
23. COMMUNICATION PROTOCOL	127
23.1. Manual Printout / Automatic Printout	127
24. PERIPHERAL DEVICES.....	129
25. ERROR MESSAGES.....	129
26. ADDITIONAL EQUIPMENT	130
27. ANNEX B - Programmable Buttons List	130

1. GENERAL INFORMATION

1.1. Dimensions

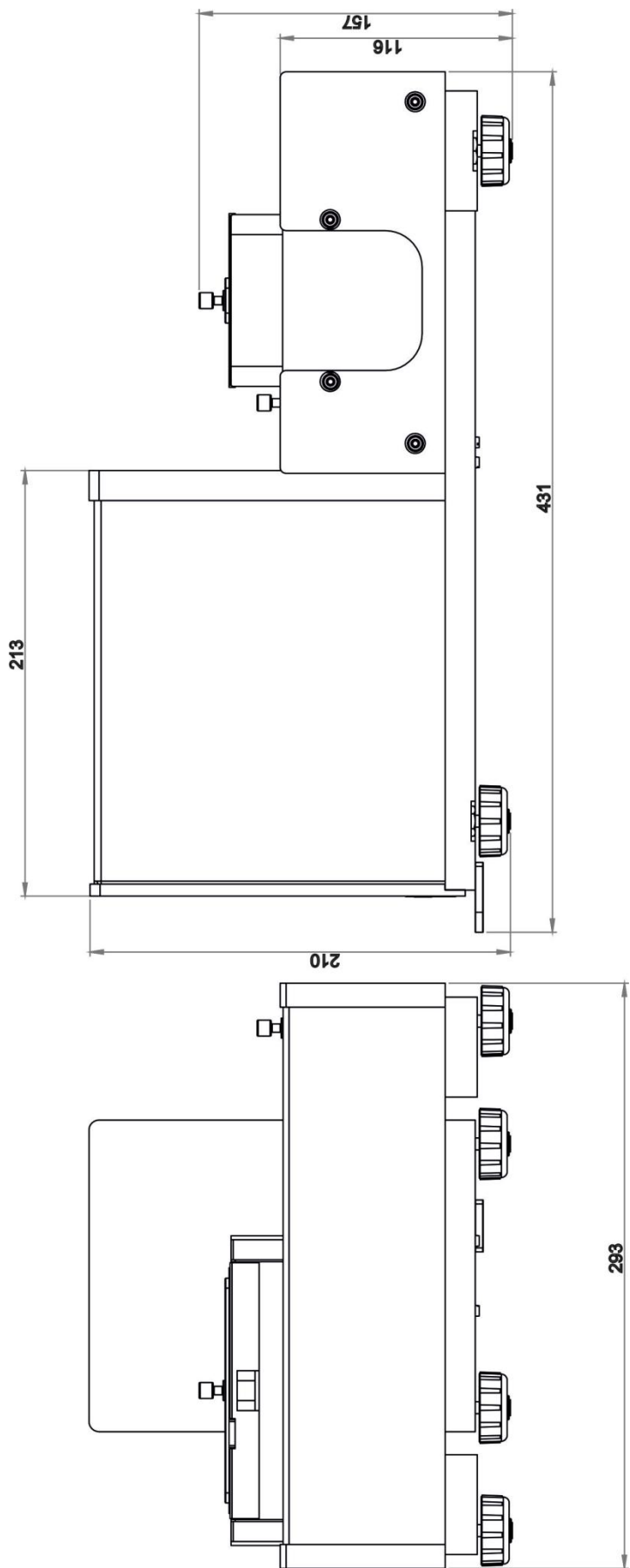

Indicator

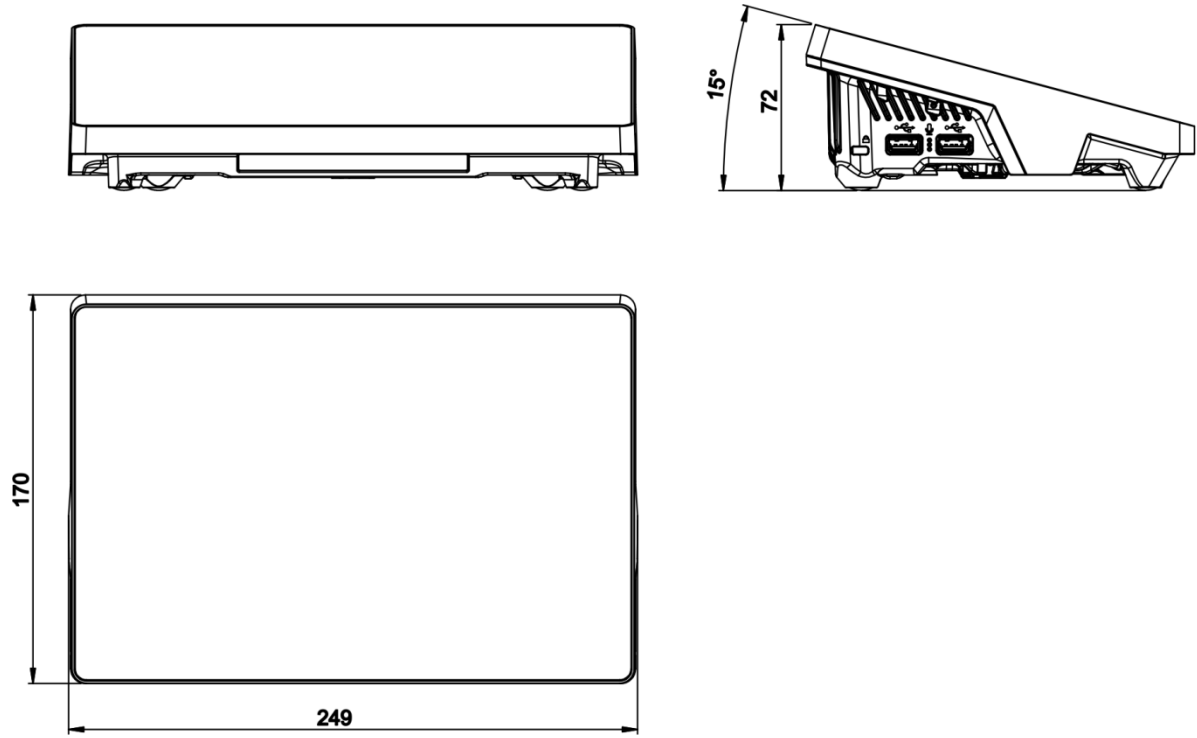

1.2. Connectors

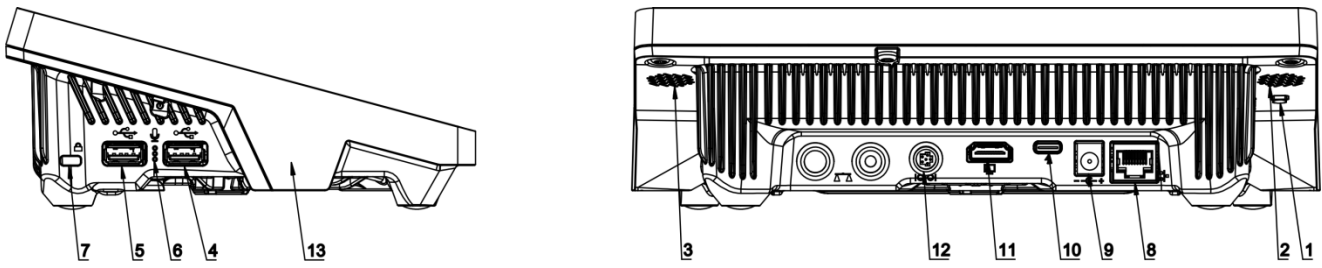

Top view

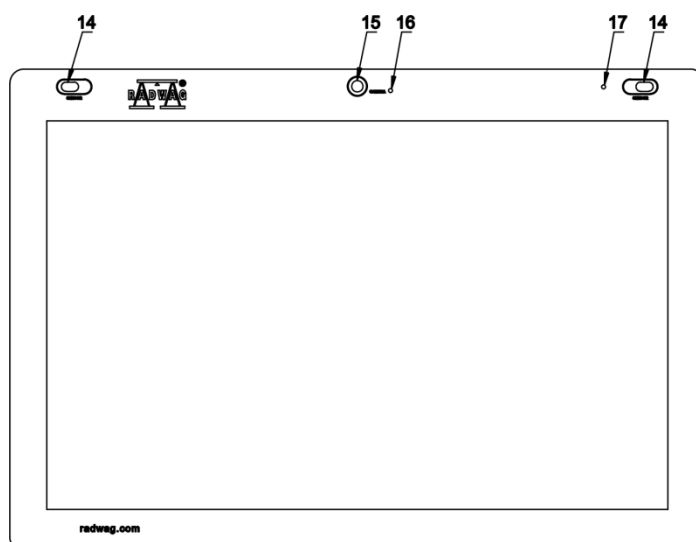

1	Button for hard restarting or switching the balance off/on.	10	Power supply socket – USB type C
2	Left speaker	11	HDMI socket
3	Right speaker	12	Media box socket
4	USB type A	13	RFID sensor
5	USB type A	14	Proximity sensors
6	Microphone	15	Camera
7	Kensington Lock	16	Camera diode
8	Ethernet socket	17	Signalling diode
9	Power supply socket		

1.3. Intended Use

The AP-12.1.5Y is the first automatic device designed to calibrate single- and multi-channel micropipettes with [d] 1 µg, in accordance with ISO 8655 requirements. Pipette calibration can be performed in the volume range from 0.5 µl a maximum of 12 channels of fixed and variable volume pipettes.

The **impressive calibration readability** is the result of the co-called **separation chamber** which stabilizes the measurement path and protects it from excessive air movement. This is a guarantee of **high precision measurements**.

AP-12.1.5Y guarantees the **comfort of work**. The ergonomic design of the device makes it possible to empty weighing vessels, and their overflowing is signalled by Ambient Light. When

calibrating a multichannel pipette, a pump is used to simultaneously remove water from four vessels, greatly reducing the time required for pipette calibration.

After emptying a 12-channel pipette, the AP-12.1.5Y checks all channels in a single cycle. In addition to a **database of pipette calibration reports**, the AP-12.1.5Y includes a database of pipettes that is editable and contains maximum permissible error values according to ISO 8655. The **report database**, in turn, contains measurements and error values calculated for individual points and volumes. The user determines the format and content of the reports.

The AP-12.1.5Y **monitors the ambient conditions** using calibrated sensors: THB S (ambient conditions measurement) and THB W (liquid temperature measurement), in accordance with ISO 8655.

1.4. Precautions

- Prior to the first use, carefully read this user manual. Use the device only as intended.
- Do not operate the touch panel using sharp-edged tools (knife, screwdriver, etc.).
- Load the weighing pan with loads of gross weight which does not exceed the maximum capacity.
- Mind not to leave heavy loads on the weighing pan for longer periods of time.
- In case of damage, immediately unplug the device from the mains.
- The balance to be decommissioned must be decommissioned in accordance with valid legal regulations.
- Do not use the balance in areas endangered with explosion. The balance is not intended to be operated in hazardous areas.

1.5. Warranty Conditions

- A. RADWAG is obliged to repair or exchange all elements that appear to be faulty by production or by construction.
- B. Defining defects of unclear origin and means of their elimination can only be realized with assistance of the manufacturer and user representatives.
- C. RADWAG does not bear any responsibility for damage or loss resulting from unauthorized or inadequate performing of production or service processes.
- D. The warranty does not cover:
 - mechanical damage caused by product exploitation other than intended, damage of thermal and chemical origin, and damage caused by lightning, overvoltage in the power grid or other random event,

- damage caused by product exploitation other than intended, damage, when security seal stickers protecting balance housing against unauthorized access are removed or broken,
- damage caused by liquids and natural wear, or by overloading the measuring mechanism,
- damage caused by inappropriate setting or by electrical system failures,
- inappropriate cleaning habits.

E. Loss of warranty takes place if:

- a repair is carried out outside RADWAG authorized service point,
- service claims intrusion into mechanical or electronic construction by unauthorized people,
- the balance does not feature security stickers.

F. For detailed warranty conditions read the warranty certificate.

1.6. Supervision Over Metrological Parameters

Metrological parameters need to be verified at determined time intervals. The frequency of inspection is determined by the ambient conditions under which the balance is operated, the type of processes performed, and the quality management system used.

1.7. User Manual Significance

Even if you are experienced and have already worked with this type of balance, you are still obliged to read this user manual carefully prior to switching the device on. This user manual provides all the necessary operation-related information. Following the user manual guidelines guarantees correct weighing instrument performance.

1.8. Operator Training

The balance must be operated and supervised only by personnel who have been trained to use this type of weighing instrument.

2. TRANSPORT AND STORAGE

2.1. Delivery Check

Upon delivery, it is necessary to check the package and the device. Make sure that your package bears no signs of damage. Otherwise, contact the manufacturer's representative.

2.2. Packaging

Keep all package elements in case your device is transported in the future. Remember that only the original packaging can be used for shipping purposes. Prior to packing, uncouple any cables and remove any separable components (weighing pan, shields, inserts). The remaining components must be packed into their original packaging. This is to protect them against potential damage during transportation.

3. UNPACKING AND INSTALLATION

3.1. Workstation

- Operate the device in a workroom free of vibrations and shakes, where there are no air drafts nor dust.
- Make sure that the ambient temperature ranges between: +10 °C ÷ +40 °C,
- Make sure that the relative humidity is not higher than 80%.
- Make sure that in the course of balance operation, the room temperature changes slowly and gradually.
- Place the balance either on a robust-design table or on a wall bracket that is both distant from heat sources and unsusceptible to vibrations.
- Should static electricity affect the weighing result, ground the balance's base. The grounding screw is located at the back of the balance base.
- Ultra-microbalances and other devices installed by RADWAG employees in their workplace cannot be relocated. Only authorized RADWAG employees can move the device to another location.

3.2. UNPACKING

Cut the adhesive tape. Take the balance out of the packaging. Open the accessory box and take the balance components out of it.

3.3. Standard Delivery Components

- Balance
- Weighing pan
- Standard weighing pan Phi 25
- Magazine
- Transport cart
- Sensors cover
- Power supply

3.4. Unpacking and Start-Up

1. Take the balance and components out of the box.
2. Place the weighing part on the table and connect the indicator.
3. Assemble the magazine as shown in the diagram below.

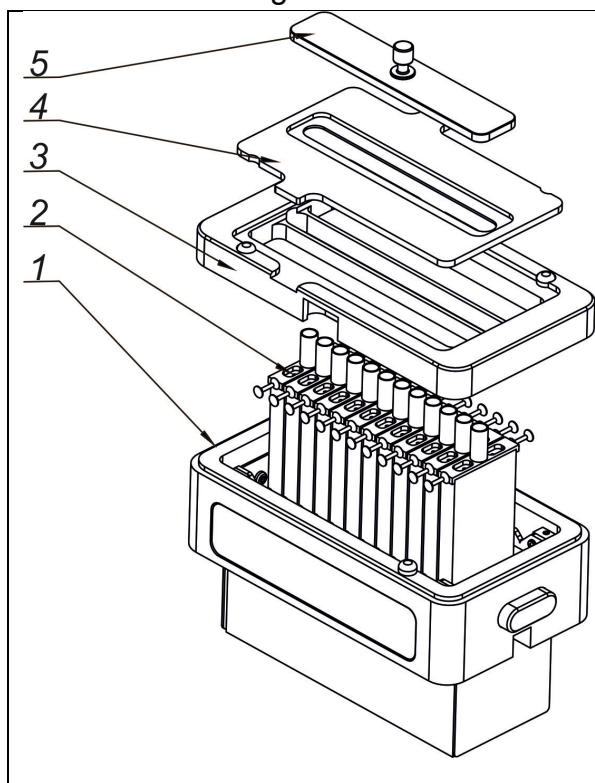

Steps:

1. Place the liquid vials (2), 12 pieces, in the magazine housing (1).
2. Install the evaporation ring (3).
3. Install the cover of the evaporation ring (4).
4. Install the vial lid (5).

4.

5. Insert the weighing pan and other components into the device's body.

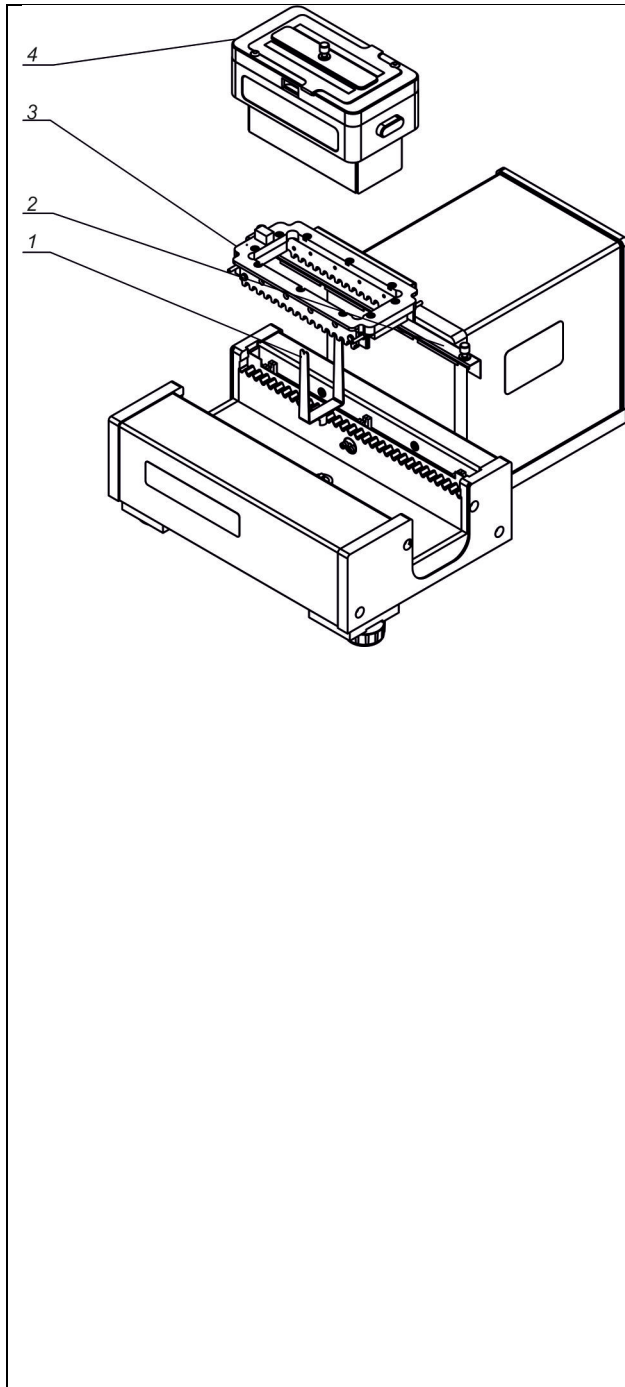

Steps:

1. Remove the sensor cover (2) (pull upwards using the two handles).
2. Install the weighing pan (1). When installing the weighing pan, take care to ensure that it is properly positioned. The flattening on the weighing pan pin must be aligned with the flattening on the weighing pan seat (see figure below).

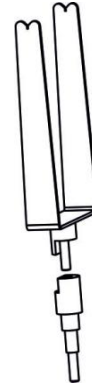

3. Install the transport cart (3) (the transport cart should be in the extreme right or left position).
4. Install the sensor cover.
5. Place the magazine (4) in the rectangular opening of the transport cart (3). Pay special attention to correct positioning of the magazine in relation to the transport cart. A cut-out in the magazine housing must be aligned with the projection of the transport car.

6. Turn on the balance by switching on the power supply. Then follow the standard procedures for the balance's initial startup (levelling, internal adjustment, etc.).
7. The balance is ready for operation.

CAUTION:

Before installing the weighing pan (1), ensure that it is not damaged. Each surface should be adjacent to the positioner (2) as shown below.

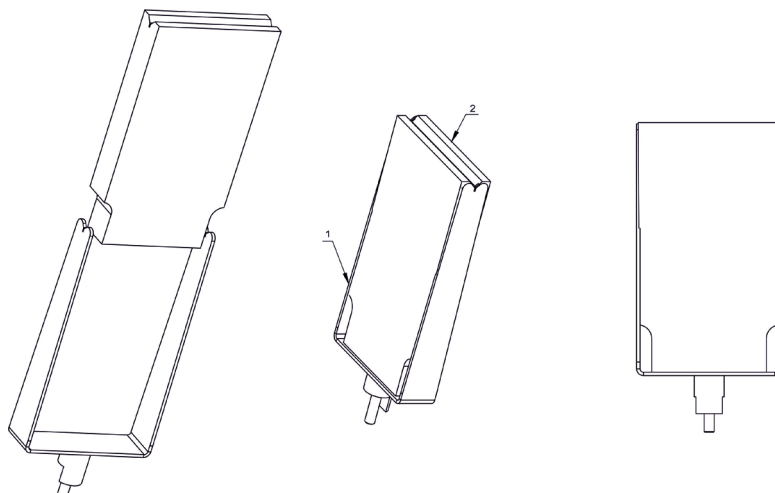

CAUTION:

Be careful while installing the components so as not to cause any damage to the balance mechanism.

CAUTION:

The balance has two sockets for connecting the power supply. One socket is located on the indicator and the other is on the back of the weighing mechanism housing. The balance can be powered from both the indicator and mechanism sides of the balance, but not from both sides at the same time using two power supplies. Such a connection could harm the balance and power supplies.

3.4. Maintenance Activities

CAUTION:

Cleaning the weighing pan while still installed may cause damage of the measuring system.

1. Uninstall the weighing pan and other detachable components (the components differ depending on a balance type – see section: *UNPACKING AND INSTALLATION*). Be careful while installing the components so as not to cause any damage to the balance mechanism. Use tweezers to remove the microbalance weighing pan..
2. Use a handheld vacuum cleaner to remove dust from the weighing chamber (recommended for the microbalance).
3. In order to ease cleaning of some of the weighing instrument components, it is permissible to remove them following the below instruction.

Cleaning anti-draft chamber panes:

Select dissolvent depending on the type of contamination. Never soak the glass panes in alkaline solutions since they interact with glass and may cause damage. Do not use cleansers containing abrasive substances.

For organic dirt use acetone first, next use water or detergent. For other than organic dirt use diluted acid solutions (soluble salts of hydrochloric or nitric acid) or base solutions (ammonium or sodium base).

To remove ACIDS, use a protophilic solvent (sodium carbonate) To remove BASE, use a protogenic solvent (mineral acid of various concentrations).

In the case of heavy contamination, use a brush and detergent. Nevertheless, avoid detergents containing large and hard molecules, which could potentially scratch glass panes.

At the end of the cleaning process, rinse the pane using distilled water.

Use a soft brush with a wooden or plastic handle exclusively to avoid the risk of scratches. Do not use a wire brush.

Rinsing is a necessary cleaning process stage, allowing us to remove remaining soap, detergents, and other cleansers from the panes prior to their reinstallation.

After the preliminary cleaning process stage, rinse the pane using running water first, distilled next.

Avoid drying the panes either using paper towel or forced air circulation since some fibres, grains, or contamination of other types could permeate into the panes, thus causing weighing errors.

We do not recommend using driers when drying measuring glass tools.

It is a common treatment to leave glass components on a rack to dry.

Cleaning powder-coated components:

For the preliminary cleaning process stage, you need running water or a wet sponge with large pores. This will help you to remove loose, heavy dirt.

Do not use cleansers containing abrasive substances.

Next, using a cloth and a cleanser-water solution (soap, dishwashing liquid), gently rub the surface.

Avoid using cleanser without water since it may result in damage to the cleaned surface. Please keep in mind that a large amount of water mixed with cleanser is a must.

Cleaning aluminium components:

While cleaning aluminium components, use products acidic by nature, e.g. spirit vinegar, lemon. Do not use cleansers containing abrasive substances. Avoid using hard brushes; this may cause scratches. It is recommended to use a microfibre cloth.

While polishing the surface, use circular movements. Use a clean, dry cloth to make the surface shine.

Cleaning stainless steel components

When cleaning stainless steel components, the following table should be followed, which lists the types of contamination and ways of removing it.

Fingerprints	Clean with alcohol or dilutant. Rinse with clean water and wipe dry.
Oils, fats, greases	Wash with organic solvents and then clean with warm water with soap or mild detergent. Rinse with clean water and wipe dry.
Temperature stains and discolorations	Wash with a gentle abrasive cleaner, clean lightly according to the direction of the surface structure. Rinse with clean water and wipe dry.
Strong discoloration	Clean lightly according to the direction of the surface structure. Rinse with clean water and wipe dry.
Traces of rust	Moisten with oxalic acid solution and leave for about 15-20 minutes, then wash with warm water with soap or mild detergent. Rinse with clean water and wipe dry.
Paints	Wash with paint solvent and then rinse with warm water with soap or mild detergent. Rinse with clean water and wipe dry.
Scratches on the surface	Gently polish the surface with a non-woven fabric (iron-free) according to the direction of the surface structure. Wash with a gentle abrasive cleaner. Rinse with clean water and wipe dry.

Cleaning ABS components

To clean dry surfaces and avoid smudging, use clean, non-colouring cloths made of cellulose or cotton. You can use a solution of water and detergent (soap, dishwashing detergent, glass cleaner). Gently rub the cleaned surface and let it dry. Repeat the cleaning process if necessary.

In the case of hard to remove contamination, e.g. residues of adhesive, rubber, resin, polyurethane foam, etc., you can use a special cleaning agent based on a mixture of aliphatic hydrocarbons that does not dissolve plastics. We recommend carrying out tests before using the cleanser on all surfaces. Do not use cleansers containing abrasive substances.

3.6. Connecting the Balance to the Mains

The weighing device can be connected to the mains only with a power supply that comes standard with the particular model. The nominal voltage of the power supply (specified on the power supply data plate) has to be compatible with the mains nominal voltage.

Connect the balance to the mains – connect the power adapter to the socket, then connect its connector to the interface located on the back of the balance housing or the indicator housing.

CAUTION: The balance has two sockets for connecting the power supply. One socket is located on the indicator and the other is on the back of the weighing mechanism housing. The balance can be powered from both the indicator and mechanism sides of the balance, but not from both sides at the same time using two power supplies. Such a connection could harm the balance and power supplies.

3.7. Temperature Stabilization Time

Prior to the measuring processes start, it is necessary to wait until the balance reaches thermal stabilisation.

Balances stored at much lower temperatures than the workroom temperature must be subjected to thermal stabilisation before being plugged into the mains. . The thermal stabilisation period takes about 12 hours. During the thermal stabilization, the indications on the screen can change. Temperature changes in the workroom should be minor and gradual.

Thermal stabilization also applies to the ambient conditions monitoring system and balance levelling.

3.8. Connecting Peripheral Equipment

Use only accessories and peripheral equipment recommended by the manufacturer. The balance must be unplugged from the mains before connecting or disconnecting any peripheral equipment (printer, PC, computer keyboard of USB type). Upon connecting the peripherals, plug the balance to the mains.

4. START-UP

- After assembling the device, connect the power supply to the balance.

CAUTION: The balance has two sockets for connecting the power supply. One socket is located on the indicator and the other is on the back of the weighing mechanism housing. The balance can be powered from both the indicator and mechanism sides of the balance, but not from both sides at the same time using two power supplies. Such a connection could harm the balance and power supplies.

- The operating system and the RADWAG program are loaded. This is signalled by the blinking of the LED diodes located at the lower front of the indicator.
- Upon completing start-up, the home screen is displayed automatically.
- The balance runs with no users logged in. In order to start operation, it is necessary to log in (for detailed login procedure, read later sections of this user manual).

Caution: *Prior to the balance start, make sure that there is no load on the weighing pan.*

A hard reset is required if the program crashes during operation. To do so, press and hold the indicator's button for about 5 seconds.

The program restarts and the device reboots.

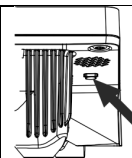

5. PROGRAM STRUCTURE

The program menu is divided into function groups. A function group is a group of interrelated parameters. For a detailed description of each group, read later sections of this service manual.

Function groups:

The main menu is accessed by pressing the  button located in the bottom part of the display.

The menu comprises parameters related to balance settings, functions, and profiles.

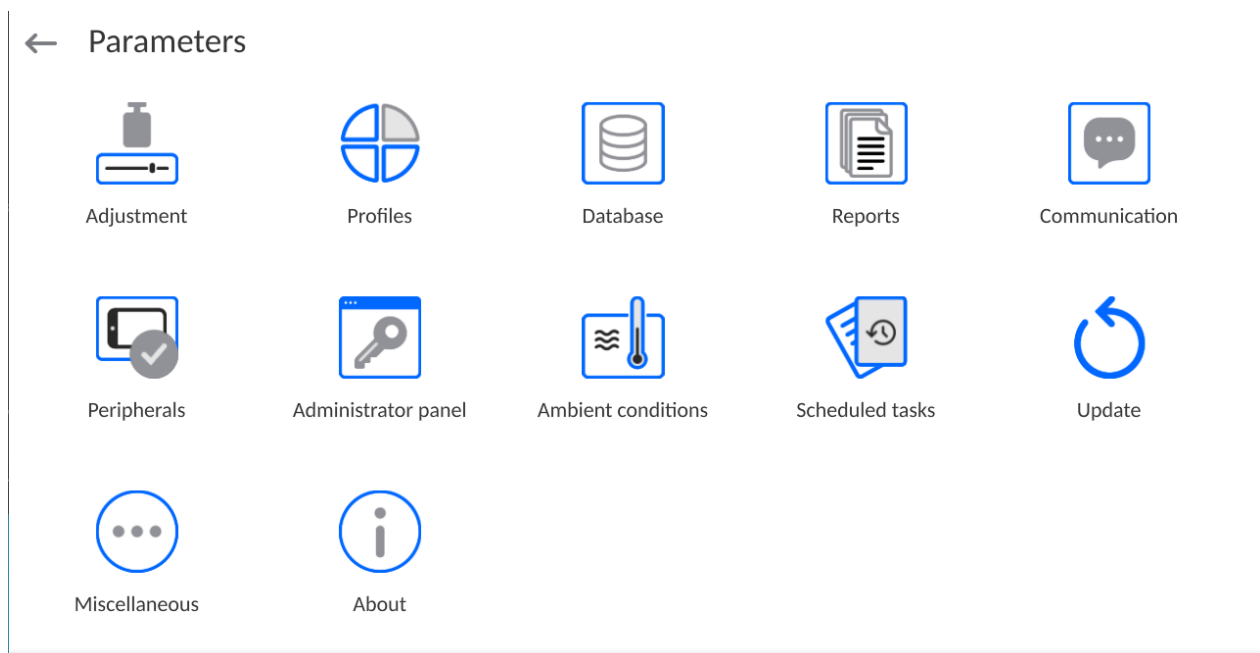

6. WEIGHING RESULT WINDOW



The home screen features 5 sections:

- Top section displaying data on active working mode, logged-in user, date, time, computer connection status.

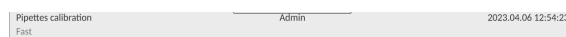

- Section presenting the weighing result and a current level status.

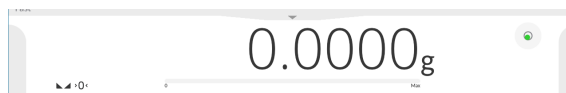

- Section comprising the supplementary information on the currently performed operations (grey background).

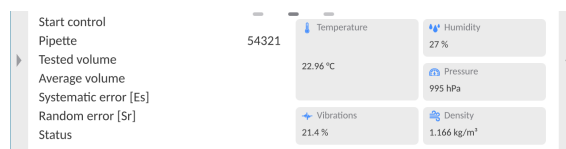

CAUTION:

The data contained in this workspace is freely configurable. For detailed information, read section 12.4 of this user manual.

- Section comprising the on-screen function buttons:



CAUTION:

The operator can define the on-screen function buttons. For detailed information, read section 12.3 of this user manual.

- Section comprising the on-screen function buttons:



7. LOG IN

In order to access operator-related parameters and edit databases, you need to log in as an operator with **<Administrator>** permission level.

To do this, slide down the menu at the top of the display.

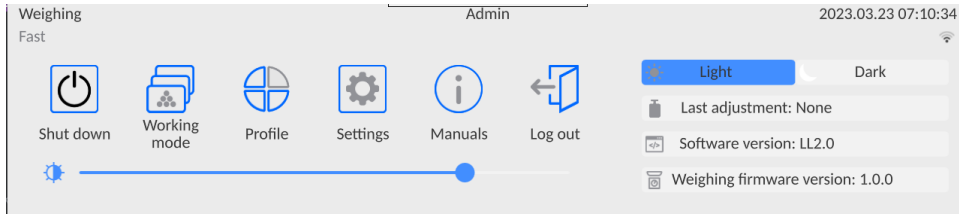

First Log in:

- Slide down the top menu, press the **<Log in>** field, the operators database window is opened featuring the **<Admin>** entry.

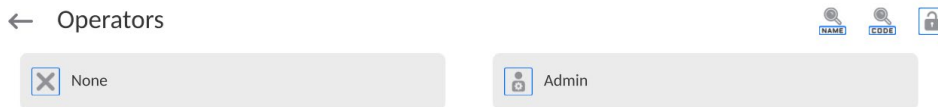

- Press the **<Admin>** entry.
- The home screen is displayed, the **<Not logged in>** sign is replaced by the **<Admin>** sign.

CAUTION: After first logging in, enter

operators and assign appropriate permission levels and individual access passwords to them (for detailed procedure, read sections 10 and 15.2).

While logging in again, select an operator from the list and enter the password. The program initiates operation with the permission level set for the selected operator.

Log out operation:

- Slide down the top menu and press **<Log out>**.
- When the top menu is swiped up to its initial position, the logged-in operator name is replaced with the message **<Not logged in>**.

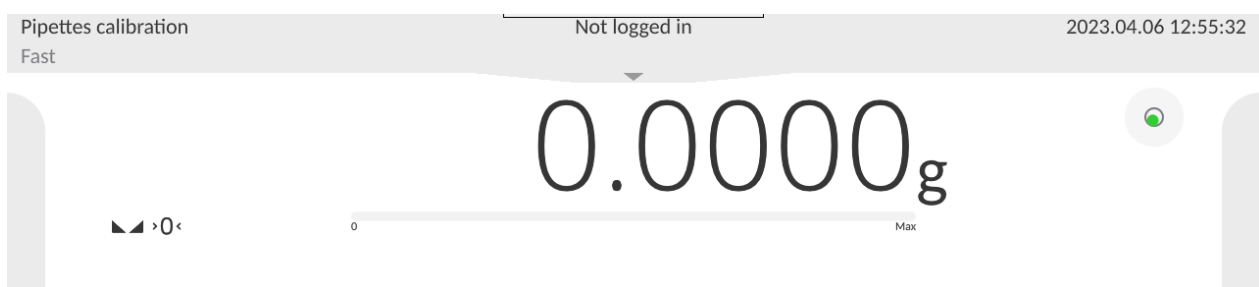

8. OPERATING THE MENU

Operation of the program menu is intuitive. The touch panel makes the software operation easy. Pressing a function button or an area on the display initiates an assigned function or a process.

8.1. Operation Panel



Press to enter the main menu.



Press to confirm modification.



Press to return to the previous view without changing the parameter value.



Press to add a database record.



Press to search for a particular database entry by date.



Press to search for a particular database entry by name.



Press to search for a particular database entry by code.



Press to print database entries.



Press to select printout template variables from the list.



Press to go back.

8.2. Voice Commands

The balance software allows several operations to be performed using voice commands. These are as follows: taring, zeroing, printout/measurement record. The commands must be given in English and in the correct order. Below is the structure of the individual commands.

Tare: **ellipsis [please] (tare | tar | terre) [the] device**

Zero: **ellipsis [please] zero [the] device**

Print/Save: **ellipsis [please] save [the] (mass | measurement | mass measurement)**

How to say the command: black text is mandatory, green - may or may not be spoken, red - one of the texts is mandatory to be spoken

*e.g. for the Print command: **ellipsis save mass.***

Procedure:

1. Place the <  > button for activating voice commands on the button bar (for how to add buttons, read further down this manual).

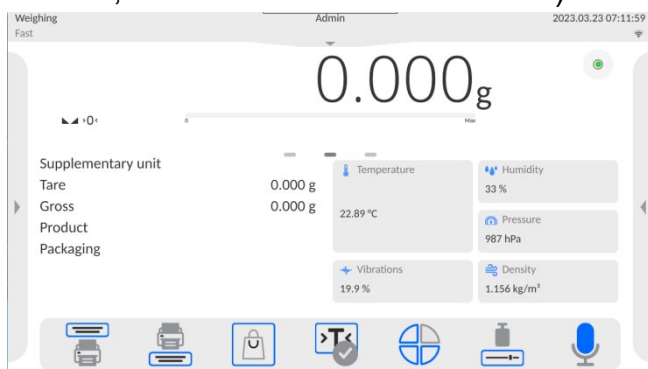

2. Press <  >.
3. The voice command recognition procedure is initiated and the user is informed about it through the displayed messages.

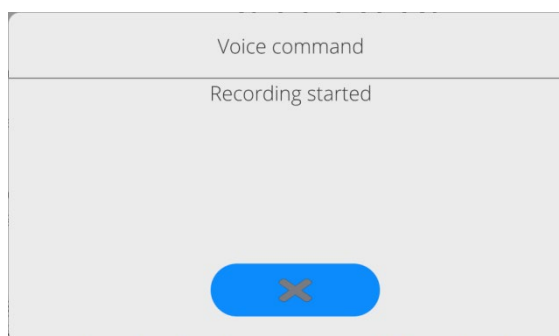
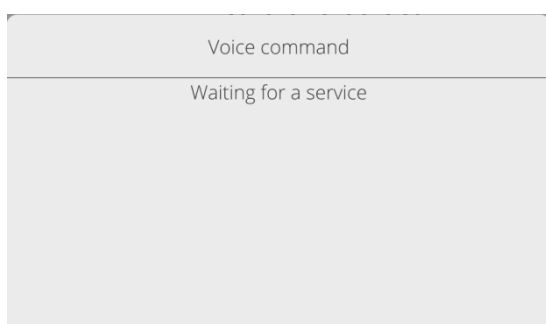

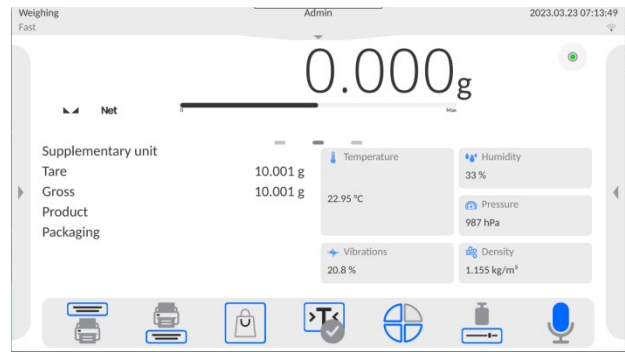
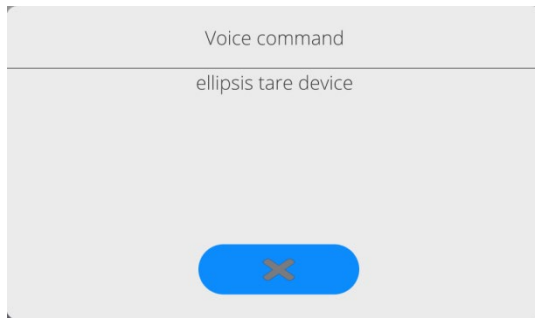

4. Say the command as described above.
5. If the command is spoken correctly and the balance program recognizes the command, a message is displayed and the command is automatically executed.



8.3. Return to Weighing

Modifications introduced into balance memory are automatically saved upon return to the home screen.

Procedure:

- Press  button repeatedly, keep pressing it until you see the home screen.
- Press  button (top bar), the home screen is displayed immediately.

9. ADJUSTMENT

The 5Y series balances feature an automatic internal adjustment system that ensures correct measurement accuracy. The <ADJUSTMENT> menu contains functions for controlling the operation of the adjustment process.

9.1. Internal Adjustment

Internal adjustment is carried out by means of an internal adjustment weight.

The  <Internal adjustment> button, when pressed, automatically triggers the adjustment process. Upon adjustment process completion, a respective message is displayed, informing the user about the process end and its status.





Caution: *The balance adjustment procedure requires stable conditions (no air drafts or vibrations). In the course of adjustment, the weighing pan must be unloaded.*

9.2. External Adjustment

External adjustment is carried out using external mass standards of the right accuracy and weight value, which value depends on the balance model and capacity. The process is carried out semi-automatically; successive process stages are signalled with prompts.

NOTE: To adjust the device using external mass standards, replace the weighing pan with **the one dedicated to checking and adjusting** (supplied with the device as a default).

Procedure:

- Enter the <Adjustment> submenu, next select the <External adjustment> option.
- A message to remove weight is displayed. Unload the weighing pan and press the  button. The balance determines start mass, message: **Mass determination...** is displayed.
- Upon completing the start mass determination, a message ordering you to load the weighing pan is displayed. Load the weighing pan with a weight of the respective mass value and press the  button.
- For some balance types, the next message is displayed. Load the weighing pan with the weight of the subsequent mass value, and press the  button.
- Upon completing the procedure, unload the weighing pan and press the  button to confirm. Balance returns to the weighing process.

9.3. Adjustment Test

<Adjustment test> function enables comparing the result of an internal automatic adjustment with the value recorded in balance factory parameters. The comparison is used for determining drift of balance sensitivity over time.

9.4. Automatic Adjustment

Enter this menu to specify conditions that trigger the automatic adjustment. Options:

- None – automatic adjustment inactive.
- Time – adjustment takes place in time intervals declared in the <Automatic adjustment time> menu
- Temperature – adjustment is triggered by temperature change.
- Both – adjustment is triggered by both, temperature changes and time.

Caution: This parameter's settings can be modified only for balances that are not subject to the conformity assessment (verification).

9.5. Automatic Adjustment Time

The <Automatic adjustment time> parameter determines the time interval between successive automatic internal adjustments. The time interval is declared in hours and ranges between 1 and 12 hours.

To set the time interval for automatic adjustment:

- enter the <Automatic adjustment time> parameter,
- using the displayed menu, select the appropriate time interval (given in hours), which is to elapse between the most recent adjustment and the activation of the following automatic internal adjustment.

Caution: This parameter's settings can be modified only for balances that are not subject to the conformity assessment (verification).

9.6. Report Printout

The <Report printout> parameter determines whether or not an adjustment report is to be automatically printed upon adjustment process completion.

To print the report automatically, set the parameter as active.



9.7. GLP Project

GLP is one of many methods for documenting work in accordance with an adopted quality system. Data selected for printing is printed on each release of an adjustment report.

Information and signs to be used in a GLP report:

adjustment (adjustment type)	working mode (working mode name)
date	time
balance type	balance S/N
operator	first and last name
level status	nominal mass
current mass	difference
nominal mass 2	current mass 2
difference 2	temperature
dashes	empty line
signature	non-standard printout

9.8. Adjustment History

It contains the 50 most recent balance adjustments. The record is carried out automatically. Each adjustment record comprises basic data on the completed process. This menu enables you to display the list of completed adjustment processes. Each report is printable.

In order to print an adjustment report, enter the <Adjustment> submenu, next enter the <Adjustment history> parameter, and select the adjustment to be printed. Record details are



displayed, press <  > print button.

Caution: *If 50 consecutive adjustments are saved, saving the 51st report will delete the oldest record in the list.*

If an organization's internal procedures require complete documentation of all carried out adjustment processes, then the list of adjustment records must be printed and archived on a regular basis.

Searching for an adjustment record

It is possible to search for a specific completed adjustment record. To do that, press the <

  > button and enter the date of the adjustment process that is to be found.

Exporting data on a completed adjustment process

Connect a USB flash drive to the balance USB port. Press the <  > button located in the upper right corner of the display. The process is fully automatic and on its completion, a file with a **.db.** extension is saved to a USB flash drive connected to the USB port.

10. ADMINISTRATOR PANEL

This menu enables to determine: activities to be carried out by an operator with certain permissions, password strength and permissions for unlogged operator.

CAUTION: Only operator with Administrator permissions can modify permission-related parameters.

← Administrator panel

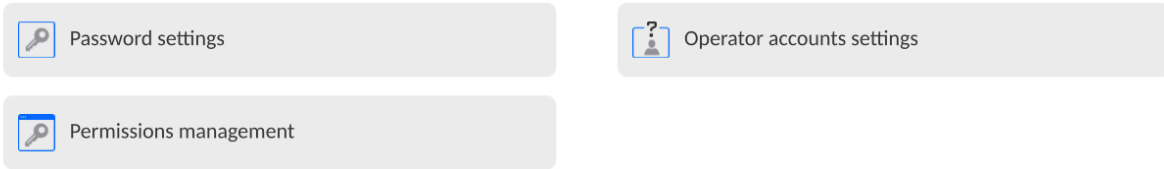

10.1. Password Settings

This submenu is designed to set the password sophistication rate.

← Password settings

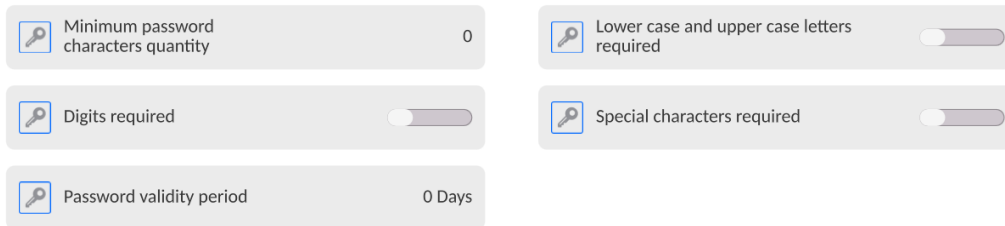

Minimum password characters quantity	Determining the quantity of characters in the operator's password. For the '0' value, set any quantity of characters.
Lower case and upper case letters required	Parameters specifying requirements regarding password character type and format.
Digits required	
Special characters required	
Password validity period	Determining the time interval in days after which the password has to be changed. For the '0' entry, password change is not required.

10.2. Operator Accounts Settings

← Operator accounts settings

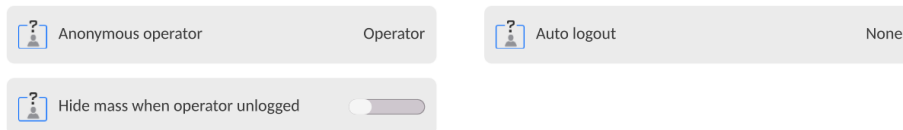

Unlogged operator permissions

An Administrator can assign an unlogged balance operator (so called anonymous operator) with any permission level.

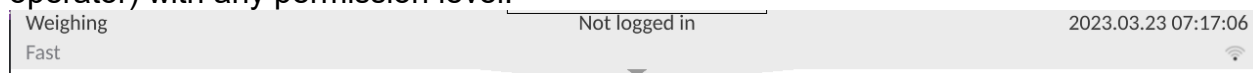

Procedure:

Enter the <Operator accounts settings> submenu, choose <Anonymous operator>, next set the respective permissions: Guest, Operator, Advanced Operator, Administrator.

Caution: An operator with the <Guest> permission level is not permitted to change program settings.

Auto logout

With the Auto logout function on, the operator is logged out automatically if the balance is not operated within a specified time interval, given in minutes.

By default, the function is disabled (<None> entry set).

Procedure:

Enter the <Operator accounts settings> submenu, then select the <Auto logout> parameter and set its value to none/3/5/15/30/60. The time is given in [min].

Hide mass when operator unlogged

Option to disable the mass result display if the operator is not logged in. By default, the function is disabled.

Procedure:

Enter the <Hide mass when operator unlogged> option and set it to “active”.

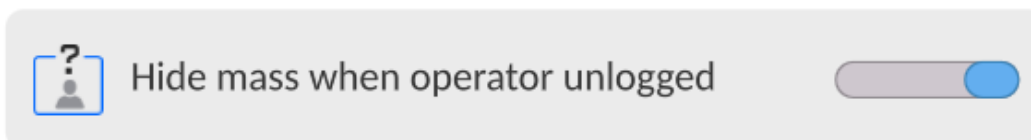

10.3. Permissions Management

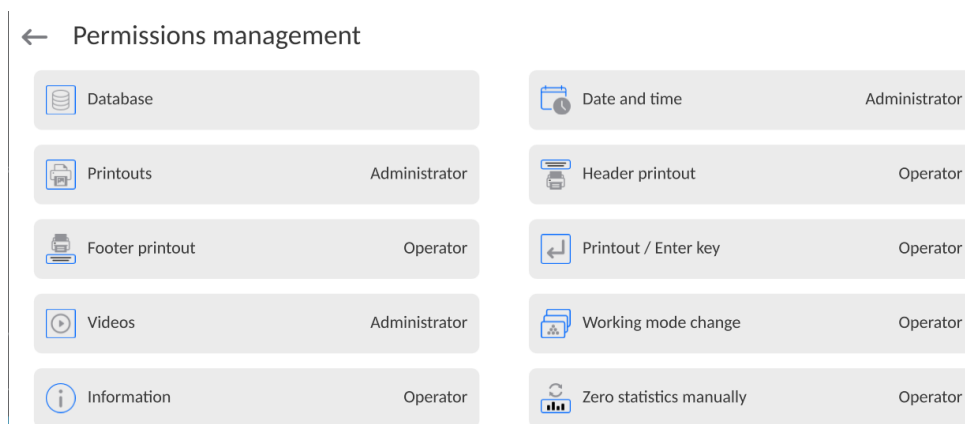

Caution: When the <Guest> option is set for individual parameters, their settings can be freely accessed (there is no need to log in).

Each option can be assigned a permission level to edit it.

Parameter values:

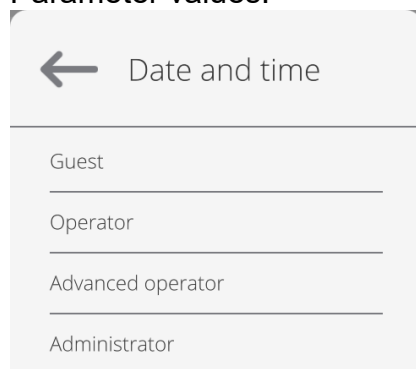

Databases

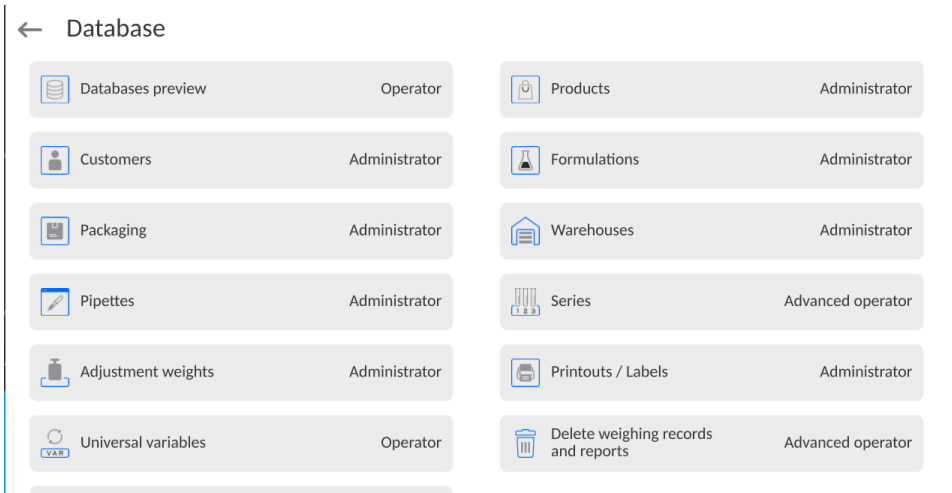

Default balance settings enable an operator who is logged in as an **Administrator** to modify the settings of particular databases. The values can be changed depending on the needs.

The editing permissions for the other options available in this menu can be changed on a similar basis.

10.4. Remote access password

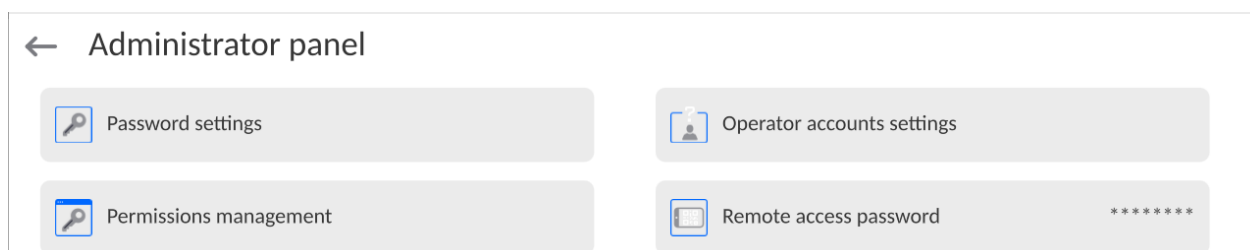

The balance allows you to gain remote access, using connection between the balance and local Internet network that a PC is connected to. The **VNC Viewer** application can be used for this purpose.

A default access password in the program is a sequence of the following characters: **radwag1234**. If the operator does not wish to use the default password, he must enter its own unique access password in the relevant field.

Note: please remember a new password in order not to lose a remote access to the balance.

11. PROFILES

A profile is a data pack that determines:

- a specific function operation, such as pipette calibration,
- data to be displayed during operation,
- function keys to be active,
- measuring units to be accessible,
- criteria determining speed of operation and measurement stability,

Balance software allows you to create numerous profiles This enables:

- designing an individual working environment by each operator,
- customized balance operation, i.e. activating selected function keys and information (improved operation performance).

For ease of operation, four default balance profiles have been designed. The profile settings provide an optimal weighing process for particular requirements and conditions.

Profile types:

- **Fast** – profile set to enable fast measurement of mass of any size regardless of the selected working mode. The fast profile gets activated automatically at the first balance start-up. For the Fast profile, the parameter settings enable obtaining the final result as fast as possible.
- **Fast dosing** – profile intended for dosing. It is set to enable fast dispensing of product. For this profile selected, the DOSING mode gets activated automatically,

- **Precision** – profile configured to allow precise measurement of masses of any size regardless of working mode. For this profile, the weighing process takes a lot of time, but this guarantees the most precise weighing result.
- **User** – basic profile, filter settings allow for quick and accurate measurement. For this profile selected, the WEIGHING mode gets activated automatically.

Caution: As an operator, you can modify all profile settings only for the User profile. When it comes to the remaining default profiles (Fast, Fast Dosing, and Precision), they can only be modified partially. Each additional profile you create can be modified in terms of all settings.



11.1. Creating a Profile

The Administrator can create new profiles by:

- Copying an already existing profile and modifying it,
- Creating a new profile.



Copying an existing profile

Procedure:

- Enter the main menu. To do it, press the  button.
- Enter the  submenu.
- Press and hold the profile that is to be copied.
- A menu referring to the profile record is displayed. Select the <Copy> parameter.
- A new <Name copy> profile is created. The new profile settings and base profile settings are identical.
- Modify the necessary data (name, etc.).

Adding a new profile

Procedure:

- Enter the main menu. To do it, press the  button.
- Enter the  submenu.
- Press the  button.
- A new profile is added automatically. It is opened in an editing mode.



Settings



Working modes





Readout



Units

Deleting a profile

Procedure:

- Enter the main menu, to do it press  button.
- Enter  submenu.
- Press and hold the profile that is to be deleted.
- Menu referring to a profile record is displayed. Select <Delete> parameter.
- Message box: <Delete?> is displayed.
- Press  button to confirm, the profile gets deleted.

Caution: In order to operate profiles, it is necessary to log in as an Administrator.

11.2. Profile Structure

:A list of profile parameters:

- | | |
|----------------------|---|
| Settings | Enter this menu to set an individual profile name (an alphanumeric order of characters), and to declare a default working mode (the selected mode is activated as default upon selecting the profile). |
| Working modes | Option to set specific functions for individual working modes. Mode submenus: <ul style="list-style-type: none">▪ Mode related settings▪ Buttons▪ Information▪ Printouts |
| Readout | Readout submenus: <ul style="list-style-type: none">▪ Filter▪ Value release |

- Autozero
- Autozero: Dosing
- Last digit
- Last digits quantity
- Ambient conditions

Units Enter this menu to declare the start unit, the supplementary unit, 2 custom units; to enter the value of gravitational acceleration force in the balance's operation place; and to declare the availability of individual units.

11.2.1. Settings

Name

Upon entering this parameter, a message box with an on-screen keyboard is displayed.

Enter the name of a profile and press the  button to confirm. The name is assigned to the profile.

Default working mode

Upon entering this parameter, you can select a specific working mode that is to be set as the default. For the <None> value set, upon selecting the profile, the balance activates the most recently used working mode.

11.2.2. Working Modes

Upon entering the Working Modes parameter, a window containing all accessible working modes is displayed. Parameters are set for each working mode independently. A particular profile when activated, runs with a given set of parameters.

A list of parameters shared by all working modes:

- **Settings:**
specific parameters relating to a working mode, and universal settings such as: result control, tare mode, automatic footer printout, printout mode, printout.
- **Quick access button functions:**
declaring quick access buttons to be displayed.
- **Information:**
declaring information to be displayed.
- **Printouts:**
declaring the type of a printout or defining a non-standard printout.

11.2.3. Readout

You can adjust the balance to ambient conditions (filter level) or to your own needs. The <Readout> menu contains the following elements:

FILTER (function disabled for Fast, Fast Dosing, Precision profiles)

Each measurement signal, before being displayed, is electronically processed in order to provide the correct parameters specific to a stable measurement result (ready to be read).

You can determine the signal processing rate. There are five different filters:

Range:

- very fast, fast, average, slow, very slow.

While setting the filter, consider the actual operating conditions. In the case of very good operating conditions, select an average or fast filter. In the case of rough conditions, select slow or very slow filter.

CAUTION:

- *For precision balances, it is recommended to select a very fast, fast or average filter,*
- *For analytical balances and microbalances, it is recommended to select an average, slow or very slow filter.*

Value release (option disabled for Fast, Fast Dosing, Precision profiles)

The parameter has been designed to determine when the stability marker is to be displayed.



There are three different settings:

- fast, fast and reliable, reliable.

Caution: *Both parameters, filter and value release, determine how long it takes to obtain a stable result.*

Autozero function

The function has been designed to enable automatic control and correction of zero indication.

If the function is enabled, the subsequent measurement results are compared to each other at constant time intervals. If the results differ less than the declared AUTOZERO range, e.g. 1 division, the balance is automatically zeroed, and the pictograms of stable indication –  and precise zero –  are displayed. The Active Autozero function means that each measurement starts with a precise zero. There are, however, some cases when this function can be a disturbing factor for the measuring process, e.g. very slow placing of a load on the weighing pan (load adding, e.g. pouring, filling). In such a case, the system correcting zero indication may also correct the actual indication of a load placed on the weighing pan.

Values: **NO** - autozero function disabled.

YES - autozero function enabled.

Autozero function: Dosing (option disabled for Fast, Fast Dosing, Precision)

The function has been designed to enable/disable the autozero function for Dosing.

Options:

NO - autozero function disabled automatically when Dosing mode is run.

YES - autozero function enabled automatically when Dosing mode is run.

Last digit

The function has been designed to enable/disable visibility of the last decimal place of the measurement result. Values:

- **Always:** all digits are displayed.
- **Never:** last digit disabled.
- **When stable:** last digit displayed only when the result is stable.

Last digits quantity

This function enables declaring the number of hidden last digits of the result. The function has three settings and works in connection with the <Last digit> option:

- **1:** the last digit of the result.
- **2:** the last two digits of the result.
- **3:** the last three digits of the result.

Ambient conditions

Parameter relating to the ambient and environmental conditions of the workstation. For unstable ambient conditions, it is advisable to set the parameter to the 'Unstable' value. By default, the parameter is set to Stable.

'Stable' value results with faster operation, i.e. weighing takes much less time than when the 'Unstable' value is set.

- **Unstable; Stable.**

11.2.4. Units

For a selected profile, you can declare a start unit, a supplementary unit, and two custom units.

← Units

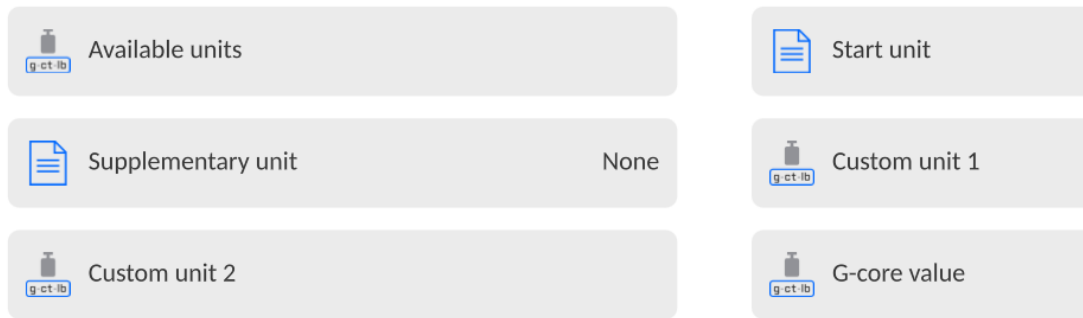

The Units menu enables you to enter the value of the gravitational acceleration force characteristic for a particular place of use. It is therefore necessary that the balance be used to determine mass in [N].

Custom unit features:

- Formula (*custom unit recalculation formula*): Coefficient * Mass or Coefficient / Mass.
- Coefficient (*coefficient for custom unit recalculation*)
- Name (*unique unit name to be displayed next to the result - max 3 characters*)

← Custom unit 1

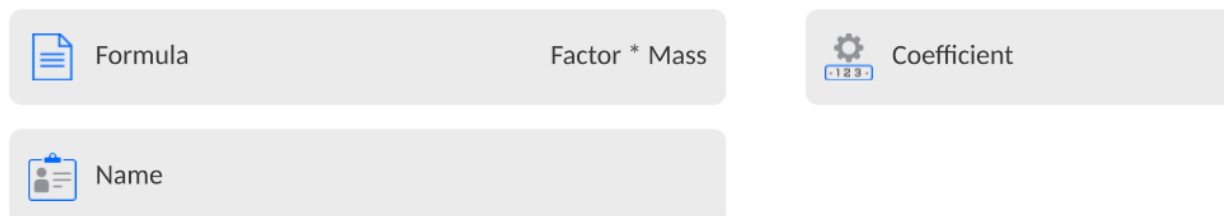

A newly designed custom unit name is added to the list of accessible measuring units (refers to non-verified balances exclusively).

12. WORKING MODES – General Information

NOTE: AP-12 pipette calibration automatic is available in a special design and is used by default only to conduct pipette calibrations. You can use other working modes after replacing the weighing pan with the one dedicated to checking and calibrating the balance (supplied with the device as a default).

The description of operation with particular modes can be found in the user manual of standard 5Y balances.

The 5Y series balances feature the following working modes:

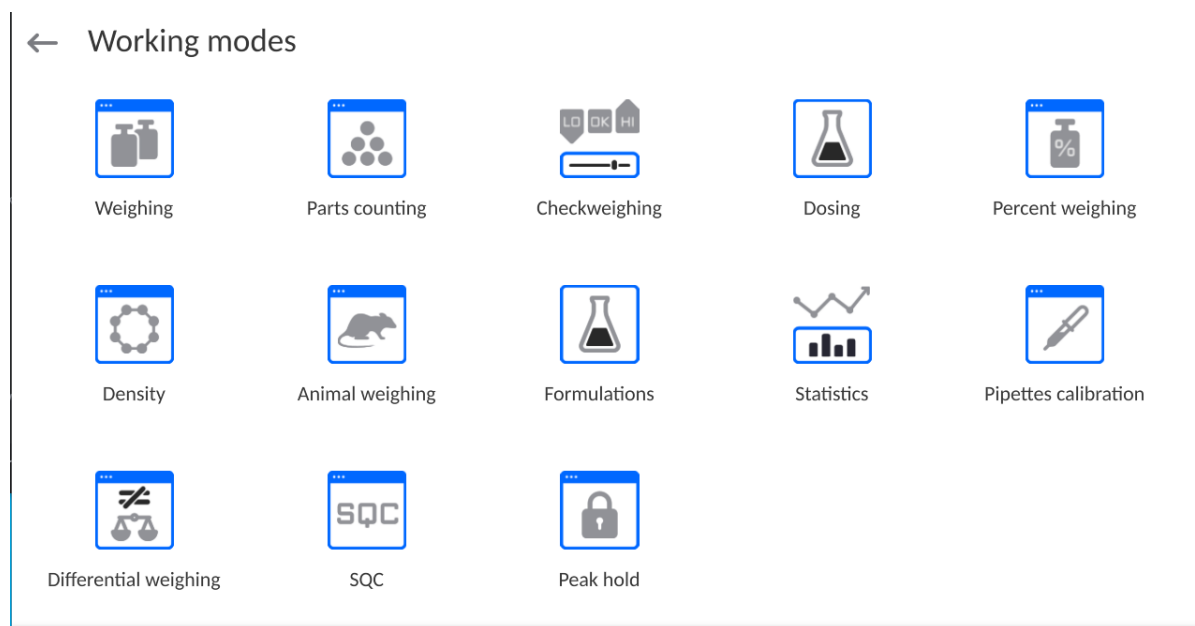

Weighing	Pipette Calibration
<p>Means of operation: the weight of a load is determined through an indirect measurement. The balance measures the gravitational force that attracts the load. The obtained result is processed and displayed on the balance screen in a digital format.</p>	<p>Means of operation: calibration of pipettes in accordance with ISO 8655 standard procedure or with regard to user requirements.</p>

12.1. Running Working Mode

To run a working mode other than the currently operated one:

- Slide down the menu at the top of the display.

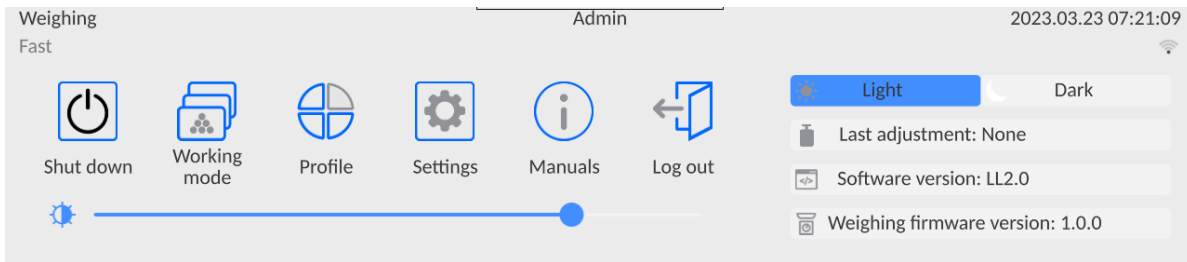

- Press the <Working mode> option
- A list of all working modes is displayed.
- Select the mode that is to be operated. The balance automatically starts the selected mode.

12.2. Working Mode Parameters

Each working mode has programmable parameters determining its functioning.

To access particular working mode parameters:

1. Slide out the menu on the left.

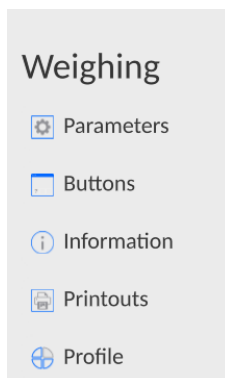

2. The following menu is displayed:
 - <Parameters> - additional options.
 - <Buttons> - quick access buttons configuration.
 - <Information> - setting data that is to be displayed in the workspace.
 - <Printouts> - setting printout type and content.
 - <Profile> - choosing the profile to be used during operation.
3. Enter a particular submenu and select the component that is to be modified.

A description of the basic parameters of the <Parameters> menu is to be found in section 13.6, *Additional Parameters of the Weighing Mode*. For detailed information on all but the basic parameters of particular working modes, read the given working mode section.

12.3. Quick Access Buttons, Proximity Sensors

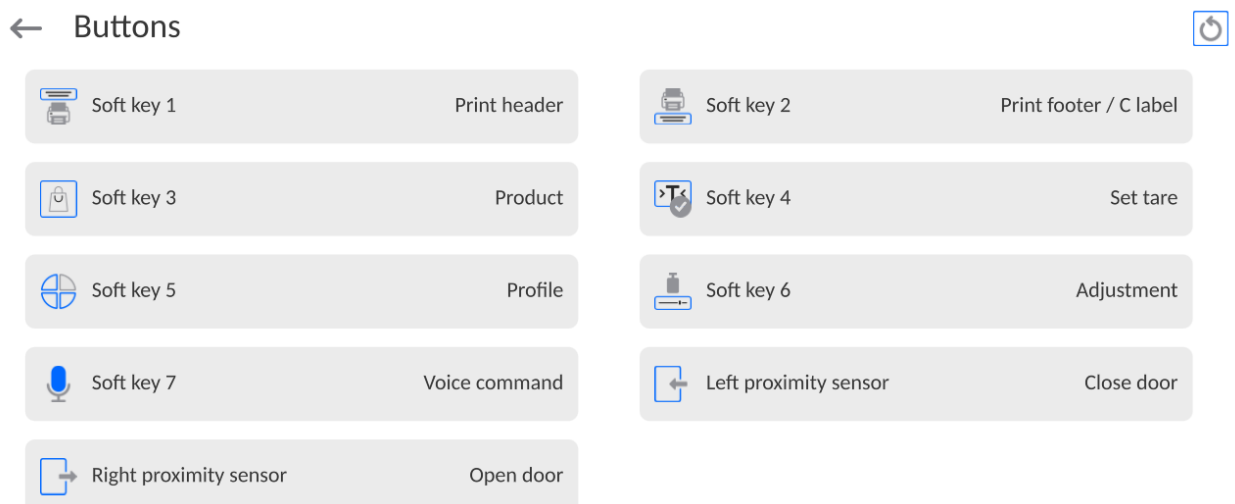

You can quickly restore default key arrangement in the bottom bar of the display, to do it click  button (top right-hand corner).

You can define up to 7 quick access buttons, which are to be displayed in the bottom bar. Upon assigning a function to a button, a corresponding pictogram is displayed in the bottom navigation bar of the home screen. Each working mode features a customized set of buttons. For a complete button list, read Annex B. These are so-called “quick access buttons” for triggering the most frequently performed operations.

Another way to add or change a button is to press and hold a field in the button bar for about 3s.

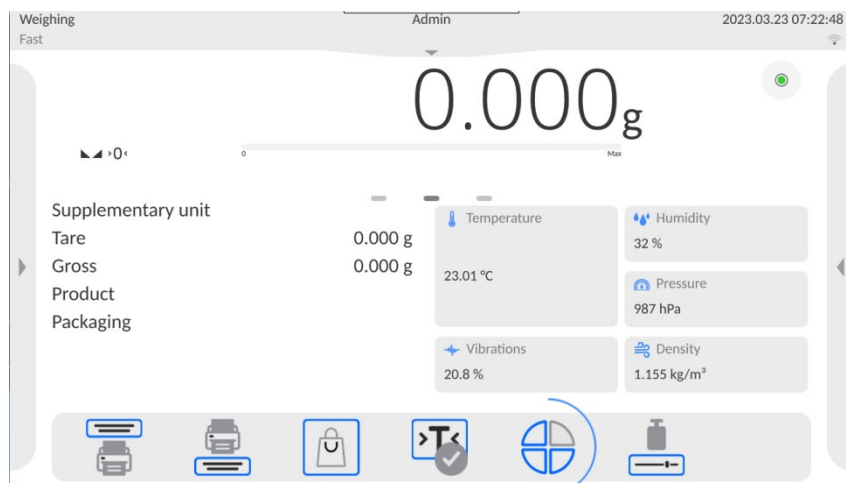

A window with the available buttons is displayed automatically.

← Available actions

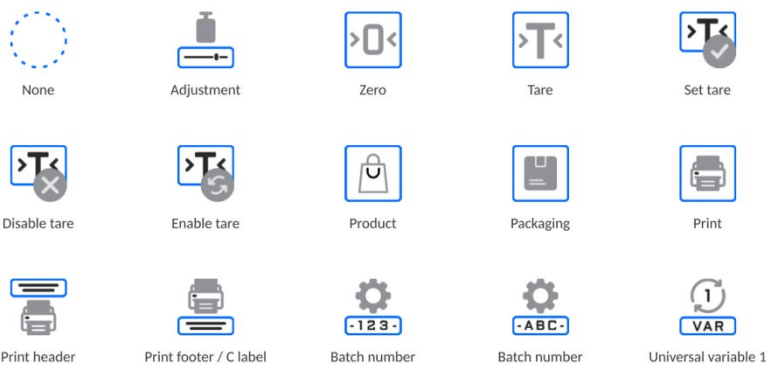

Press the respective button; the software returns to the home screen, and the selected button appears in the place where it was activated.

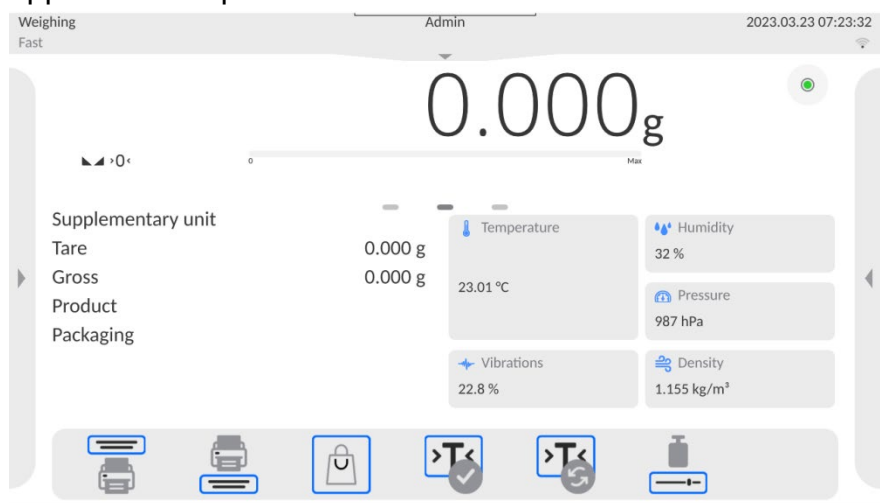

Caution: You can view the user manual saved to the balance memory. In order to take advantage of this function, add Help  button to the tool bar.

12.3.1. Proximity Sensors

The balance is equipped with two proximity sensors, which enable touch-free control.



The program detects four motions performed around the sensors:

1. Hand in a close vicinity to the left sensor <Left proximity sensor>.
2. Hand in a close vicinity to the right sensor <Right proximity sensor>.

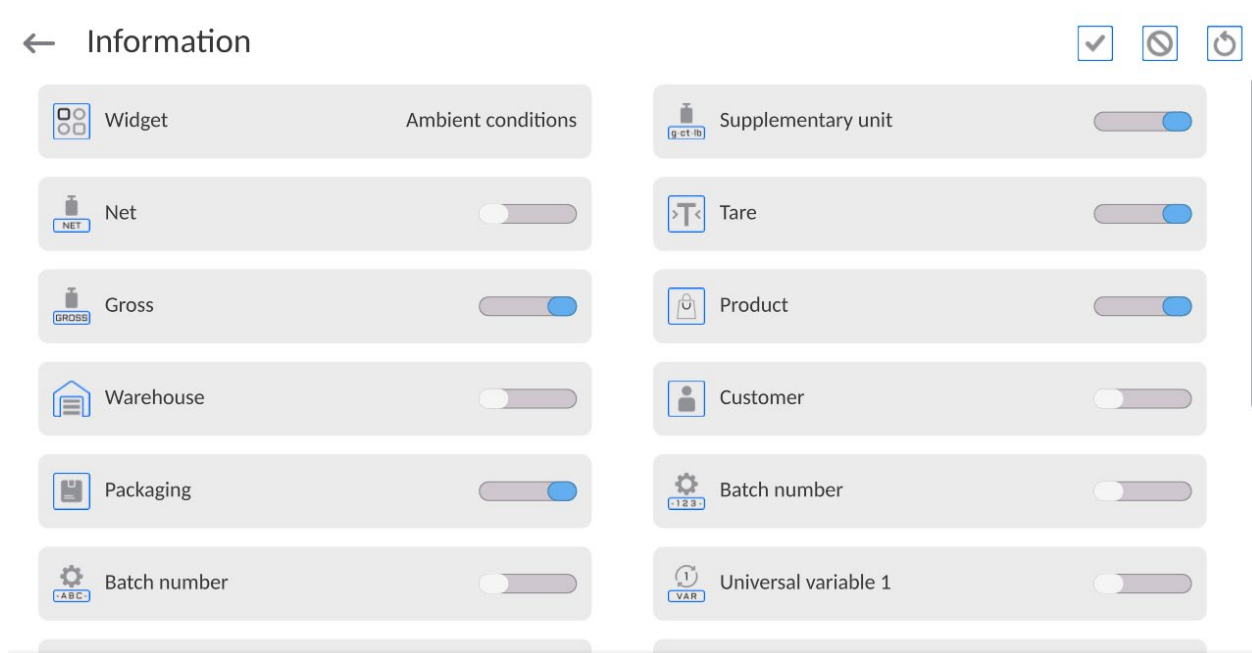
12.4. Information



You can quickly select/deselect info to-be-displayed, to do it use top right-hand corner buttons.

	Press to deselect all marked information.
	Press to select all marked information.
	Press to restore default settings.

Information related to the weighing process is displayed on the left side of the display.

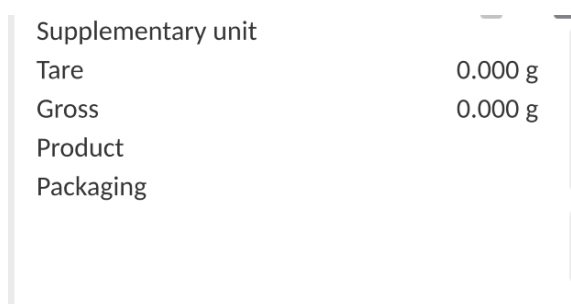

The workspace can contain up to six data. Mind that if you select more, only the first six of them are displayed.

Each parameter features two options:

-  – data enabled.

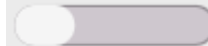
-  – data disabled.

12.5. Printouts

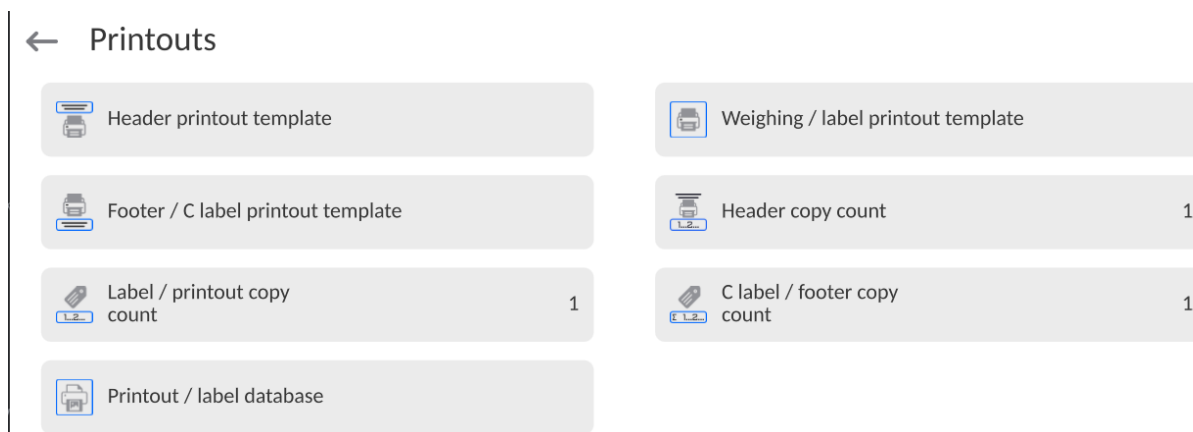

<Printouts> menu comprises three setting sections:

1. Standard printouts: <Header printout template >, <Weighing/label printout template>, <Footer/C label printout template>,
2. Non-standard printouts: <Printout/label database>
3. Parameters enabling to set how many times the header, the weighing section, the footer, is to be printed upon single pressing of the button triggering particular printouts.



Standard printout comprise 3 sections featuring numerous variables. Set for each variable that is to be enabled on the printout, set for each variable that is to be excluded from the printout.

To quickly change the settings press buttons located in the top right-hand corner.

	Press to deselect all marked variables.
	Press to select all marked variables.
	Press to restore default variables.



Procedure:

1. Press name of a selected template (Header – GLP Printout – Footer) and select variables that are to be printed.
2. If a printout is a non-standard one, create it.



<u>HEADER</u>	<u>GLP PRINTOUT</u>	<u>FOOTER</u>
<ul style="list-style-type: none"> – Non-standard printout – Dashes – Working mode – Date 	<ul style="list-style-type: none"> – Non-standard printout – N (measurement number) – Date – Time 	<ul style="list-style-type: none"> – Non-standard printout – Working mode – Date – Time

<ul style="list-style-type: none"> - Time - Balance type - Balance S/N - Operator - First and last name - Level status - Customer - Warehouse - Product - Packaging - Universal variable 1 ... 5 - Empty line - GLP report - Non-standard printout 	<ul style="list-style-type: none"> - Level status - Customer - Warehouse - Product - Packaging - Universal variable 1 ... 5 - Net - Tare - Gross - Current result - Supplementary unit - Mass - MW-Method - Reference tare - Minimum sample - Minimum sample status - Mass value for a titrator - ID - Non-standard printout 	<ul style="list-style-type: none"> - Balance type - Balance S/N - Operator - First and last name - Level status - Customer - Warehouse - Product - Packaging - Universal variable 1 ... 5 - Dashes - Empty line - GLP report - Signature - Non-standard printout
--	---	---

HOW TO OPERATE PRINTOUTS

1. In order to print variables of the GLP PRINTOUT section, press  button on the operation panel; only variables with  attribute can be printed (see the above list).
2. Variables with  attribute, present in the HEADER and FOOTER, are printed **ONLY** upon pressing **PRINT HEADER** and **PRINT FOOTER** pictograms. The pictograms have to be added to the bottom bar of the display as quick access buttons.

(For detailed instruction on how to add quick access buttons to the bottom bar of the display, go to section 12.3)

	
Print header data	Print footer data

CAUTION:

Measuring units for mass indication:

- Net – the main measuring unit (adjustment unit)
- Tare – the main measuring unit (adjustment unit)
- Gross – the main measuring unit (adjustment unit)
- Current result – currently displayed measuring unit
- Supplementary unit – supplementary measuring unit
- Mass – the main measuring unit (adjustment unit)

Non-standard printout

Non-standard printout may contain: TEXTS and VARIABLES (acquired from the software during printout). Each non-standard printout is a separate project, featuring a specific name by which it is identified and saved to the database of printouts.

Procedure:

1. Press <Non-standard printout> entry.
2. Press <Add>  button, window featuring Name/Code/Project data opens.
3. Set name and code of a printout.
4. Press <Project> button.
5. Printout edit box with an on-screen keyboard is displayed.
6. Use the keyboard to design printout template, the printout may contain texts and variables.

CAUTION:

- *It is possible to add a printout by import of configured texts from flash drives connected to balance's USB port.*
- *Printout's name is ONLY a NAME, and it is not part of its content.*
- *For information on how to design a non-standard printout template, read section 15.7 Printouts.*



12.6. Profiles

The profiles function has been described in section 11 *Profiles*.

13. WEIGHING

Load the weighing pan. Wait for a stable indication (stability marker, ) and read the measurement result.

A record/printout of the measurement result is available upon pressing the  PRINT key:

- for verified balances – only stable measurement results are saved or printed (stability marker  visible on the balance's display),
- for non-verified balances – stable and unstable measurement results are saved or printed (regardless of the stability marker  absence). For unstable measurement results, a question mark <?> is printed next to the mass value.

13.1. Weighing Unit Selection

The change of the weighing unit is carried out by pressing the weighing unit pictogram visible next to the measurement result. Upon pressing the weighing unit, a list of available units is displayed. Select the unit you need, the software automatically recalculates the indicated value.

Options:

<i>unit</i>	<i>symbol</i>	<i>verified balance</i>	<i>Unit</i>	<i>symbol</i>	<i>verified balance</i>
gram	[g]	Yes	Taele Singapore	[tls]	No
milligram	[mg]	Yes	Taele Taiwan	[tit]	No
carat	[ct]	Yes	Taele China	[tlc]	No
pound	[lb]	No	Momme	[mom]	No
ounce	[oz]	No	Grain	[gr]	No
ounce Troy	[ozt]	No	Tical	[ti]	No
pennyweight	[dwt]	No	Newton	[N]	No
Taele Hongkong	[tlh]	No	Mesghal	[msg]	No

For non-verified balances, all non-SI units are available.

13.2. Good Weighing Practice

To assure long-term operation and correct mass measurements, follow the rules presented below:

- Start the balance with no load on the weighing pan (permissible load value on the weighing pan at start is $\pm 5\%$ of the maximum capacity).

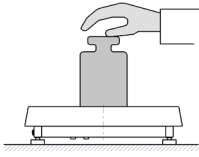
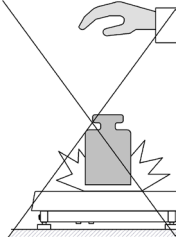
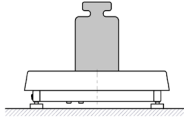
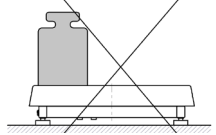
▪ YES	NO	YES	NO
			
Load the weighing pan steadily avoiding shocks: Go to Setup/Misc./Vibrations detection parameter and enable control of weighing pan loading (for detailed information, read section 19.8).		Place weighed loads centrally on the weighing pan.	

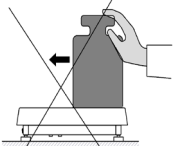
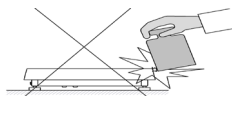
NO	NO	
		
Avoid side loading, in particular side shocks.		



Prior to weighing or in the case of ambient conditions changing, it is necessary to carry out balance adjustment.

- Prior to the measurement, it is recommended to load the weighing pan several times with mass close to the maximum capacity. In the case of instruments offering two reading units (d), the initial load of the weighing pan depends on the reading unit value.

Example: For the XA 82/220.5Y balances with $d_1 = 0.01\text{mg}$ and $d_2 = 0.1\text{mg}$, load the weighing pan as follows: 50 g weight for measurements with $d_1 = 0.01\text{mg}$ and 200 g weight for measurements with $d_2 = 0.1\text{mg}$.

- Make sure that the unloaded weighing instrument indicates zero (± 0 pictogram) and check whether the measurement is stable ($\blacktriangleleft\blacktriangleright$ pictogram); if not, press the  button.

0.0000g or

- Select the weighing unit: press the unit next to the result  press the  w button at the bottom of the display.



Caution: In accordance with the EN 45501 standard, verified balances cannot display mass values below $-20e$. If the indication value is below $-20e$, <Lo mass> information is displayed.

Press  key to zero the balance.

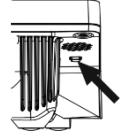
Do not unplug the balance from the mains between measurement series. It is recommended to switch off the display with the button in the upper slide-down menu of the balance.	
To start the balance, press the key on the indicator. Once the start-up procedure is complete, the balance is ready for subsequent weighings.	



13.3. Levelling

The balance is equipped with an **Level Sensing System**. System, which enables monitoring of the balance level. This solution enables continuous monitoring of the balance level during operation, which is signalled in the upper right corner of the display. The system monitors the balance level state. If the level changes, the system signals it by changing the position of the level indicator and/or by triggering an alarm and going to the balance levelling screen.

Levelling procedure

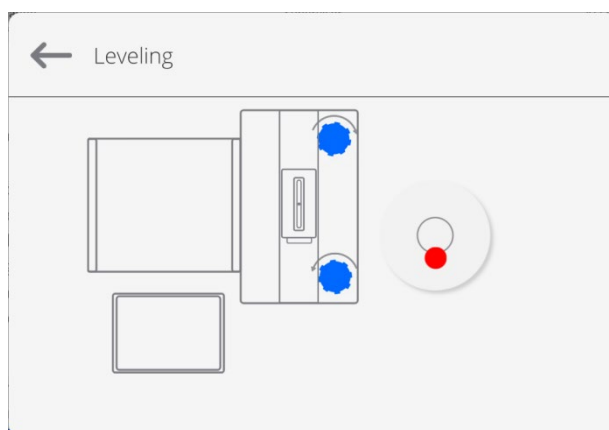
- Press the level status pictogram <  >. It is displayed in the upper right corner of the operation panel.
- The control panel for the levelling function is displayed. Along with the level indicator, a balance view is presented.





- Level the balance by turning its feet left/right, follow the blinking pictograms, <  > – press to make the level marker move toward the centre of the circle.
- When the marker is in the centre, its colour changes from red to green , indicating that the balance is correctly levelled.
- Press  button to return to the home screen.

CAUTION:



The balance is equipped with an Automatic Level Control mechanism. For detailed information regarding the mechanism operation, refer to section 19.8 of this user manual.

13.4. Balance Zeroing

To zero mass indication, press the  key. The zero indication and the following pictograms are displayed: $\rightarrow 0 \leftarrow$ and . A zeroing operation means determining a new zero point, recognized by the balance as a precise zero. The balance can be zeroed only when the indication is stable.

Caution: *Indication can be zeroed only within $\pm 2\%$ range of the maximum capacity. If the zeroed value is above $\pm 2\%$ of the maximum capacity, then the software indicates a respective error message.*



13.5. Balance Taring

To determine the net weight value, load the weighing pan with a packaging, wait for a stable indication and press the  key. The zero indication and the following pictograms are displayed: **Net** and . Upon weighing pan unloading, the sum of tared masses with a minus sign is displayed. You can assign a tare value to a particular product stored in the database. In such a case, the assigned tare value is automatically acquired upon selection of the given product.

Caution: *Negative values cannot be tared. When you try to tare negative values, the weighing instrument responds with an error message. In such a case, zero the indication and repeat the taring procedure.*

Entering tare value manually

Procedure:

- Press the  quick access button. The button is available regardless of the working mode you operate.
- An on-screen numeric keyboard is displayed.
- Enter the tare value and press the  button.
- The balance returns to weighing mode. A tare value with a „-“ sign is displayed.

Deleting Tare

The displayed tare value can be deleted by pressing the ZERO key on the operation panel, or by using the programmable <Deactivate tare> function button.



Procedure 1 - upon taking the tared load off the weighing pan:

- Press the  button,
- the <Net> marker gets deleted, a new zero point is determined.

Procedure 2 - with tared load resting on the weighing pan:

- Press  button,
- the <Net> marker gets deleted, a new zero point is determined.
- when the tare value exceeds 2% of the maximum capacity, an -Err- message is displayed in order to notify you that the operation cannot be completed.

Procedure 3 - when the tared load is on the weighing pan or upon taking the tared load off the weighing pan:

- press  Deactivate tare> programmable button,
- the NET marker is deleted,
- the display indicates the tare value,
- to restore the last tare value, press the  Restore tare> button.

13.6. Additional Parameters for a Weighing Process

Modification of the weighing functions enables programming of balance operation.

Procedure:

- Slide out the menu.
- The following submenus are displayed: Settings, Buttons, Information, Printouts.
- Enter a particular submenu and select the component that is to be modified.

<Settings> - additional options related to the weighing mode,

<Keys> - defining quick access buttons,

<Information> - supplementary data on the weighing process displayed in an Info field,

<Printouts> - selecting printout type,

<SETTINGS> - weighing-process- related data such as:

Tare mode	SINGLE mass value saved to the balance memory on a single pressing of the TARE key. Subsequent pressing of the TARE key determines a new tare value. Selecting a product or packaging to which a tare value is assigned causes the automatic deletion of the previously assigned tare value.
	CURRENT SUM total value of currently entered product and packaging tare values (result of selection of product and packaging from the database) with possibility to add tare value entered manually. When a new tare value for a product or packaging is set again, then the tare value entered manually gets deactivated.
	TOTAL SUM total value of all entered tare values
	AUTOTARE <u>Means of operation:</u> Each first stable measurement result is tared. The NET sign is displayed. Now you can determine the net mass of the weighed load. Upon unloading the weighing pan and autozeroing, the tare value is automatically deleted.
	EACH MEASUREMENT: possibility to tare prior to each measurement in the series
Printout / Release mode	PRINT/RELEASE BUTTON (manual activation after pressing ) <ul style="list-style-type: none"> • Never – printout disabled. First stable – first stable measurement is recorded. • Each stable – all stable measurements are recorded. • Each – printout of all measurements (stable and unstable), for verified balance, only stable measurements are printed out (as in <Each stable> setting).
	AUTOMATIC MODE <ul style="list-style-type: none"> • Never – printout disabled. • First stable - first stable measurement is recorded upon loading of the weighing pan with a load; the recording of the next stable measurement result takes place only if the following conditions are met:

	<p>the weighing pan gets unloaded, measurement value lower than the value of the set threshold is displayed, a new load is placed on the weighing pan.</p> <ul style="list-style-type: none"> • Last stable - last stable measurement, registered prior to unloading, is recorded. The record takes place only if the following conditions are met: weighing pan gets unloaded, measurement value lower than the value of the set threshold is displayed. • With interval – select this value to start the automatic printout and recording of indications to the WEIGHINGS database, carried out periodically at a predetermined time interval. The interval is set in [min] in <INTERVAL> parameter. The interval range is 1 s - 9 h 59 min 59 s. <p>Caution: <i>Each weighing result is printed and recorded (stable and unstable for a non-verified balance; stable for a verified balance).</i></p> <p><i>Automatic operation with an interval starts at the moment of switching the function on. The first stable weighing result of a value greater than the THRESHOLD value is printed and recorded as the first measurement. The following measurements are printed with the frequency set in the INTERVAL parameter. To stop the automatic operation with the interval, switch the option off.</i></p>
	<p>THRESHOLD: Mass value obligatory for operation of automatic printout, set in grams.</p>
	<p>INTERVAL Record frequency for automatic operation with an interval</p>
<p>Air compensation buoyancy</p>	<p>Parameters allowing you to switch on the compensation and to enter weighed sample density data and air density data.</p> <p>Note: <i>This function is active in the weighing mode only. The description of operation and settings can be found in the standard 5Y balance user manual.</i></p>
<p>Minimum Sample</p>	<p>Weighing mode settings comprise <Minimum sample> function. In order to use the function, it is necessary to enter data related to minimum sample determination methods, and minimum sample values for a given method.</p>

	<p>The data must be entered into the <Minimum sample> database. The database is empty in the standard balance version.</p> <p>Determining minimum sample and adding data to the <Minimum sample> database can be carried out by an authorized “RADWAG” personnel exclusively.</p> <p><i>Note: The description of operation and settings can be found in the standard 5Y balance user manual.</i></p>
--	---

13.7. Ambient Conditions - Vibrations

Vibrations are a major cause of errors. Since vibrations spread in all directions, vibration analyzers and meters must carry out measurements in three axes concurrently. Ambient conditions module implemented in RADWAG balances of 5Y series features such option.

Analytical balances are precise weighing instruments; therefore, even insignificant oscillations influence their operation. Humans are most often unable to sense vibrations. In order to detect them, it is necessary to use special equipment. Vibration sensor, along with a module that analyses the influence of the vibrations onto the measurement, informs the user in real time on the possibility of occurrence of errors caused by high-frequency vibrations.

Usually the vibrations are dampened with use of anti-vibration tables. A signalling device, i.e. ambient conditions module equipped with a vibration sensor, is used to support the process of vibrations dampening. Such device comes standard with each 5Y series balance. With use of the said signalling device, it is possible to evaluate workstation conditions and, if necessary, to find more convenient place of use. It is often impossible to find a place where no vibrations occur, however the signalling device allows the operator to determine when and where to expect vibrations of the lowest-frequency.

Due to the following 3 factors: specified values of free vibrations, resolution, and permissible weighing instrument errors, the analysis must be carried out with regard to the right effective value (rms value) and bandwidth. Such analysis is performed on each 5Y series balance in real time.

In the case of the module that is an integrated part of the balances manufactured by RADWAG, the filters analyse those frequencies to which the weighing devices are sensitive. In the case of balances, effective value (rms value) measured from 3 axes and for a particular time interval is given, such value provides information on amplitude and history of disturbances.

Radwag has designed an analysis method and selected permissible vibration thresholds respectively to make signalling device operation both effective and convenient (not troublesome). Balance screen displays balance-registered vibration level in percent.

Vibration threshold cannot be changed, however the operator can modify settings in a way ensuring that alerts are displayed in the most convenient way, depending on the needs. By default, the set value is 100%.

Example of settings modification:

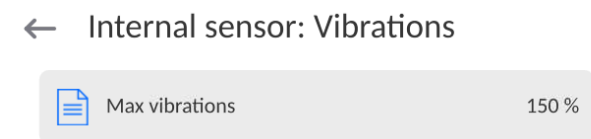
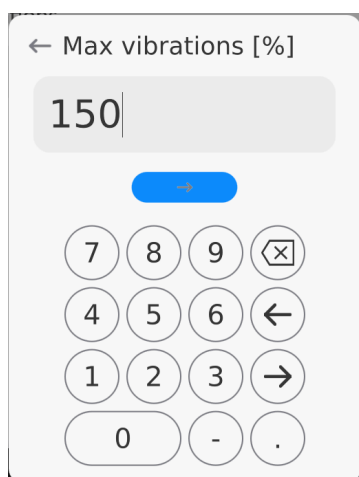
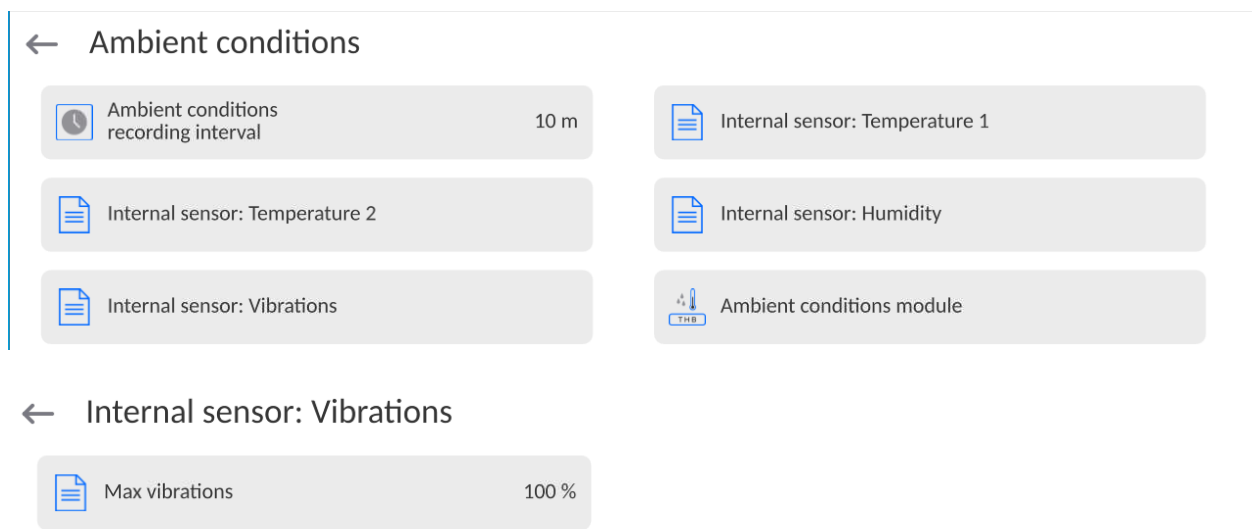

For better understanding, analyse the following example (the values used below are exemplary ones, they were not taken from the balance).

1. Assumed vibration threshold set by default on 5Y series balance: 100 mm/s^2 .
2. Max vibrations value: 100% (threshold for alert– pictogram colour change, from green to red). Pictogram colour is green for vibrations within $0 - 100 \text{ mm/s}^2$ range, for vibrations value of 101 mm/s^2 , the pictogram changes to red.
3. Max vibrations value: 150%. Pictogram colour is green for vibrations within $0 - 150 \text{ mm/s}^2$ range, for vibrations value of 151 mm/s^2 , the pictogram changes to red.

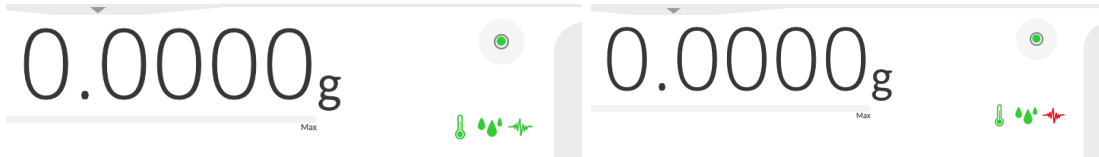

Vibrations are signalled by a respective pictogram displayed in the weighing result window.

A window with the current sensor values is presented in the middle of the display on the right. Displayed vibration value (Vibrations) is the effective value registered within the most recent 2 seconds. This value is refreshed every 2 seconds. If the screen displays 100%, this means that vibrations have reached the threshold set by RADWAG.

Temperature 23.13 °C	Humidity 34 %
Vibrations 21.8 %	Pressure 987 hPa
	Density 1.155 kg/m ³

Vibrations are recorded in the database, this allows to analyse the history of ambient conditions quality.

← Ambient conditions

2023.03.21 09:26:48	2023.03.21 09:24:52
2023.03.21 09:22:38	2023.03.21 09:20:12
2023.02.27 10:03:21	2023.02.27 09:56:31
2023.02.27 09:52:41	2023.02.27 09:50:27
2023.02.27 09:44:50	2023.02.27 09:42:30
2023.02.27 09:38:53	2023.02.27 09:27:36

← Edit record



Date	2023.03.21 09:27:00	Air density	1.155 kg/m ³
Temperature 1	23.13 °C	Temperature 2	23.57 °C
Humidity	34 %	Pressure	987 hPa
Vibrations	0 %		

The effective value of vibrations registered by the balance over a declared time interval is saved (from the moment of the last record) – Setup/Ambient conditions/Ambient conditions recording interval.

← Ambient conditions

Ambient conditions recording interval	10 m	Internal sensor: Temperature 1	
Internal sensor: Temperature 2		Internal sensor: Humidity	
Internal sensor: Vibrations		Ambient conditions module	

By default, the interval is set to 10 min; this value may range between 1 - 60 min. Record analysis allows the user to select the optimal time of the day for the measurements to be carried out, i.e. the time when the ambient conditions influence the vibrations the least. Mind that there are places where the most convenient working conditions occur after-hours.

Along with each measurement, data on ambient conditions alerts and level of vibration that occurred in the course of the measurement are saved.

← Weighing records



2023.03.21 09:34:49	19.993 g	2023.03.21 09:34:42	10.001 g
2023.03.21 09:34:35	0.806 g	2023.03.21 09:34:30	1.477 g
2023.03.21 09:34:29	1.477 g	2023.03.21 09:34:24	0.671 g
2023.03.21 09:34:24	0.671 g	2023.03.21 09:34:18	1.477 g
2023.03.21 09:34:11	0.806 g	2023.03.21 09:34:04	0.670 g
2023.03.21 09:33:56	10.001 g		

← Edit record



Air buoyancy compensation No

Operator Admin

Working mode Weighing

Packaging

Level status Yes

Air density 1.155 kg/m³

ID 2

Product

Customer

Warehouse

Result control

Ambient conditions alerts No

Vibrations 34.3 %

Weighing platform number 1

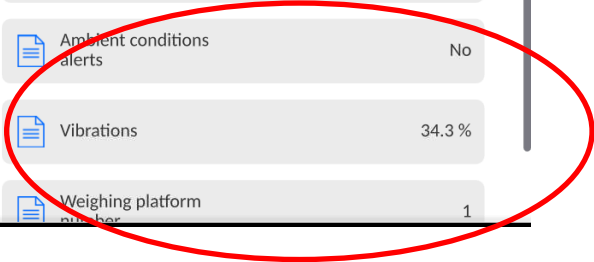

14. PIPETTE CALIBRATION

The balance allows calibrating pipettes with the use of a special weighing program function or cooperating with **RADWAG WEB EDITOR Pipette calibration application**.

AP-12.5Y balance with calibration kit for multichannel pipettes:

View of the assembled balance (a description of the balance preparation can be found in section 3 of this user manual).

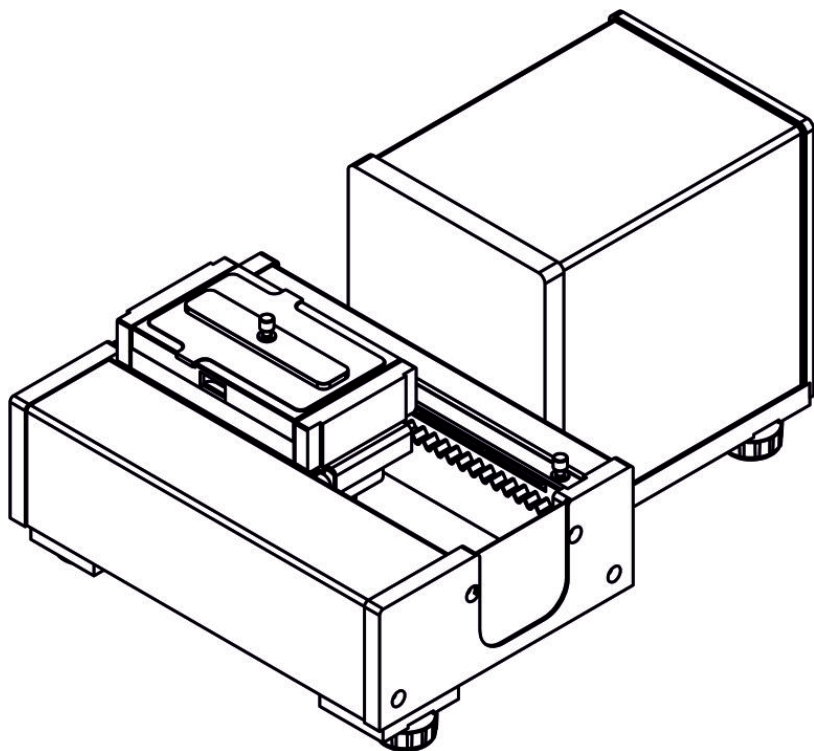

The evaporation ring minimizes measurement errors being a result of liquid evaporation occurring in the course of the weighing process.

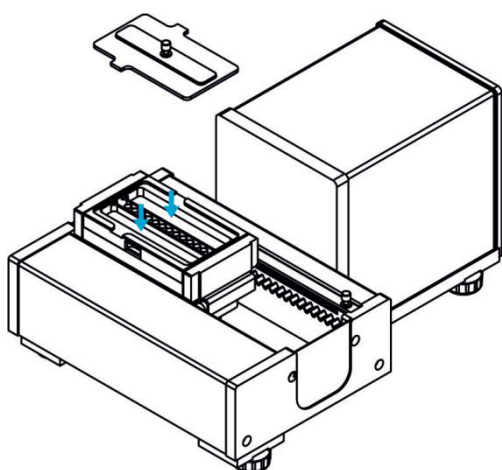

Prior to pipette calibration, distilled water must be poured into the evaporation ring; the amount of water cannot exceed $\frac{2}{3}$ of the ring height. The set may be operated after about an hour – this period of time is required for humidity stabilisation. Remember to control the level of distilled water – the surface of the vessel has to remain covered with it. Excess water may be removed by means of an automatic aspirator or an external pipette.

In order to minimize changes in moisture content inside the weighing chamber, the liquid has to be dosed by means of a pipette through an opening located in the top cover/lid of the weighing chamber.

Now pipette calibration can be carried out.



The < Pipettes calibration > is a working mode allowing you to determine the errors in measurement of piston pipettes volume. The errors can be determined either with reference to the ISO 8655 standard or your own requirements.

In the case of a calibration carried out with reference to the ISO 8655 standard, the errors are automatically selected for a particular volume, as specified in the standard (refer to: table of errors, ISO 8655 standard).

Pipette calibration mode enables:

- calibrating pipettes of fixed-volume or variable-volume, and single- or multi-channel pipettes.
- creating pipettes database providing the following information: pipette name, code, tested volume, etc.
- calculating results on the basis of:
 - average volume of a pipette (channel)
 - systematic error e_s (accuracy error) ,
 - random error CV (repeatability error),
- carrying out automated measuring procedures conditioned by the pipette type,
- storing calibration results in a database (in the form of reports on the calibration process),
- printing reports on pipette calibration processes,
- exporting test reports.

During the procedure, the accuracy and repeatability errors are determined for the tested volume. In the case of pipettes with adjustable volume, the software enables declaring up to 5 volume values (from the total pipette's range) that are to be checked during the calibration process.

Use only distilled water for pipette calibration.

Ambient conditions crucial for high-accuracy calibration:

- The ambient temperature of the pipette, tip and liquid:
20°C ÷ 25°C, during weighing it must be stabilized within $\pm 0.5^\circ\text{C}$
- Relative humidity: 50 ÷ 75%.

- The pipette, tips and distilled water have to be subjected to temperature stabilization carried out directly in the weighing room. The standard recommends acclimatization for at least 2 hours.

While calibrating pipettes, **use the pipettes database** providing you with pipette-related data, parameters, tested volume, and error values determined for specific volumes.

Prior to the pipette calibration process, enter the pipettes database and provide pipette-related data and calibration criteria. In order to add a pipette, it is necessary to enter the database. For information on how to add a pipette to the pipettes database, read further down this user manual.

Pipettes Calibration mode screen



Button functions:



- press to select pipette for calibration from the database



- press to select pipette calibration order



- repeat last pipette calibration order



- press to move the transport cart to a specific position. This option is only applicable when using the transport cart adapter (12 tubes).

After selecting the option, a window is displayed to indicate the position on which the tube transport cart is to be placed.



14.1. Adding Order

Adding an order is possible via the following program: ***Radwag Web Editor - pipette calibration***.

Working with the program is intuitive and allows you to easily add data to the balance (e.g. operators, pipettes, orders), view reports, and print them.

The connection to the program is made using the balance IP for communication via ETHERNET, and the login and password for the operator of the balance.

To see how to run the application and work in the application, read the user manual: ***IMKU-1111-01-xx-xx-PL***.

14.2. Mode Related Settings

The supplementary settings enable you to adjust the working mode to your needs and requirements. To access the settings, follow the below procedure.

Procedure:

1. Move the side left menu.
2. The following submenus are displayed: Parameters, Buttons, Information, Printouts, Profile.
3. Select the <Parameters> menu.
4. The display indicates functions related to pipette calibration process.

← Parameters



Measurements quantity 10	Request serial number <input type="checkbox"/>
Operation with adherence to ISO 8655 <input type="checkbox"/>	Order 'As-Left' calibration automatically <input type="checkbox"/>
Upload ambient conditions parameters from THB module <input type="checkbox"/>	Start-up weighing cycles quantity 1
Print intermediate results in real time <input type="checkbox"/>	Maximum cycle fill count 5
Tare mode Single	Automatic footer / C label printout
Printout / Enter mode	Statistics Global

Measurements quantity	Intended for determining measurements quantity for tested pipette volume (valid for each tested volume in the case of a pipette with adjustable volume),
Request serial number:	YES/NO. YES – a window with an on-screen keyboard is displayed; use it to enter the serial number of a pipette.
Operation with adherence to ISO 8655	YES/NO. YES – the software automatically takes error values accordant with recommendations of the ISO 8655 standard (if other error values have been defined for a particular pipette, then on selecting <Operation with adherence to ISO 8655> parameter, the specified error values are neglected and replaced by those from the ISO standard).
Order 'As-Left' calibration automatically	Option allowing automatic creation of the order for calibrated pipette after the end of the first calibration (data in the order are identical, yet supplied with a note that this order has been 'adjusted'). After the second calibration, data from both will be included in the report generated.
Upload ambient conditions parameters from THB sensor	YES/NO. YES – the software automatically acquires and saves ambient conditions from a connected THB sensor at a right time. NO – you have to read ambient conditions (i.e. temperature, humidity and pressure) from external sensors and enter them manually both before and after calibration.
Start-up weighing cycles quantity	Option allowing test run of the balance mechanism prior to performance of the calibration procedure. After providing a respective quantity value, the robot, prior to calibration procedure start, will place each probe on the weighing pan as many times as indicated by the parameter.
Print intermediate results	Printing every measurement result after confirming it during

in real time	pipette calibration procedure
Maximum cycle fill count	Vial filling level in the automatic device if you calibrate a single-channel pipette.
Tare mode	SINGLE mass value saved to the balance memory on a single pressing of the TARE key. Subsequent pressing of the TARE key determines a new tare value. Selecting a product or packaging to which a tare value is assigned causes the automatic deletion of the previously assigned tare value.
	CURRENT SUM total value of currently entered product and packaging tare values (result of selection of product and packaging from the database) with possibility to add tare value entered manually. When a new tare value for a product or packaging is set again, then the tare value entered manually gets deactivated.
	TOTAL SUM total value of all entered tare values
	AUTOTARE <u>Means of operation:</u> Each first stable measurement result is tared. The NET sign is displayed. Now you can determine the net mass of the weighed load. Upon unloading the weighing pan and autozeroing, the tare value is automatically deleted.
	EACH MEASUREMENT: possibility to tare prior to each measurement in the series
Automatic footer / C label printout	MODE <ul style="list-style-type: none"> • None – manual footer printout, • Sum of measurements – footer is printed when mass value entered in <Threshold> parameter gets exceeded. • Measurements quantity – footer is printed when a pre-defined measurements quantity (a batch) set in parameter <Threshold> is carried out.
	THRESHOLD – setting the threshold value determining footer printout. For <Sum of measurements> parameter, threshold value is determined in measuring unit [g], for <Measurements quantity> parameter the unit is not determined; the provided value specifies carried-out measurements

	quantity.
Printout / Enter mode	<p>PRINT/RELEASE BUTTON (manual activation after pressing )</p> <ul style="list-style-type: none"> • Never – printout disabled. • First stable – first stable measurement is recorded. • Each stable – all stable measurements are recorded. • Each – printout of all measurements (stable and unstable), for verified balance, only stable measurements are printed out (as in <Each stable> setting).
	<p>AUTOMATIC MODE</p> <ul style="list-style-type: none"> • None – printout disabled. • First stable - first stable measurement is recorded upon loading of the weighing pan with a load; the recording of the next stable measurement result takes place only if the following conditions are met: the weighing pan gets unloaded, measurement value lower than the value of the set threshold is displayed, a new load is placed on the weighing pan. • Last stable - last stable measurement, registered prior to unloading, is recorded. The record takes place only if the following conditions are met: weighing pan gets unloaded, measurement value lower than the value of the set threshold is displayed. • With interval – select this value to start the automatic printout and recording of indications to the WEIGHINGS database, carried out periodically at a predetermined time interval. The interval is set in [min] in <INTERVAL> parameter. The interval range is 1 s - 9 h 59 min 59 s. <p>Caution: <i>Each weighing result is printed and recorded (stable and unstable for a non-verified balance; stable for a verified balance).</i></p> <p><i>Automatic operation with an interval starts at the moment of switching the function on. The first stable weighing result of a value greater than the THRESHOLD value is printed and recorded as the first measurement. The following measurements are printed with the frequency set in the</i></p>

	<p><i>INTERVAL</i> parameter. To stop the automatic operation with the interval, switch the option off.</p> <ul style="list-style-type: none"> • Buffered – mode used for automatic pipette calibration. After choosing this option, set the following parameters too: STABILIZATION TIME AND MEASUREMENT TIME (description below). <p>THRESHOLD Mass value obligatory for operation of automatic printout, set in grams.</p> <p>INTERVAL Record frequency for automatic operation with an interval</p> <p>STABILIZATION TIME Time until measurement result collection starts, together with automatic operation with a buffer</p> <p>MEASUREMENT TIME Time of collecting measurement results used to determine the final value of the measurement</p> <p>PRINT REPORT Option allowing activation/deactivation of the automatic report printout after the end of the pipette calibration</p> <p>PRINT INTERMEDIATE IN REAL TIME Option allowing activation/deactivation of automatic printout of each partial measurement during the pipette calibration</p>
Statistics	<p>settings for statistical calculation during operation. Options:</p> <ul style="list-style-type: none"> • Global: statistical calculations are performed for all successive measurements, regardless of the selected product. • Product: statistical calculations are performed for particular products.

14.3. Pipettes Calibration – Quick Access Buttons

Each working mode features an automatically displayed set of default on-screen quick access buttons. The set can be modified, i.e. you can add out-of-list quick access buttons to it. Such operation requires particular permission level.

14.4. Adding a Pipette to Pipettes Database

The database of pipettes contains a list of pipette names and other data, including tested volumes and error values for a specific volume. When adding a pipette to the database, first specify its name, and then add the remaining data.

The software is intuitive, and you are guided by way of respective messages. The Pipettes database menu has been designed to enable adding formulations.

Procedure:

- Enter the <Databases> submenu and press the <Pipettes> button.



- Press the < Add> button to add a new pipette.

A new record is automatically added to the database, and it is opened in an editing mode. Enter the respective data.

A list of parameters defined for a pipette:



1. Name: press to enter pipette name.
2. Code: press to enter pipette code.
3. Model: press to enter model name.
4. Tip: press to enter tip name
5. Volume type: ADJUSTABLE/FIXED.
6. Nominal volume: pipette's nominal volume value.
7. Minimum volume: pipette's minimum volume value, for a fixed-volume pipette enter <0>;
8. Channels quantity: specify the number of pipette's channels, for a single channel pipette enter <1>;
9. Type: NONE/A/D1/D2. The pipette type adheres to standard guidelines. In the case of calibration carried out with reference to the ISO 8655 standard, the errors are automatically selected for a particular volume. Determining pipette type is crucial.
10. Tested volumes: press the "Tested volumes" field, a window with a list of calibrated volumes opens (in the case of a new pipette, the list is empty).Add

volume to be tested, and define the error value for each tested volume:
Procedure:

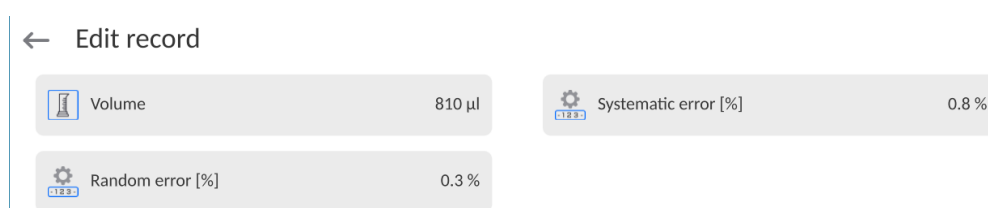
- Press the <  Add > button.
- An on-screen keyboard is displayed.
- Enter the tested volume value in [μl] and press the <  > button to confirm,
- A new record is automatically added. The record features recommended error values.
- In order to change error values, press a field with pipette volume



← Edit record

 Volume	810 μl	 Systematic error [%]	0.8 %
 Random error [%]	0.3 %		

- each field can be edited; you can enter error values of your choice.

Caution: During calibration, the order of tested volumes corresponds to the order in which they are entered.

- Upon setting correct values, return to the home screen.

14.5. Printing Reports from the Balance

The printout option enables you to determine the content of a particular standard printout and to define a non-standard printout.

- **Standard printout** comprises four internal blocks, each containing different variables. Variable settings: YES - print; NO - do not print.

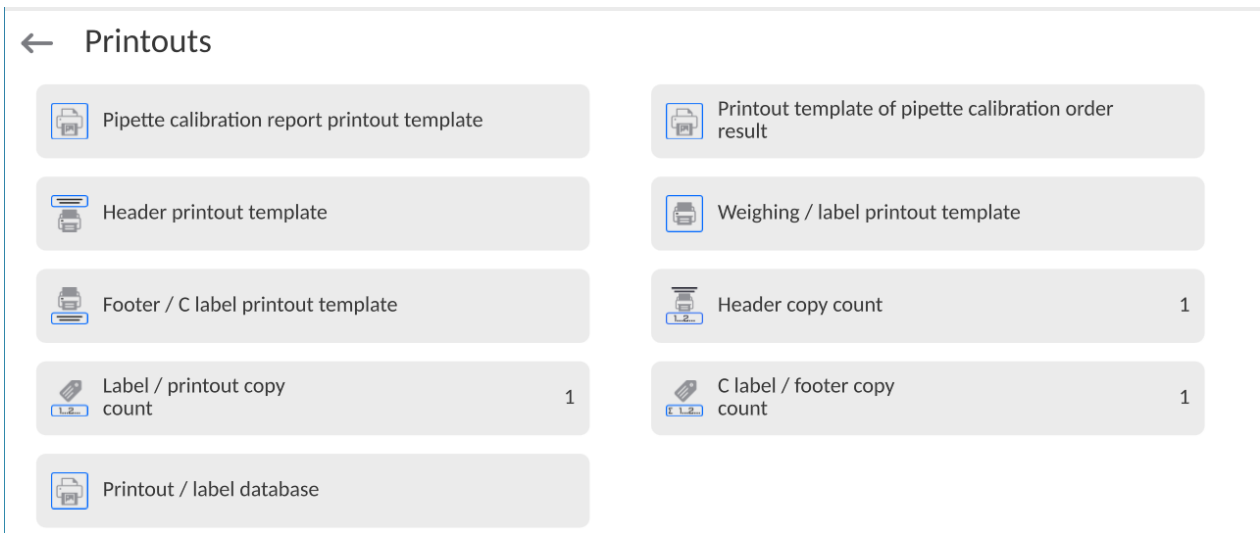

Settings for header, GLP, and footer printouts are specified in section 12.5. For settings of the pipette calibration report, read below.

Report content:

<ul style="list-style-type: none"> - Working mode - Operator - Name and Surname - Customer - Pipette - Serial No. - Channels quantity - Channel number 	<ul style="list-style-type: none"> - Measurement quantity - Operation with adherence ISO 8655 - Start date - End date - Water temperature - Temperature - Humidity 	<ul style="list-style-type: none"> - Pressure - Z coefficient - Measurements and statistics - Statistics - Status - Empty line - Dashes - Signature - Non-standard printout
--	---	--

Content of pipette calibration order result report:

<ul style="list-style-type: none"> - Working mode - Operator - Name and Surname - Order number - Start date - End date - Customer 	<ul style="list-style-type: none"> - Applicant - Pipette - Serial No. - Channels quantity - Measurements quantity - Status 	<ul style="list-style-type: none"> - Result - Remarks - Dashes - Raprts - Empty line Dashes - Signature - Non-standard printout
--	--	--

14.6. Pipette Calibration Using the Robot

Upon selection of either pipette or order for realization, the procedure will be performed automatically in accordance with messages displayed.

Keep in mind that prior to the calibration, test run will proceed as many times as set in <Test run cycle quantity> parameter.

Prior to the start and after completion of the calibration process, enter correct ambient conditions values indicated by the ambient conditions module.

14.7. Pipette calibration with use of the automatic system.





Before you initiate calibration, enter data of the pipettes that are to be calibrated, together with all data and errors (Pipette base) as well as calibration orders.

Another step is to set main options for the procedure.

Note: The description of options and their setting can be found in the point 14.2 of the manual.

After setting the aforementioned options, you can go the pipette calibration procedure.

To perform calibration, follow the steps below:

1. Press < Select order>.
2. Select the desired order from the list of orders.
3. After selecting the order, the program will return to the home screen and the info field will show the pipette name from the order.
4. Press < Start> in the lower bar.
5. If <Ask about series number> option has been set as <YES>, a window will open. In the window, you need to enter the name and confirm your choice.
6. Then another window will pop up. There, you have to enter particular values read from external sensors (temperature, humidity, pressure and water temperature) and press < Confirm>.
If <Download environmental conditions from THB> option has been set as <YES>, the program will automatically download values from the THB module for the temperature, humidity and air pressure. Enter the water temperature value and press < Confirm>.
7. Next, the program will automatically perform the transport cart test run through all positions and make it return to the base position, which will be communicated to the operator through relevant messages.

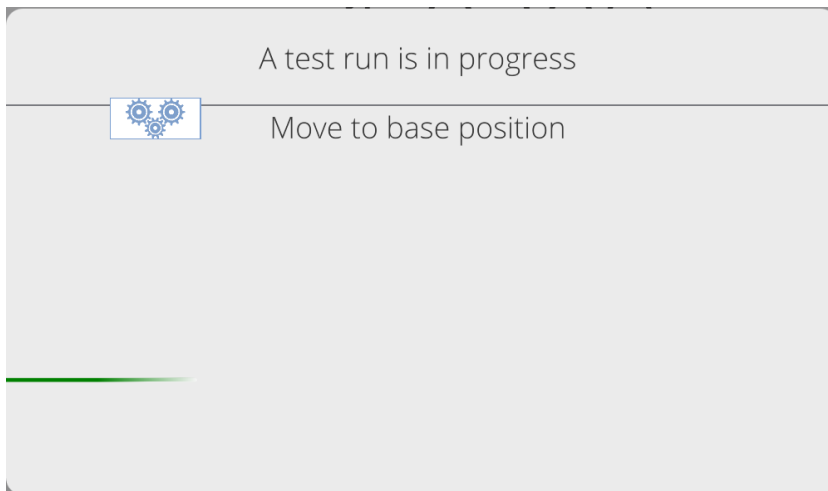

8. Another step is to tare the mass of particular vials to which a liquid will be dosed from the calibrated pipette (relevant messages are displayed on the balance).

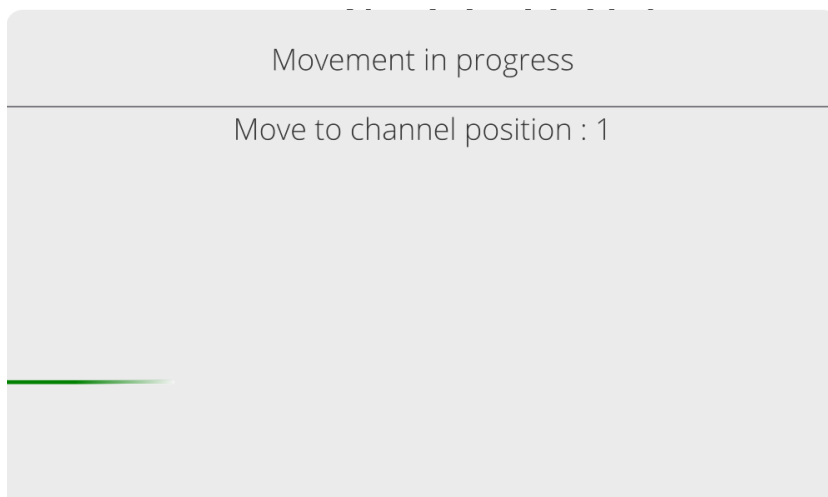

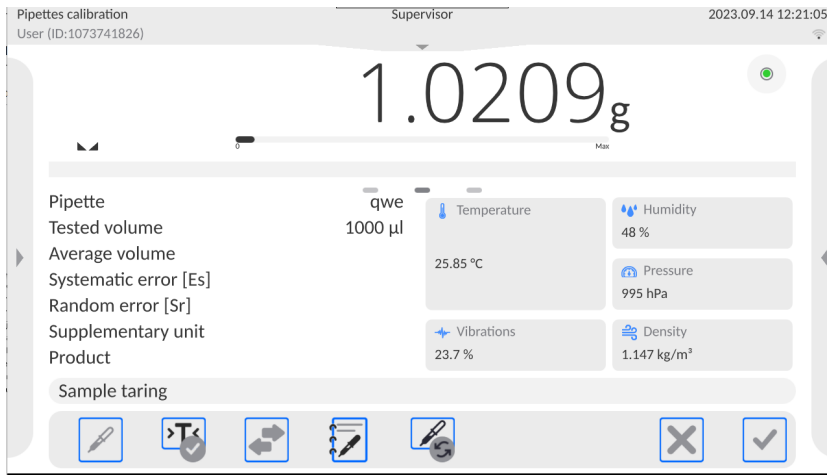

9. When vial tarring is finished, the transport cart will return to the base position and the operator will be informed through a message about which vials must be filled up by dosing a suitable amount of liquid from the calibrated pipette.

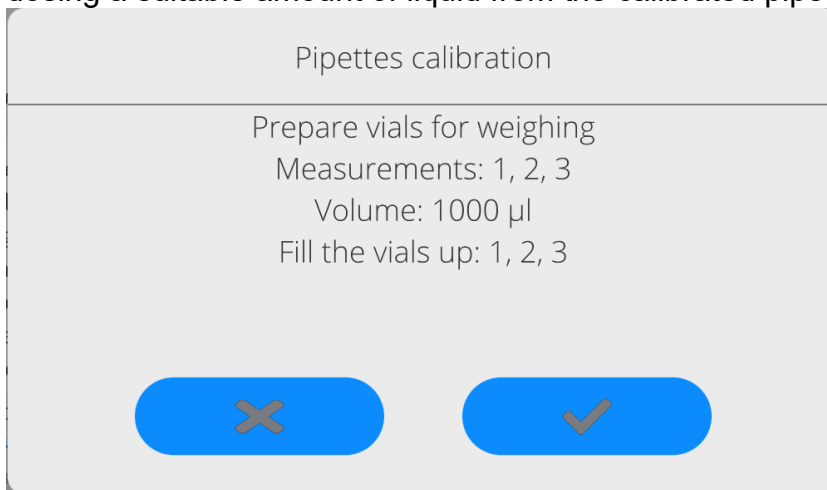

10. After filling vials up and confirming the operation, the transport cart will go into particular positions and the measurement will be automatically saved as per the settings of the PRINTOUT/CONFIRMATION MODE parameter. Please remember that the following settings are recommended from the automatic operation of the balance with an accuracy of $d=0.01$ mg: PRINTOUT/CONFIRMATION KEY – NEVER; AUTOMATIC MODE – WITH BUFFER; STABILISATION TIME – 2s; MEASURING TIME – 3s.

If the operator wants to save particular measurements manually, he must set the following values for the above-stated parameters: PRINTOUT/CONFIRMATION KEY – EVERY STABLE; AUTOMATIC MODE – NEVER. For these settings, when the

transport cart stops in the position, confirm the measurement by pressing if the displayed result has stabilised.

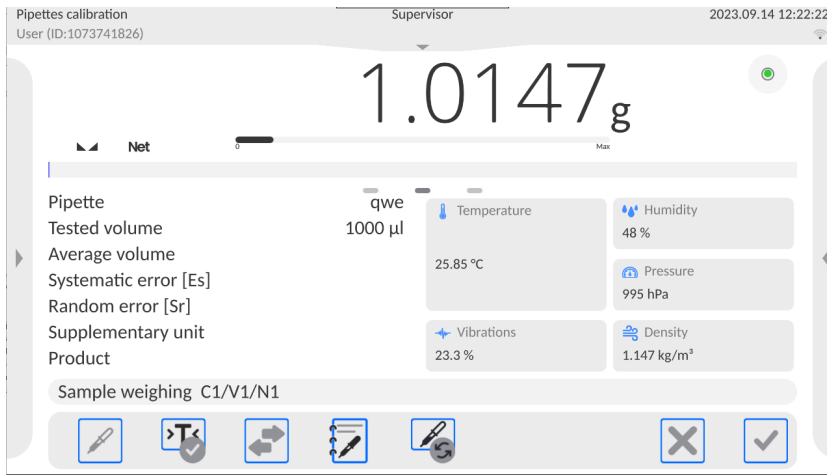

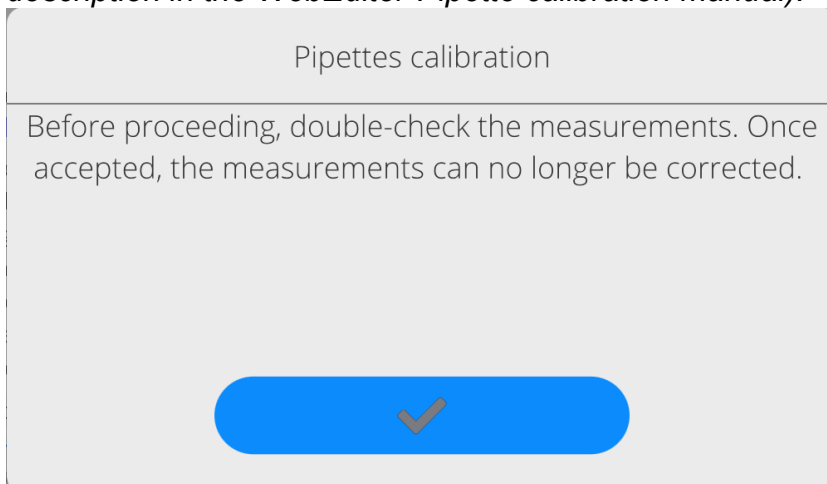

11. After all measurements for a specific order have been completed, a message will be displayed to inform the operator about a need to make sure measurements are correct. This step can be taken from the level: WebEditor – Pipette calibration (see *description in the WebEditor-Pipette calibration manual*).

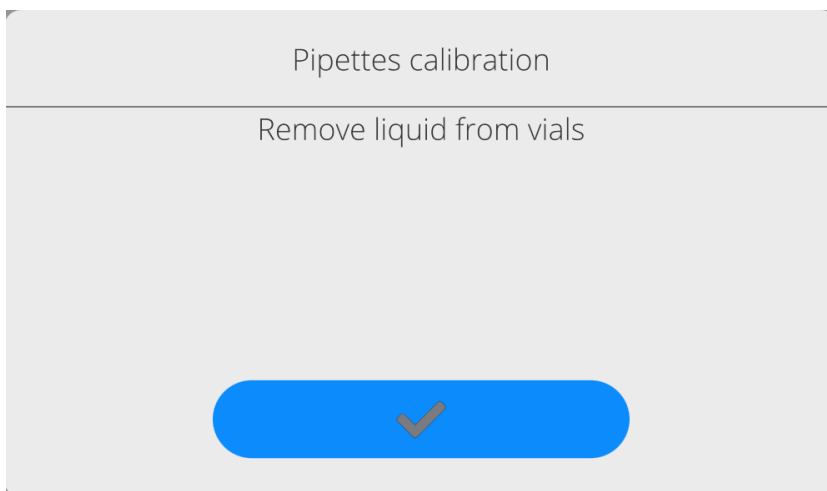

12. After checking measurements and confirming them via , the vial emptying reminder message will be displayed.



13. Press  to confirm the above and you will see a window with environmental conditions data. Do as at the beginning of the procedure, that is enter all parameters and press  Confirm>.
14. The program will automatically generate the report which will be printed out and saved in the pipette calibration report base (values for environmental conditions and water temperature that can be found in the report are average initial and final values for the procedure).
15. Press  in the lower bar to finish the procedure. With regard to a multi-channel pipette, you will see a message with a question whether you wish to continue the procedure for next channels. Confirm to initiate the procedure for another channel as per previous assumptions.

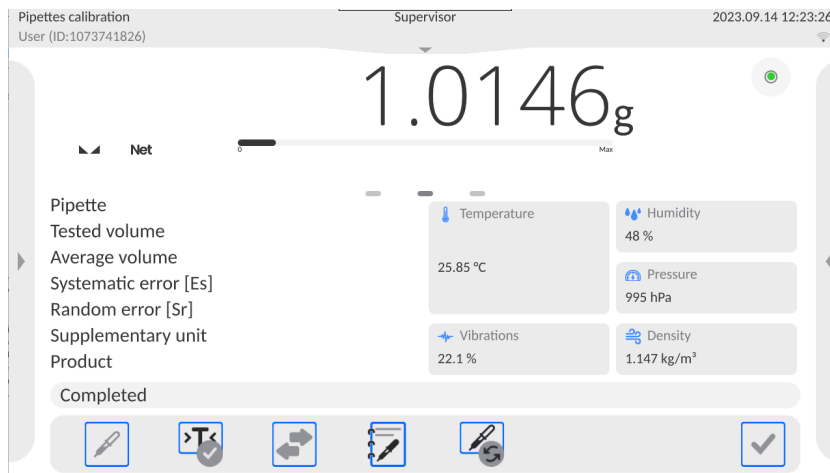

16. You can start another pipette calibration procedure.

14.8. Performed Pipette Calibrations Report

Upon completing the calibration process, a report is generated. The report is saved to the <Pipette calibration reports> database. The files are named by the date and time (hour) of the calibration process performance.

Report example:

----- Pipettes Calibration -----		
Operator	Kowalski	
Customer	Nowak	
Pipette	p901\1k	
Serial no.	7777	
Channels quantity	1	
Channel no.	1	
Measurements quantity	10	
Operation with adherence to ISO 8655	Yes	
Start date	2012.03.15 07:50:44	
End date	2012.03.15 07:54:34	
Water temperature	22.15 °C	
Temperature	21 °C	
Humidity	48 %	
Pressure	1005 h Pa	
Z coefficient	1.00328	
----- Tested volume: 1000 µl -----		
1	0.998 g	1000.82389 µl
2	0.998 g	1000.82389 µl
.		
Average volume	1000.82389 µl	
Average [%]	100.08 %	
Systematic error	0.82389 µl	
Systematic error [%]	0.08239 %	
Permissible error	± 16 µl	
Random error	0 µl	
Random error [%]	0 %	
Permissible error	± 6 µl	
Status	Positive	

Signature	

15. DATABASES

The balance features the following databases:

← Database



Operators



Products



Customers



Formulations



Pipettes



Packaging



Warehouses



Printouts / Labels



Series



Universal variables



Manage the
database

NOTE: description of databases that are not included in this manual can be found in the standard 5Y balance user manual.

15.1. Database Operations

Databases can be operated only by an authorized personnel.

Procedure:

- Press and hold a respective database pictogram.
- Database menu is displayed.
- Select one of the available entries (entries set is conditioned by a database).

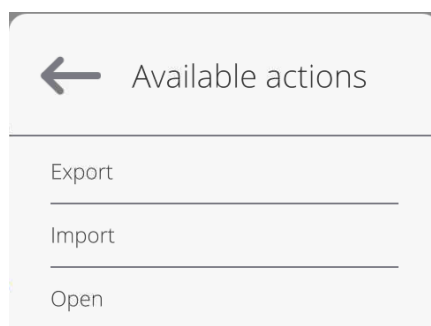

Entries:

- **EXPORT** - select to export data from a selected database to a USB flash drive. Plug the USB flash drive to a USB port; upon its detection, the software automatically starts a copying process. Upon completion of the copying process, a window with

both, a file name to which data have been saved and message: <Completed> is displayed. Confirm completion.

- IMPORT – select to import data from a USB flash drive. Plug the USB flash drive to a USB port; upon its detection, a window with a list of saved files is displayed. Select file with data to be imported. The copying starts automatically. Upon completion of the process, message: <Completed> is displayed. Confirm completion.
- OPEN – select to enter a database (alternative method for database entering: single click on a given database field).

List of typical database operations:

1. Adding entry to a database.
2. Searching for a record in a database by name.
3. Searching for a record in a database by code.
4. Searching for a record in a database by date.
5. Exporting database content to a USB flash drive via USB port.
6. Printing data on a specific record in a database.

The above processes are initiated by dedicated buttons located on the top of the display. Follow the displayed commands.

15.2. PERATORS

Operators database features list of users permissioned to operate the balance.

The following data can be defined for each balance operator:

Name	Code
Password	Name and Surname
Permissions	Active account
Language	Default profile
Card number	Fingerprint (<i>parameter visible only after connecting the fingerprint scanner</i>)
Face profil	Theme

CAUTION: Only a user with Administrator status can add new operators or delete operators from the database.

NOTE: You can also add an operator in the application: Radweg Web Editor - pipette calibration

In order to add an operator:

- Enter <Operators> menu, press <  > button.
- Define all necessary data.

Caution: It is possible to search for an operator in a database of operators by code or name.

Log in using a transponder card:

Caution: The RFID reader mounted in the indicator operates at a frequency of 13.56MHz and complies with ISO/IEC 14443 Type A.

Only cards of this standard will be recognised by the reader.

- Enter Operator settings.
 - Select <Card no.>

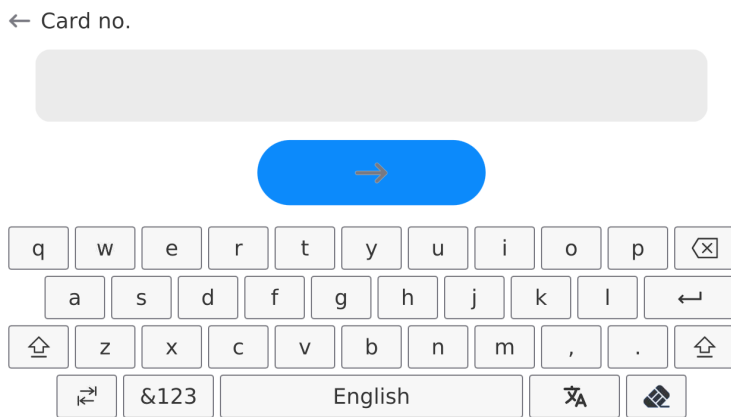

- Apply the card to the RFID reader.
 - The card number is automatically entered in the editing field.

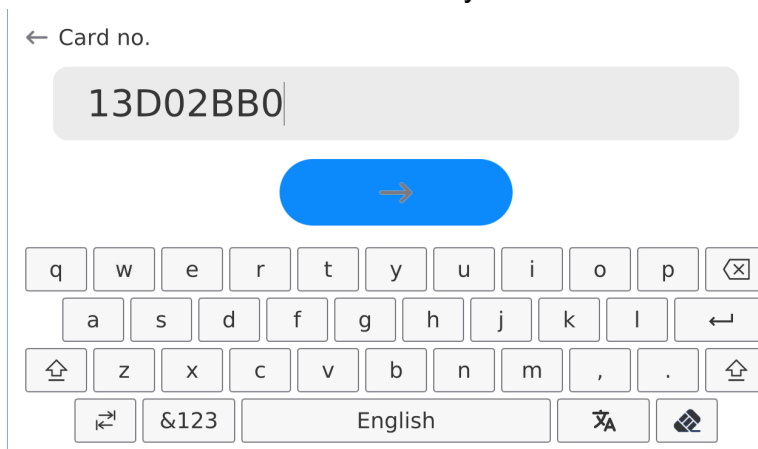

- Press  button, the card number is added to the operator settings.

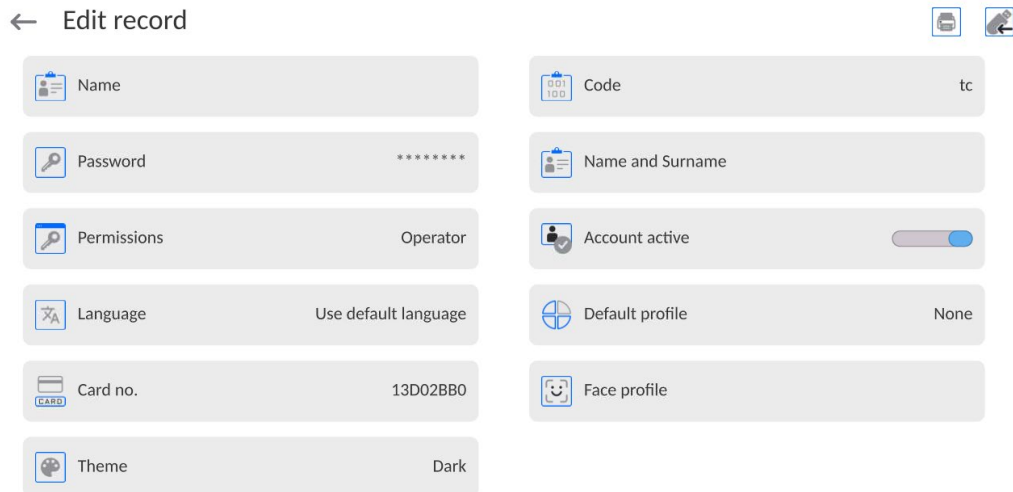

- Exit to the home screen. From now on, applying this card to the RFID reader will automatically log the user in.

Log in using a fingerprint:

Caution: Only the fingerprint reader listed as a dedicated accessory for these balances can be connected to the balance. A list of accessories can be found on RADWAG website.

- When the fingerprint reader is connected to the USB type A socket, the <Fingerprint> option appears in the operator settings menu.

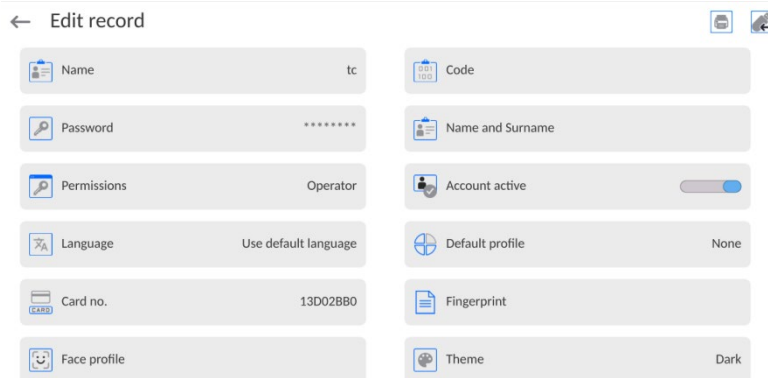

- To add a fingerprint for an operator, enter this option.

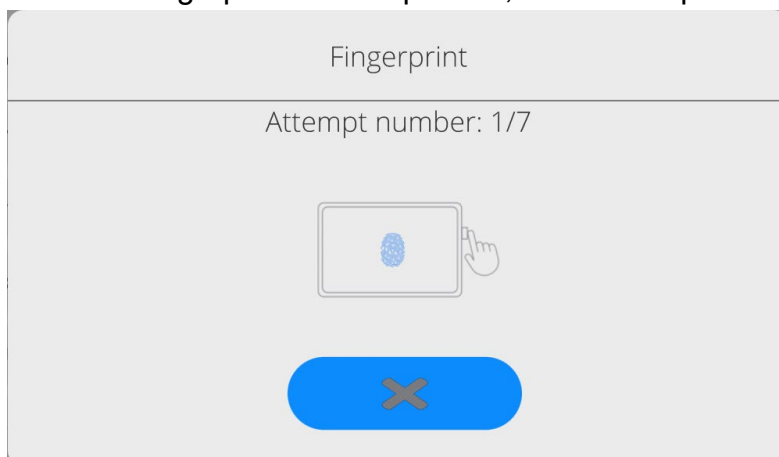

- Scan the fingerprint and repeat the procedure 7 times (as described in the message box).
- When the procedure is completed correctly, a summary window is displayed.

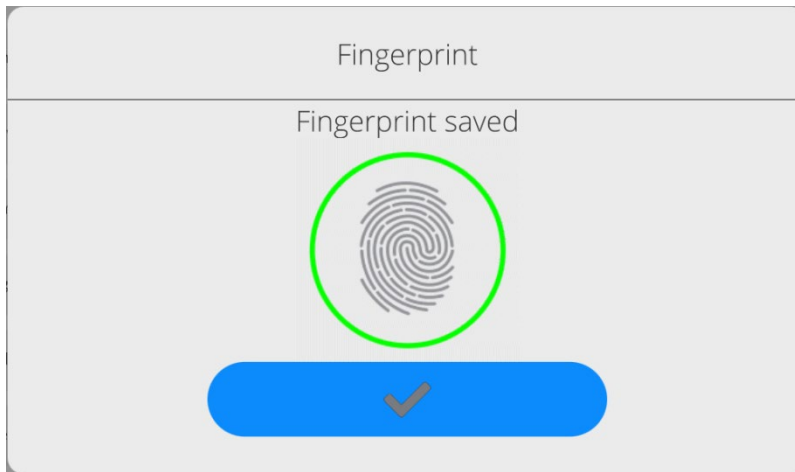

- Confirm the procedure by pressing  button.
- From now on, if a fingerprint reader is connected to the USB port, a pictogram of the active fingerprint login option is displayed in the login window.

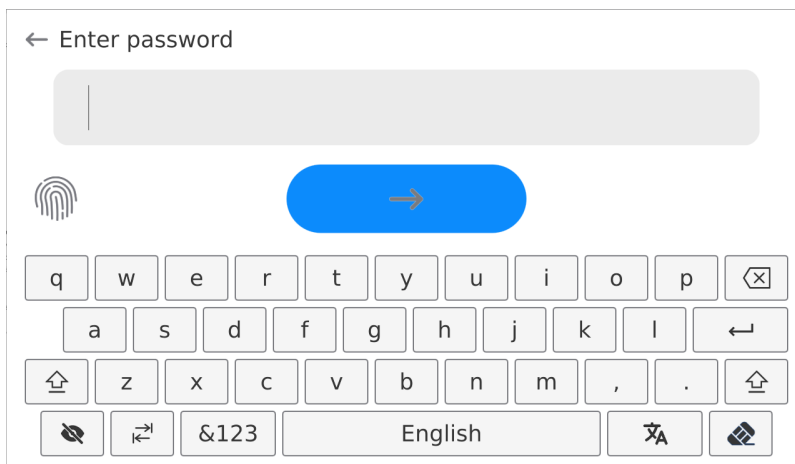

- After placing a finger on the reader and confirming the correctness of the fingerprint with the stored pattern, the pictogram briefly turns green, the user is automatically logged in, and the software switches to the home screen. The name of the logged-in user is displayed in the top bar of the window.
- If the scanned fingerprint does not match the stored pattern, the pictogram briefly turns red, the user is not logged in, and the software displays the login window.

Log in using a face profile:

- To add a face profile for a user, go to the option presented below

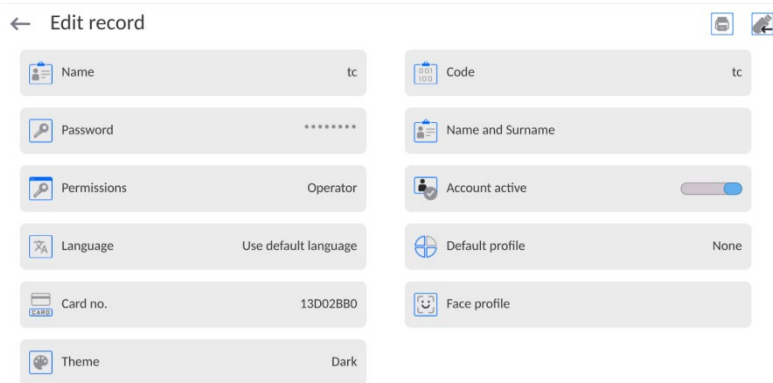

The screenshot shows a mobile application interface for editing a user record. At the top, there is a back arrow and the text 'Edit record'. Below this, there are several input fields and controls arranged in two columns. The left column includes: 'Name' (value: tc), 'Password' (masked with dots), 'Permissions' (value: Operator), 'Language' (value: Use default language), 'Card no.' (value: 13D02BB0), and 'Theme' (value: Dark). The right column includes: 'Code' (value: tc), 'Name and Surname', 'Account active' (toggle switch), 'Default profile' (value: None), and 'Face profile' (button with a face icon). There are also small icons for deleting and refreshing at the top right.

- After starting the option, a message is displayed and the face profile is read; you must position yourself correctly in relation to the camera so that the program can save the profile.

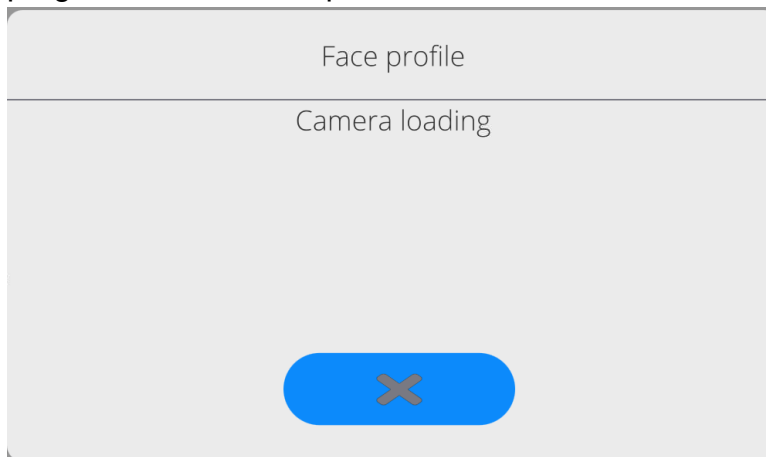

- Once the profile has been saved, a message is displayed along with a picture from the camera.

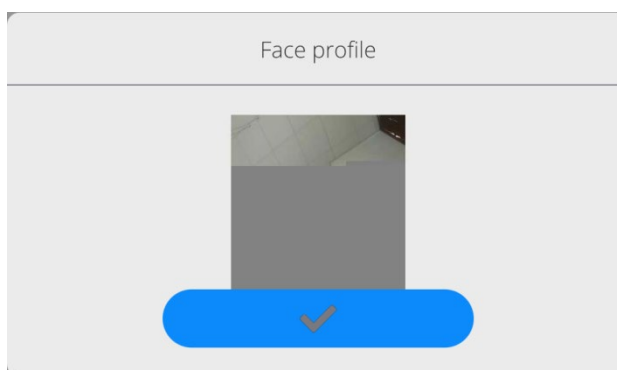

- Press  button to close the window.

- The option description in the user settings changes to <Delete face profile>, indicating that the profile is stored in the balance memory.

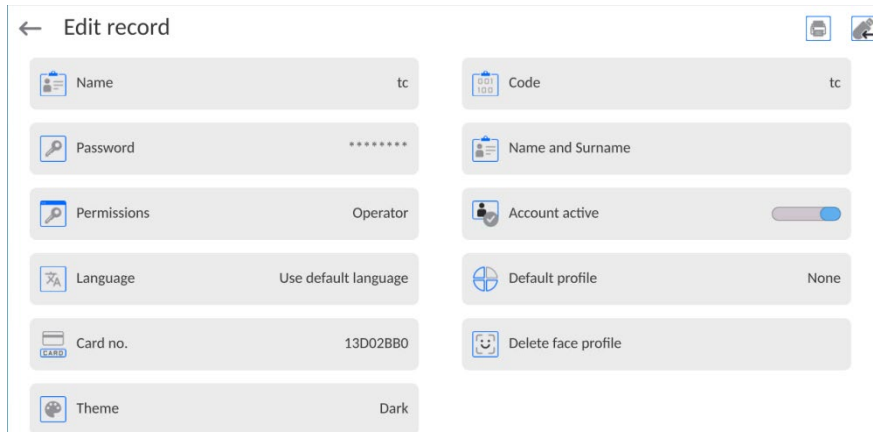

- From now on, if the user for whom the face profile was added logs in, after entering the logging window, the program will automatically read the profile, which will be signalled by the pictogram on the left side of the window

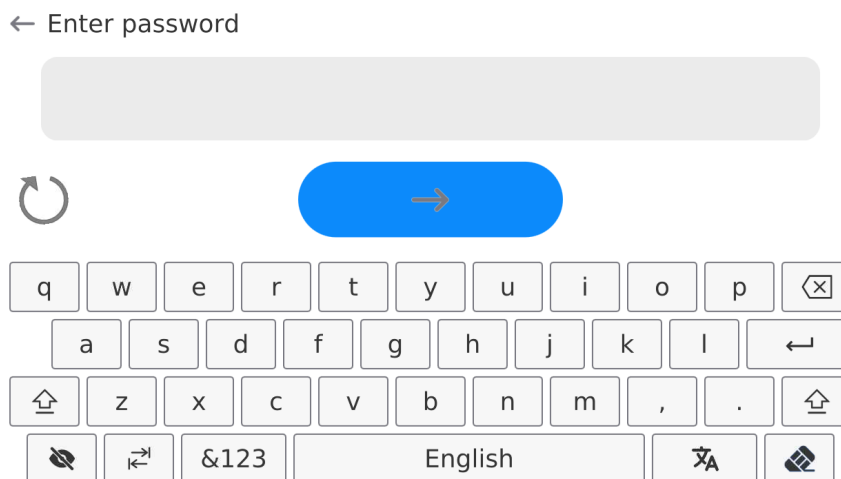

- The program automatically reads a photo of the user's face profile, and after the photo is read, the camera turns on (which is indicated by the lighting of a diode next to the camera) and compares the saved photo with the profile read by the camera. If these images match, the main program window will open and the name of the logged-in user is displayed in the top bar of the window.

Editing data on an operator:

- Press field with operator name.
- Data on a specific operator is displayed.
- Select and change necessary data.

To delete an operator:

- Press and hold operator name.
- Database menu is displayed.

- Select <Delete> parameter and confirm.

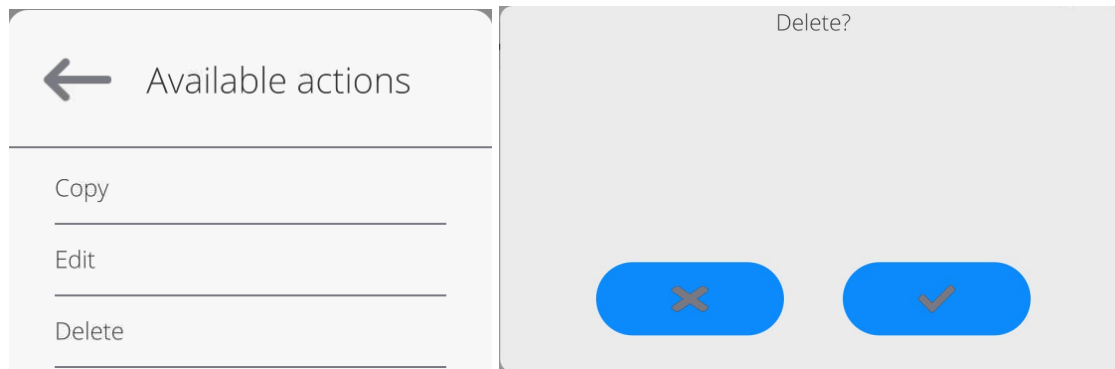

15.3. Customers

Customers database contains name of Customers for whom the measurements are carried out.

Procedure:

- Enter <Databases> submenu and press <Customers> entry.
- Press <Add> button.
- Select the already existing customer.

List of parameters defined for a customer:

1. Customer name
2. Customer code [internal code identifying a customer]
3. TIN
4. Address
5. Postal code
6. City
7. Discount
8. Printout [type of printout, customer-related label]

NOTE: You can also add a customer in the application: Radweg Web Editor - pipette calibration

15.4. Pipettes

Pipettes database contains data of pipettes that are to be calibrated.

Procedure:

- Enter <Databases> submenu and press <Pipettes> entry.

- Press <Add> button to add a new pipette, or
- Select the already existing pipette.

List of parameters defined for pipettes:

1. Name
2. Code
3. Model
4. Tip
5. Volume type
6. Nominal volume
7. Minimum volume
8. Channels quantity
9. Type
10. Tested volumes

NOTE: You can also add a pipette in the application: Radwag Web Editor - pipette calibration

15.5. Pipette calibration order database

The pipette calibration order database includes saved calibration orders for particular customers. In this database, you can preview the order status and if the order has been completed - the calibration report. The report can also be exported into the pendrive connected to the USB port.

Procedure:

- Enter <Databases> submenu and press <Pipette calibration order database> field.
- Press <Add> button if a new packaging is to be added.
- If the pipette calibration order already exists, press the name field, enter information related to the pipette calibration order.

NOTE: You can also add the order in the application: Radwag Web Editor - pipette calibration.

15.6. Warehouses

Depending on the organization of work, the warehouses database contains a list of places used for picking up a sample for weighing or a list of places to which a weighed sample was delivered. Each warehouse has to have its name, code and description specified. During the weighing process, and upon selecting the name of a warehouse, it is automatically assigned to the measurement result.

Procedure:

- Enter <Databases> submenu and press <Warehouses> entry.
- Press <Add> button to add a new warehouse, or
- Select the already existing warehouse.

Caution: *It is possible to use 'search record' option, you can search by name or by code.*

15.7. Printouts / Labels

Printouts database contains all NON-STANDARD printouts. Each printout features a name, code and a template.

Procedure:

- Enter <Databases> submenu and press <Printouts> entry.
- Press <Add> button to add a new printout, or
- Select the already existing record.

Caution: *It is possible to use 'search record' option; you can search by name or by code.*

Designing new printout template

Procedure:

- Enter <Databases> submenu and press <Printouts> entry.
- Press <Add> button to create a new printout, or edit the already existing one.

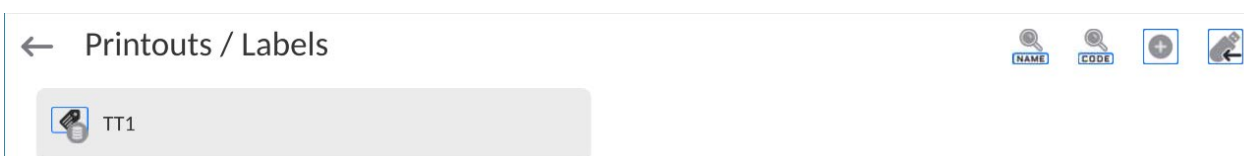

- Edit box opens, press <Project> entry.
- Respective box with an on-screen keyboard is displayed.
- To design a printout, you can use an external USB keyboard connected to the head or a touch keypad that has the same functions as a typical PC keyboard.

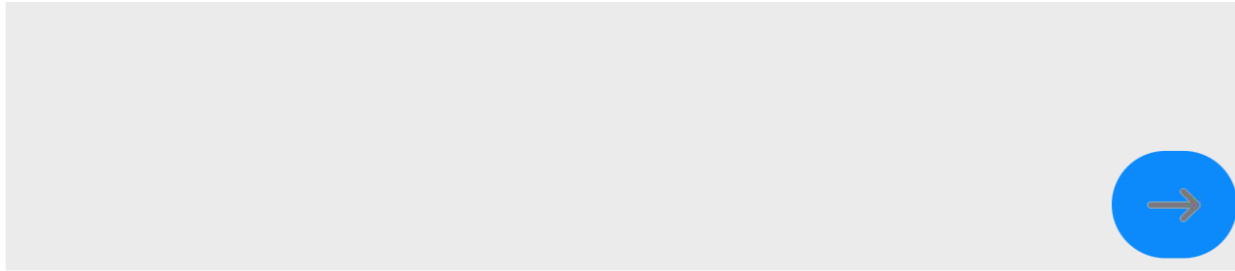

The touch keypad does not have some characters, such as a colon or diacritical letters typical of a specific menu language (menu language is signalled with description on ‘SPACE’ key). To use such characters or letters in the designed printout, press and hold the specific letter on the keyboard. It will cause additional keys with assigned characters to display. Click them to add to text. After entering the character, press ‘X’ to disable displayed characters.

The example of available characters for Polish keyboard.

Letter on the keyboard	Additional characters	Letter on the keyboard	Additional characters	Letter on the keyboard	Additional characters
„t”	€ ✕ t y	„u”	µ ✕ u i	„a”	~ ✕ a s
„x”	’ ` ✕ x c	„c”	\ ✕ c v	„v”	[{ ✕ v b
„b”] } ✕ b n l	„”	: < = ✕ , . ↵	„”	; > ✕ . ↵

- Save the designed printout.

Example of Printout no. 1 – large edit box

← Project

BALANCE NO: {32}
 Max=220 g
 d={33}

PRODUCT: {50}
 DATE: {2}
 TIME: {3}

WORKING MODE: {5}

Balance no. 400015
 Balance parameters:
 Max = 220 g
 d= 0.001 g

Product name:
 Date: 2011.10.24
 Time: 11:48:06

Working mode: Weighing

Net weight: 94.147

Carried out by: Admin

Project





Printout template

Example of Printout no. 2 – printout from a file

All printout templates can be designed in a form of external files, that are imported to a balance; file extension: *.txt or *.lb. External file shall contain all constant and variable data. Upon importing, the content of a printout template can be modified.

Procedure:

- Design a *.txt or *.lb file in an optional editor.
- Copy the file to a USB flash drive.
- Connect the USB flash drive to the balance USB port.
- Press [4] <  Download a printout from a file> button,
- Balance display shows data stored on the USB flash drive connected to the USB port.
- Select file with a printout template and press its name.
- The printout template is automatically copied to an editing field.

	<i>The user may add printouts from external memory via import of already configured texts, using USB port.</i>
	<i>Printout name is not the content of a printout.</i>
	<i>List of variables intended for printouts is to be found in 'ANNEX 03'.</i>
	<i>Example of how to create and send label template to the balance memory is to be found in 'ANNEX 03'.</i>

15.8. Universal Variables

Universal Variables are alphanumeric data which can be combined with printouts, products or other comparison-related information. Each variable has to have its name, code and value specified.

Procedure:

- Enter <Databases> submenu and press <Universal variables> entry.
- Press <Add> button to add new variable, or
- Select already existing universal variable, and modify the following fields: code, name, value.

Caution: It is possible to use 'search record' option; you can search by name or by code.

15.8. Databases Management

Function allowing to manage databases data. It comprises three options: Export weighing database, Delete databases and Delete weighings and reports.

← Manage the database

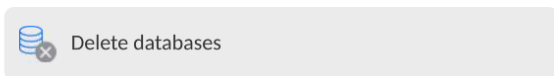

15.8.1. Delete Databases

Function allowing to delete data of selected database. Procedure
Activate <Delete database> function; a window with database list is displayed.
Select a database, delete respective data.

← Delete databases

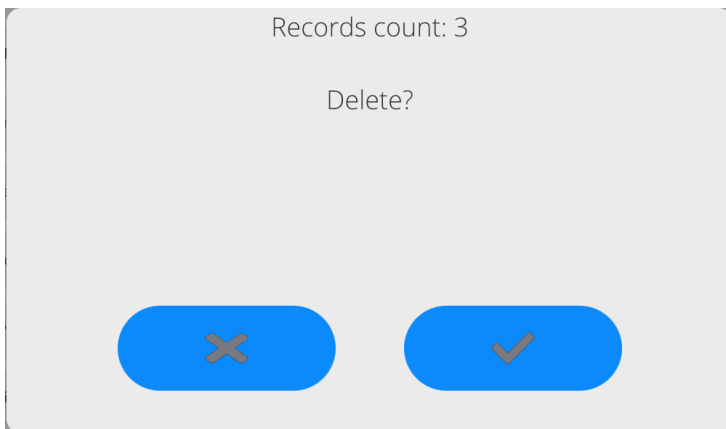
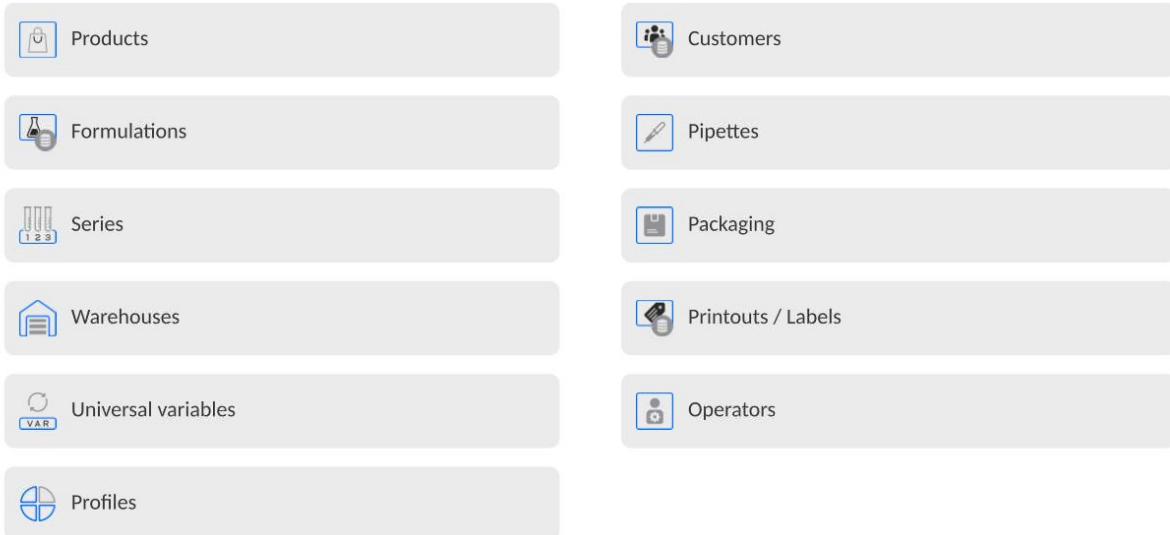

Confirm, data is deleted, the following message is displayed:

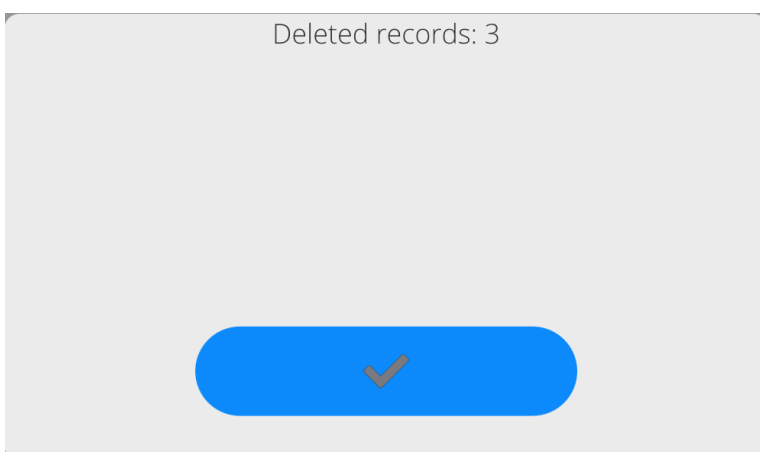

Confirm, a previous window is displayed; you may continue weighing or proceed to other operations.

16. REPORTS

The balance features the following reports:

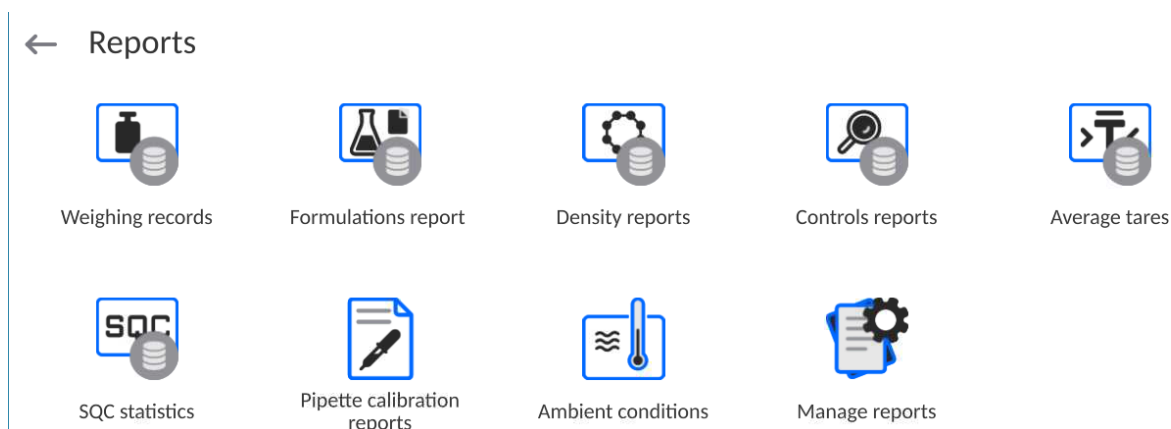

NOTE: description of report databases that are not included in this manual can be found in the standard 5Y balance user manual.

16.1. Reports Operations

Databases can be operated only by an authorized personnel.

Procedure:

- Press and hold a respective database pictogram.
- Database menu is displayed.
- Select one of the available entries (entries set is conditioned by a database).

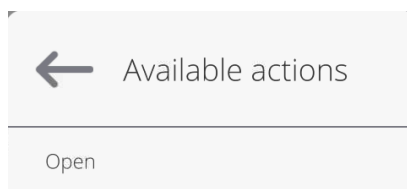

Entries:

- OPEN – select to enter a database (alternative method for database entering: single click on a given database field).

List of typical database operations:

1. Searching for a record in a database by name.
2. Searching for a record in a database by code.
3. Searching for a record in a database by date.
4. Exporting database content to a USB flash drive via USB port.
5. Printing data on a specific record in a database.

The above processes are initiated by dedicated buttons located on the top of the display. Follow the displayed commands.

16.2. Weighings

Each weighing result sent from the weighing device to a printer is saved to the weighings database (read section *Result control*).

You can preview data of particular weighing records.

Procedure:

- Enter **<Databases>** submenu.
- Enter **<Weighings/Alibii>** database and select desired record.

List of parameters defined for a weighing record:

1. Measurement date.
2. Measurement result.
3. Tare value.
4. Stable/unstable measurement marking.
5. Air buoyancy control on/off marking.
6. Product name.
7. Operator.
8. Customer, customer name.
9. Working mode name.
10. Warehouse, source warehouse name.
11. Packaging, name of tare applied during product weighing.
12. Result control, information regarding range within which the weighed product is placed:
MIN – below LOW threshold (possible only if <Result control> is set to <NO> value),
OK – between the LOW and HIGH thresholds,
MAX – above HIGH threshold (possible only if <Result control> is set to <NO> value).
13. Weighing platform no., field with number of a weighing instrument by means of which a measurement was carried out.
14. Level status, information on level status maintained during the measurement .
15. Ambient conditions alerts, information regarding stability of temperature and humidity during the measurement.

16.3. Pipette calibration order results

The contain information on order measurements. For every report, it is possible to preview, search by name, date, export and print out.

Procedure:

- Enter <Reports> submenu and press <Pipette calibration order results> field.
- Press the report field. If the report is not visible, scroll the list of reports using navigation keys.
- The report name consists of a name, date and creation time, e.g. 123456 2023.03.12 11:12:15

Information in the density report:

1. Name
2. Status
3. Result
4. Pipette
5. Serial number
6. Created
7. Ended
8. Customer
9. Petitioner
10. Test
11. Notes
12. Certificate no.
13. Certification date
14. Authorized
15. Authorize
16. Annotation
17. Channel 1.

16.4. Ambient Conditions

<Ambient conditions> database contains parameters related to ambient conditions. Depending on the balance type, the ambient conditions report can provide values of temperature, humidity, atmospheric pressure. If the given balance is connected to a THB sensor, then its indications are recorded to the database too.

Procedure:

- Enter <Databases> submenu and press <Ambient conditions> entry.
- Select report, if not visible, scroll using navigation buttons.
- Report is named by date and time.

Caution: It is possible to use 'search report' option.

16.5. Reports Management

Function allowing to manage databases data. It comprises three options: Export weighing database, Delete databases and Delete weighings and reports.

← Manage reports

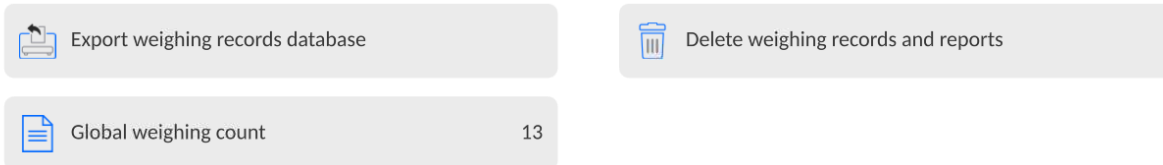

16.5.1. Export Weighing Database to a File

All measurements are saved to the <Weighing records> database and can be exported to a file using a USB flash drive.

Procedure:

- Connect the USB flash drive to the USB port.
- Press <Export weighing records database to a file> entry; a window for setting export options is opened.

← Export weighing records database

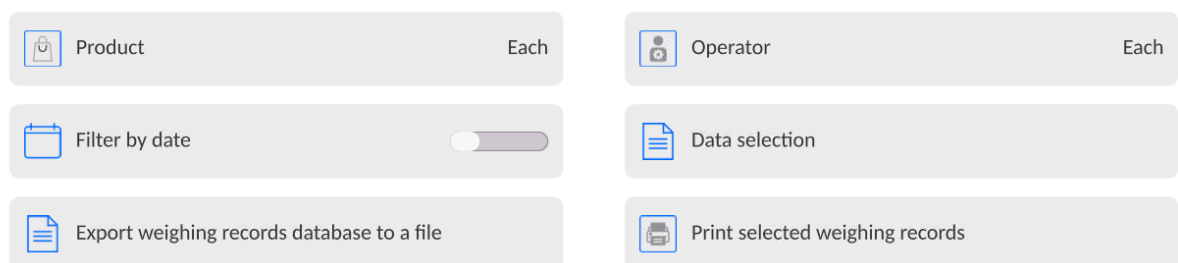

<Data selection> parameter allows you to specify which measurement-related data are to be exported.

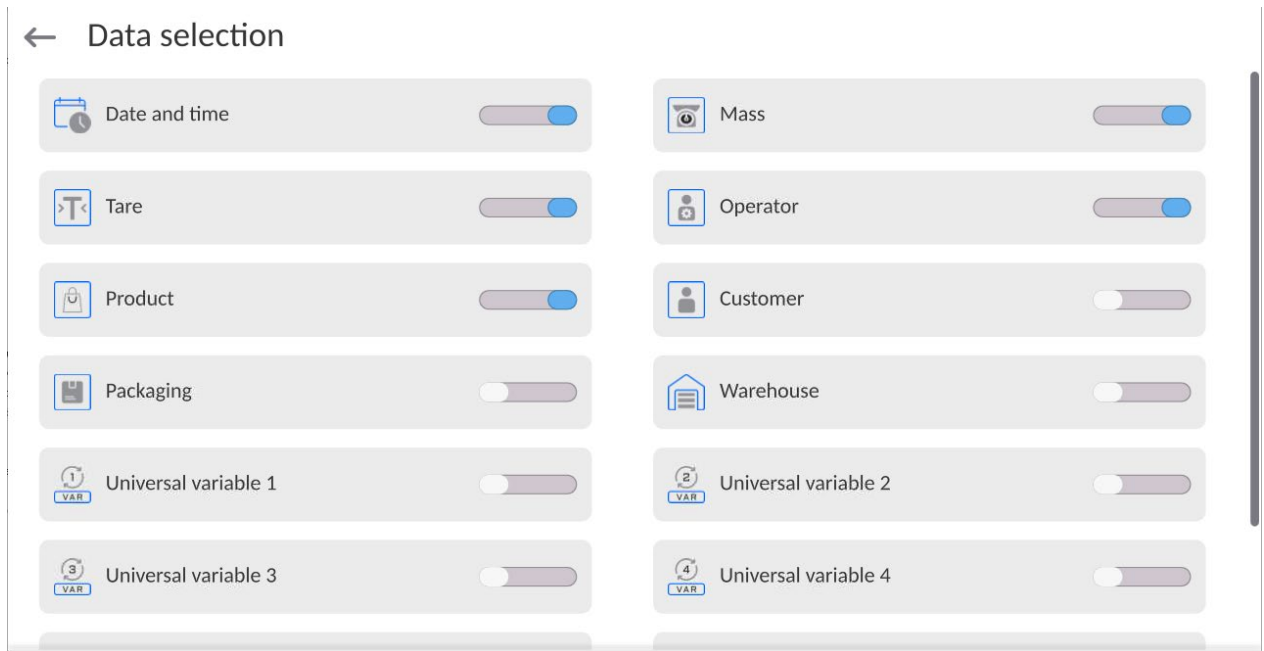

- Set respective data and press <Export weighing records database to a file> entry; weighing database is automatically exported.
- Upon export completion, the message <Completed> is displayed along with information on the number of exported data and with the file name (*.txt extension). Next, previous window is displayed.

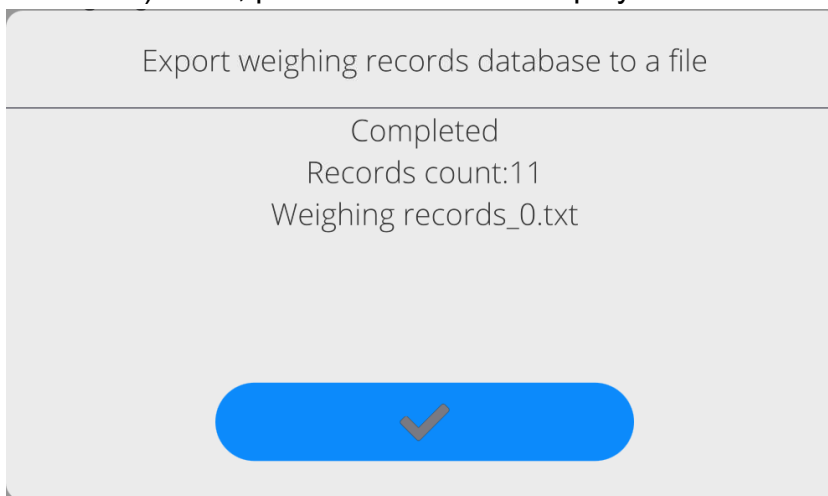

- You may return to the weighing procedure or proceed to other settings.

Caution: If balance software cannot identify the USB flash drive, then upon pressing <Export weighings database to a file> entry, <Operation failed> message is displayed.

- A name of created file consists of database name and balance serial number, e.g. <Weighing data_364080.txt>.
- Unplug the USB flash drive from the USB port.

Template of a created file:

The file is created in the form of a table, columns of which are separated by <Tab>. This allows for direct export of the file to <Excel> spreadsheet document. The table contains the following data: date and time, mass and mass unit, tare and tare unit, serial number, operator name, customer name, packaging name, source warehouse name, target warehouse name, control result name.

16.5.2. Delete Weighings and Reports

Function allowing to delete weighings and reports of a given database.

Procedure:

Activate <Delete weighing records and reports> parameter; a window with a numeric keyboard is displayed.

Enter a date specifying which data is to be removed. Date is given in the following form: year-month-day.

← Delete older than

16.03.2023

marzec 2023						
pon.	wt.	śr.	czw.	pt.	sob.	niedz.
27	28	1	2	3	4	5
6	7	8	9	10	11	12
13	14	15	16	17	18	19
20	21	22	23	24	25	26
27	28	29	30	31	1	2
3	4	5	6	7	8	9

→

Confirm the date, all weighings and reports older than those specified by the date are removed. Quantity of deleted weighings and reports is displayed.

17. COMMUNICATION

Communication menu is located in the Parameters menu. To access Parameters menu, press Setup key or <Setup> quick access button. Communication between the balance and the peripheral devices is established via the following ports:

← Communication

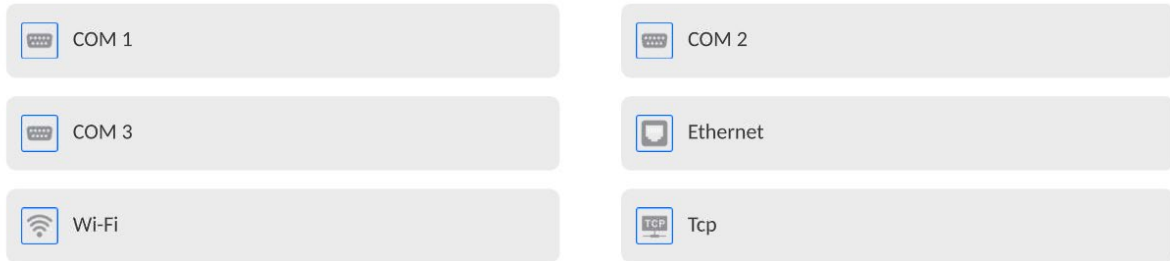

The parameters of each port can be configured depending on the needs.

17.1. RS232 Ports Settings

CAUTION: To ensure correct interaction with external devices via RS 232 ports, use a USB to RS232 converter.

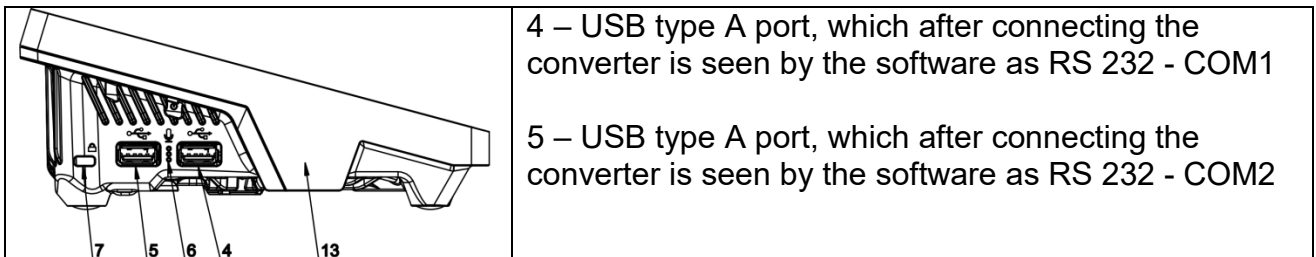

Procedure:

- Select communication port: <COM1> or <COM2>.
- Set respective parameters.

Transmission parameters for RS 232 ports:

- Baud rate: 4800, 9600, 19200, 38400, 57600, 115200 bit/s
- Data bits: 5, 6, 7, 8
- Stop bits: None, 1, 1.5, 2
- Parity: None, Odd, Even, Marker, Space

17.2. ETHERNET Port Settings

Procedure:

- Select <Ethernet> port. Set respective parameters:
- DHCP: Yes – No

- IP Address: 192.168.0.2
- Subnet mask: 255.255.255.0
- Default gate: 192.168.0.1

Caution: The above presented values serve informative purposes only. Set the transmission parameters in accordance with your local network.

Press  button, the message <Restart balance to implement changes> is displayed.

Return to the weighing procedure and restart the balance.

17.3. Wi-Fi Settings

A balance equipped with Wi-Fi displays a respective pictogram:

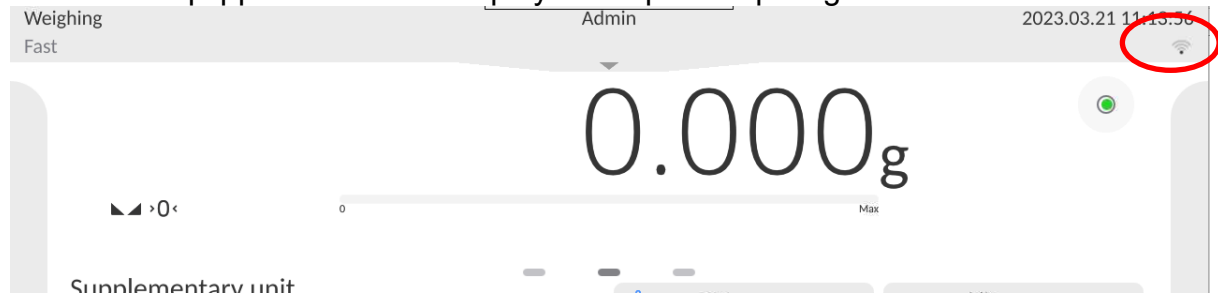

Procedure:

- Select <Wi-Fi> communication interface. Set respective parameters:
- DHCP: Yes – No
- IP Address: 10.10.9.155
- Subnet mask: 255.255.255.0
- Default gate: 10.10.8.244

Caution: The above presented values serve informative purposes only. Set the transmission parameters in accordance with your local network.

Press  button, the message <Restart balance to implement changes> is displayed.

Return to the weighing procedure and restart the balance.

You may use <Available networks> parameter to view the list of networks detected by the balance:

← Available networks

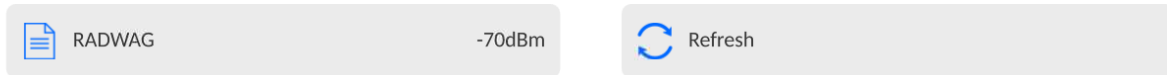

A pictogram with a padlock means that the password is required. Press <Refresh> to search for available networks.

Press <Network status> to check selected network parameters.

← Network status



The selected network and connection parameters are saved to the balance memory. The program connects to the network in accordance with the memory-saved parameters each time the balance is switched on. To change this, select <Forget network> option. The previously selected network gets disconnected.

17.3.1. Hot Spot - General Information

Hot Spot - an open access point allowing wireless connection with the balance by another device - laptop, tablet or phone, using a wireless network based on Wi-Fi standard.

The owner of the Hot Spot decides for himself how, to whom and under what conditions he is going to make his link available by logging in, which requires having an individual user name and password (these data are given while starting the service and are stored in the memory of the balance).

17.3.2. Hot Spot Activation

1. Enter Wi-Fi option

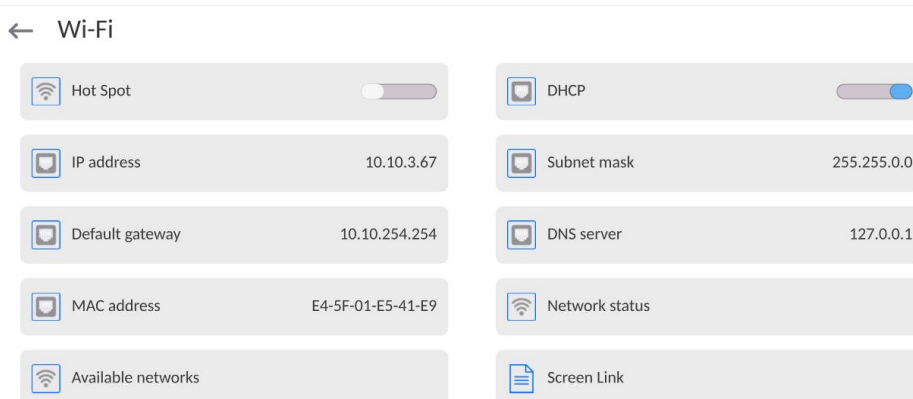

2. Activate Hot Spot, the balance will switch to the service settings after a moment.

Waiting for a service

Please wait

← Wi-Fi

<input checked="" type="checkbox"/> Hot Spot	<input type="checkbox"/> Name
<input type="checkbox"/> Password	<input type="checkbox"/> Link by QR code
<input type="checkbox"/> IP address	<input type="checkbox"/> Subnet mask
<input type="checkbox"/> Default gateway	<input type="checkbox"/> DNS server
<input type="checkbox"/> MAC address	<input type="checkbox"/> Screen Link

3. Enter an individual name and password for access (password must be at least 8 characters long).

← Name

ELIPSIS1234

→

q w e r t y u i o p [X]
a s d f g h j k l [←]
[↵] z x c v b n m , . [↵]
[↩] &123 English [A] [📶]

Waiting for a service

Please wait

← New password













← Repeat the new password



Waiting for a service

Please wait

← Wi-Fi

 Hot Spot <input checked="" type="checkbox"/>	 Name ELIPSIS1234
 Password *****	 Link by QR code
 IP address 192.168.4.1	 Subnet mask 255.255.255.0
 Default gateway 0.0.0.0	 DNS server 127.0.0.1
 MAC address E4-5F-01-E5-41-E9	 Screen Link

4. From now on, the Hot Spot service will be active and the created subnetwork will be visible by other smartphone devices under the name assigned above and you will be able to connect to it using the assigned password.

17.4. TCP Settings

TCP (*Transmission Control Protocol*) is a stream protocol, operating in customer-server mode, enabling communication between two computers. TCP operates in client – server mode. You can establish a connection on the specified server port.

Procedure:

- Enter <Communication> parameters.
- Select <TCP / Port>; a <Port> window with an on-screen keyboard is opened.
- Insert required port number and press  button to confirm.

18. PERIPHERALS

The <Peripherals> menu is located in the <Parameters> menu. To access the Peripherals menu, press the Setup key or the < Setup> quick access button. The peripherals menu provides a list of devices that can cooperate with the balance.

18.1. Computer

Active balance – computer connection is signalled by  pictogram (top bar of the home screen). Carry out configuration using <Computer> submenu.

Procedure:

- Press Setup and select <Peripherals/ Computer>.
- Set balance-computer operation parameters:
 - Computer port

Available options: none, COM 1, COM 2, TCP, USB Free Link

USB FREE LINK - USB type C port (socket no. 10 on the back of the indicator), to which the computer is connected using a USB type A/type C cable.

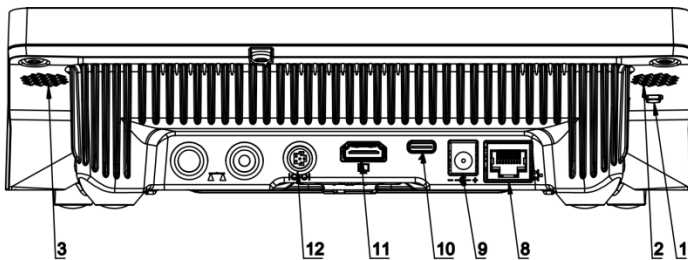

Tool for entering data, it functions as a keyboard. Upon proper modification of the standard or non-standard printout and sending a proper command from the computer, or upon pressing ENTER key located on the operation panel, the data from the non-standard printout are entered directly to computer programs, e.g. Excel, Word, Notepad etc.

To ensure proper operation with Excel-type program, the non-standard printout must be properly configured by inserting the print formatting characters, such as Tab, Enter and language-specific diacritics, into the designed printout. Also remember to set the correct decimal separator (full stop or comma) that the Excel-type program will accept. It can be set in: *Setup/Misc./Decimal point*.

Below is an example of a printout template and the resulting printout in Excel:

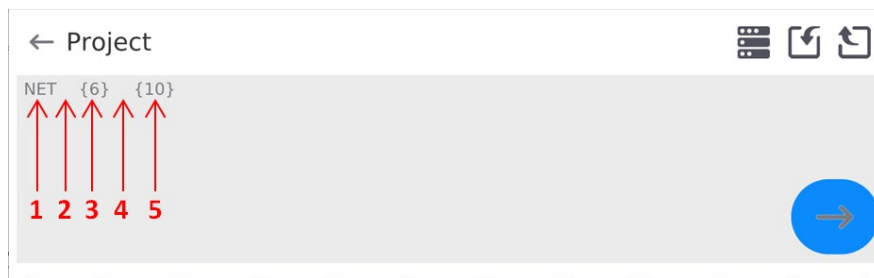

- 1 – fixed text
- 2 – tab key (skip to the next column)
- 3 – variable {6}, net weight in an adjustment unit
- 4 – tab key (skip to the next column)
- 5 – variable {10}, mass unit

	A	B	C	D	E	F	G
1							
2							
3				NETTO:	1,1235 g		
4				NETTO:	1,1455 g		
5				NETTO:	1,1258 g		
6				NETTO:	1,1325 g		

18.1.1. Computer address

Setting a balance address which computer is connected to.



Procedure:

- Enter **<Devices / Computer / Address>** submenu and you will see **<Address>** box with on-screen keyboard.
- Enter address and press  to confirm changes.

18.1.2. Permanent transmission

Activation of balance-computer permanent transmission. After enabling **<Permanent transmission>** parameter, the content of **<Weighing Printout Template>** is continuously sent to the PC.

Procedure:

- Enter **<Devices / Computer / Permanent transmission>** submenu and set relevant value ( - Permanent transmission disabled;  - Permanent transmission enabled).

18.1.3. Interval

Setting frequency of **<Weighing Printout Template>** printout for permanent transmission. Printing frequency can be set in seconds, with an accuracy of 0.1sec. and the range from 0.1 to 1000 seconds.

Procedure:

- Enter **<Devices / Computer / Interval>** submenu and you will see **<Interval>** edition window.
- Enter desired value and confirm by pressing .

18.1.4. Weighing printout template

A unique template for printing from balance to PC.

Procedure:

- Enter **<Devices / Computer / Weighing Printout Template>** submenu. You will see **<Weighing Printout Template>** window with an on-screen keyboard.
- Modify the template and confirm changes by pressing .





18.1.5. Cooperation with E2R System

Activation of cooperation between the balance and **E2R System**. **E2R System** software is a modular system that comprehensively supports production processes related to weighing at various stages.

	<i>Only <Administrator> is allowed to activate <E2R> parameter. In case of cooperating with the <E2R System> software, database edition in the balance is blocked.</i>
---	---

Access path:  / **<Devices / Computer / E2R System>**.

List of options in **<E2R System>** submenu:

Active system	Activation of connection to E2R System :  - connection disabled,  - connection enabled. If the connection is enabled, the  icon in the top bar of the home screen will be visible.
Block product selection	Activation of product selection lock for balance operator:  - lock disabled,  - lock enabled.
Databases	Submenu with configuration of databases that cooperate with E2R System.
Info	List of database events that occur during active connection to E2R System.

18.2. Printer

<Printer> submenu allows you to:

- set port for establishing communication with a printer,
- define printer's code page (default: 1250),
- define control codes for PCL printer or receipt printer.

Caution: Codes must be entered in a hexadecimal form!

- define printout templates.



To ensure correct balance – printer operation (correct printout of diacritical signs of a given language), respective baud rate, obligatory for a given printer, must be chosen (see the printer settings). Additionally, the code page of a sent printout must be accordant with the code page of a printer.

There are two methods for obtaining code page accordance:

- by setting the right code page in printer settings (read the printer manual) – respective to the printout code page set in the balance;

Code page	Language
1250	Polish, Czech, Hungarian.
1252	English, German, Spanish, French, Italian.
1254	Turkish.

- by sending a control code from the balance to the printer, which automatically sets the right code page (respective to the code page set in the balance) before the data printout – it is possible only for printers equipped with this option.

	<i>Default value of printer code page is 1250 – central European code page.</i>
	<i>Detailed description of communication between the balance and the labeller is to be found in 'ANNEX 03'.</i>

USB FREE LINK - USB type C port (socket no. 10 on the back of the indicator), to which the computer is connected using a USB type A/type C cable.

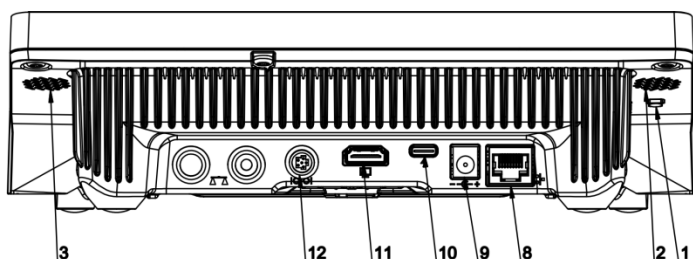

Tool for entering data, it functions as a keyboard. Upon proper modification of the standard or non-standard printout and sending a proper command from the computer, or upon pressing ENTER key located on the operation panel, the data from the non-standard printout are entered directly to computer programs, e.g. Excel, Word, Notepad etc.

To ensure proper operation with Excel-type program, the non-standard printout must be properly configured by inserting the print formatting characters, such as Tab, Enter and language-specific diacritics, into the designed printout. Also remember to set the correct decimal separator (full stop or comma) that the Excel-type program will accept. It can be set in: *Setup/Misc./Decimal point*.

Below is an example of a printout template and the resulting printout in Excel:

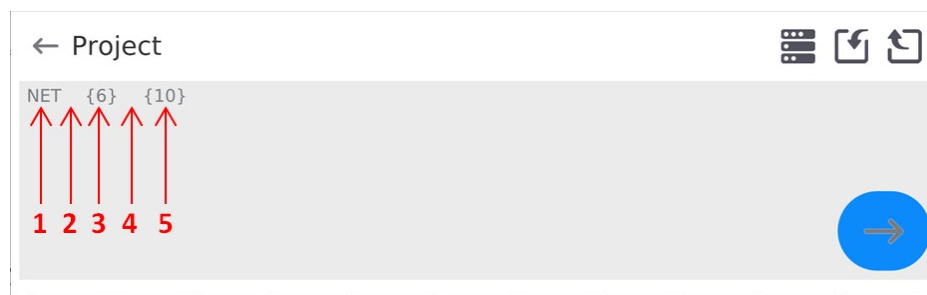





- 1 – fixed text
- 2 – tab key (skip to the next column)
- 3 – variable {6}, net weight in an adjustment unit
- 4 – tab key (skip to the next column)
- 5 – variable {10}, mass unit

	A	B	C	D	E	F	G
1							
2							
3				NETTO:	1,1235 g		
4				NETTO:	1,1455 g		
5				NETTO:	1,1258 g		
6				NETTO:	1,1325 g		

If data with a high information content, such as the SQC report, is to be printed using Free Link, it is imperative that the parameter <Receipt printer speed [character/second]> is set to 15.

← Printer

 Port	COM 1	 Code page	1250
 Control codes		 Receipt printer speed [character/second]	0
 Printouts			

A printout template describes how to print information from databases.

The template can be modified. In order to check the format of a printout template, print the data related to e.g. product parameters. To do it, go to <Products/Edit product> submenu and press printer pictogram.

Default values for particular templates:

Product printout template	{50}
	{51}
Operator printout template	{75}
	{76}
Customer printout template	{85}
	{86}
Warehouse printout template	{130}
	{131}
Package printout template	{80}
	{81}
	{82}

Ambient conditions printout template

```
----- AMBIENT CONDITIONS-----  
      {275}  
      IS T1: {278} °C  
      IS T2: {279} °C  
      THB T: {276} °C  
      THB H: {277} %  
-----
```

Formulation printout template

```
----- Formulation -----  
Formulation name:      {165}  
  Ingredients quantity: {167}  
  Target mass:         {168} g  
  Formulation ingredients: {169}  
-----
```

18.3. Barcode Scanner

The balance enables operation with a barcode scanner. The barcode scanner is used to facilitate quick search for database records:

- Products,
- Operators,
- Customers,
- Packages,
- Warehouses,
- Formulations,
- Pipettes,
- Series in a differential weighing,
- Universal variables.



In <Communication> submenu it is necessary to set baud rate value to a value accordant with bar code scanner (by default 9600b/s). Detailed description of communication between the balance and the bar code scanner is to be found in 'ANNEX 03'.

To configure the barcode scanner, enter:

„**Setup / Peripherals/ Barcode scanner**”.

Caution: Enter **<Communication>** submenu and set baud rate for the barcode scanner (by default 9600b/s). For detailed description of the balance - barcode scanner communication, read **ANNEX E** of this user manual.

18.3.1. Barcode Scanner Port

Procedure:

- Enter **<Peripherals>** parameter and go to „**Barcode scanner / Port**” parameter. Select respective option.

Ports for balance - scanner communication:



- RS 232 (COM1),
- RS 232 (COM2),
- USB

18.3.2.Prefix/Suffix

You can edit <Prefix> and <Suffix> to synchronize the balance program with the barcode scanner.

Caution: In RADWAG-adopted standard, the prefix is 01 sign (byte) hexadecimal format, the suffix is 0D sign (byte) hexadecimal format. For detailed description of the balance - barcode scanner communication, read **ANNEX E** of this user manual.

Procedure:

- Enter <Barcode scanner> submenu,
- Select <Prefix> parameter and enter hexadecimal value using the on-screen keyboard. Press  button to confirm.
- Select <Suffix> parameter and enter hexadecimal value using the on-screen keyboard. Press  button to confirm.

18.3.3.Field Selection

Parameter for specifying for which field the search is to be carried out in particular databases.

Procedure:

- Enter < Peripherals> submenu,
- **Select „Barcode scanner / Field selection”**. List of fields is displayed:

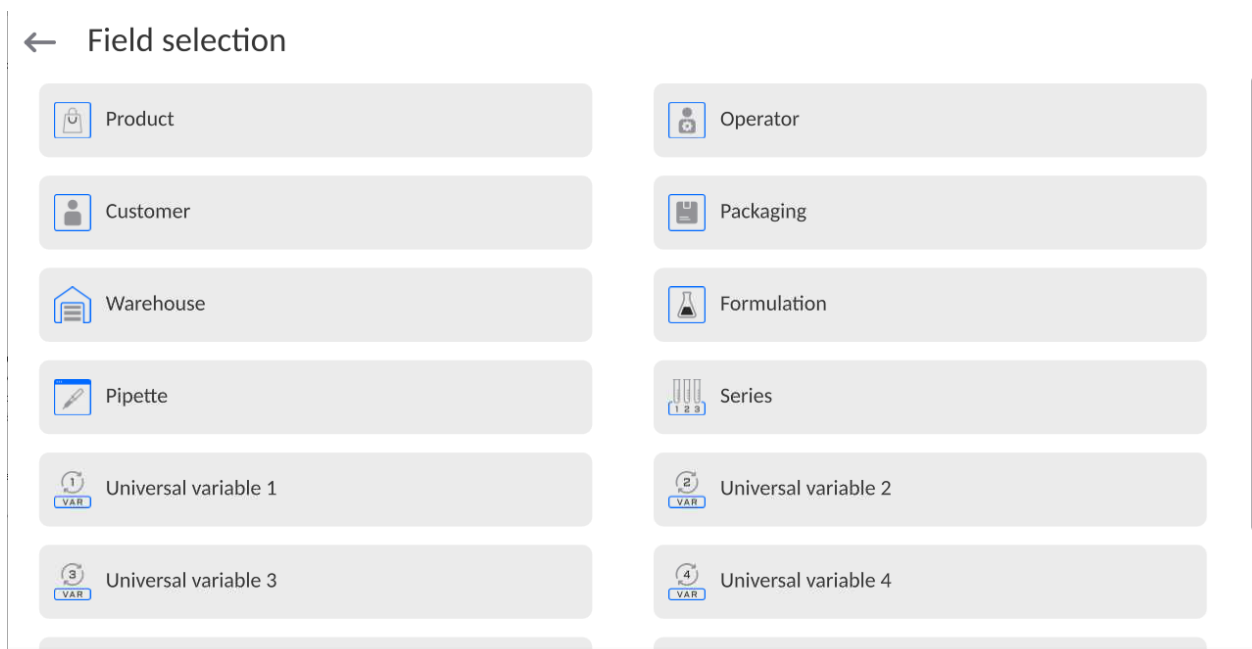

- Select one item from the list. The following parameters may be edited:

Filtering	Parameter allowing you to declare search criteria (see table below)
------------------	---

Offset	Parameter allowing you to set the first significant code's character; characters preceding the first significant character are skipped during comparison search.
Code length	Parameter allowing you to set the number of code's characters to be taken into account during search procedure.
Start marker	Parameter allowing you to declare the starting point of scanned code, taken into account during the search.
End marker	Parameter allowing you to declare the ending point of scanned code, taken into account during the search.
Ignore marker	Parameter allowing you to determine whether start and end markers are to be referred to or skipped during comparison of a scanned code with the code saved to the balance.

Filtering criteria conditioned by field type:

Field selection	Filtering
Product	None, Name, Code, EAN code
Operator	None, Name, Code,
Customer	None, Name, Code,
Packaging	None, Name, Code,
Warehouse	None, Name, Code,
Formulation	None, Name, Code,
Pipette	None, Name, Code,
Series	None, Name, Code,
Universal variables	None, Active

18.3.4.Test

<Test> parameter allowing you to verify if operation of a barcode scanner connected to a balance is correct.

Procedure:

- Enter **<Barcode scanner>** submenu,

- Select **<Test>** parameter; **<Test>** edit box is displayed, it features ASCII and HEX fields.
- The code is scanned and entered to the ASCII and HEX fields; next, the test result is displayed in the bottom part.

When:

- **<Prefix>** and **<Suffix>** declared in the balance settings comply with **<Prefix>** and **<Suffix>** of the scanned code, the test result is **<Positive>**,
- **<Prefix>** and **<Suffix>** declared in the balance settings do not comply with **<Prefix>** and **<Suffix>** of the scanned code, the test result is **<Negative>**,

18.4. Ambient Conditions Module

An ambient conditions module (THB) can be connected to the balance via UDP or USB ports. In order to ensure correct interaction, the correct connection port of the ambient conditions module must be selected.

19. MISCELLANEOUS PARAMETERS

This menu contains parameters facilitating balance operation language, date–time, beep sound, display adjustment, and level control. To enter the **<Misc.>** submenu, press Setup and then press **<Misc.>**.

19.1. Interface Language

Procedure:

Enter the **<Misc.>** submenu.

Select the **<Language>** parameter and set the language.

Available languages: Polish, English, German, French, Spanish, Korean, Turkish, Chinese, Italian, Czech, Romanian, Hungarian, Russian, Serbian.

19.2. Date and Time

You can set the date, time, and their formats.

There are two ways to edit date and time settings:

- Press the **<Date and time>** entry (home screen's top bar).
- Go to **<Setup / Misc./ Date and time>**.

Enter the date and time settings; an on-screen keyboard is displayed. Set the date and time: year, month, day, hour, minute; confirm the changes.

← Date and time

21.03.2023 11:18:35

Additional functions of the <Setup / Misc./ Date and time> submenu:

Name	Value	Overview
Time zone	Europe, Warsaw	Parameter value: name of time zone/country. Particular name contains information regarding summer/winter time change.
Date and time	2016.04.04 08:00:00	Enter this parameter to set an internal clock and date.
Date format	yyyy.MM.dd *	Enter this parameter to select date format. Options: d.M.yy, d/M/yy, d.M.yyyy, dd.MM.yy, dd/MM/yy, dd-MM-yy, dd.MM.yyyy, dd/MM/yyyy, dd-MMM-yy, dd.MMM.yyyy, M/d/yy, M/d/yyyy, MM/dd/yy, MM/dd/yyyy, yy-M-dd, yy/MM/dd, yy-MM-dd, yyyy-M-dd, yyyy.MM.dd, yyyy-MM-dd.
Time format	HH:mm:ss **	Enter this parameter to select time format. Options: H.mm.ss, H:mm:ss, H-mm-ss, HH.mm.ss, HH:mm:ss, HH-mm-ss, H.mm.ss tt, H:mm:ss tt, H-mm-ss tt, HH.mm.ss tt, HH:mm:ss tt, HH-mm-ss tt, h.mm.ss tt, h:mm:ss tt, h-mm-ss tt,

		hh.mm.ss tt, hh:mm:ss tt, hh-mm-ss tt
Hide time	No	Enabling/disabling date and time preview on the home screen.
Time from the Internet	Yes	Enter this parameter to update time and date of a network-connected balance with the network time and date.
Synchronized with the Internet	Yes	Parameter informing whether the time and date values are in sync with the network data.

*) - For date format: y – year, M – month, d – day

***) - For time format: H – hour, m – minute, s – second

The <Date and time> parameter enables preview of declared date and time formats.

← Date and time

The screenshot displays the 'Date and time' settings interface. It consists of eight individual settings cards arranged in two columns. The first column includes 'Time zone' (Europe/Warsaw), 'Date format' (yyyy.MM.dd), 'Hide time' (toggle off), and 'Synchronized with the Internet' (toggle on). The second column includes 'Date and time' (2023.03.23 10:17:45), 'Time format' (HH:mm:ss), and 'Time from the Internet' (toggle on). Each card features a clock icon and a toggle switch where applicable.

Caution: The <Date and time> parameter can be accessed only by an operator with appropriate permissions. The administrator can change the permission level in the <Permissions> menu.

19.3. Extension Module

The extension module allows you to:

- activate compliance with FDA 21 CFR procedures,
- run communication protocol extension, and
- disable standard licence (demo balance mode).

A license number is required for a particular option release in order to run the mode. You must contact the manufacturer if you want to get the number.

Procedure:

Enter the <Misc.> submenu, select <Extension modules> and follow the prompts.

19.4. Sound

Procedure:

Enter the <Misc.> submenu, select <Sound> and set the appropriate option:

Printout confirmation sound	– Yes/No
Touch panel sound	– Yes/No
Sensors	– Yes/No
Volume	– range 0 - 100%

19.5. Visual printout confirmation

The option that allows you to visually confirm the measurement and record it in the weighing record base. After entering  value, every saved measurement will be communicated to the operator through temporary illumination of the mass display in blue.



19.6. Sleep Mode

You can turn on display sleep mode.

Procedure:

Press Setup, then press the < Misc./Display sleep mode> submenu.

Select one of the following options: [None; 1; 2; 3; 5; 10; 15]. Digits stand for minutes. The software returns to the previous menu.

CAUTION:

The display turns to sleep mode only when the balance is not operated (the indication on the screen remains the same). Upon mass change, or pressing any key on the panel, the balance returns to weighing.

19.7. Display Brightness

Display brightness influences the duration of operation of a battery-powered balance. The brighter the screen, the shorter the operation time. To make the balance work longer, reduce the screen brightness.

Procedure:

Press Setup, then press the < Misc./Display brightness> submenu.

Enter the desired value: [0% - 100%]. The display brightness changes automatically, the previous menu is displayed.

19.8. Vibration Detection

The program detects incorrect loading of the weighing pan with the sample. Incorrect loading can lead to increased indication errors. Activation of the 'Vibration detection' function is signalled by the display of a respective pictogram in the weighing result window.

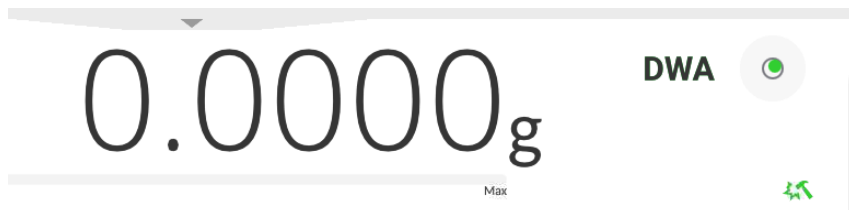

If an incorrectly carried out loading is detected, the pictogram turns red . The measurement result may be affected by a greater error.

Procedure:

- Enter the <Misc.> submenu.
- Select the <Vibrations detection> parameter.
- Select one of the available options:
 - Yes – function on
 - No – function off

19.9. Level Control

The balance is equipped with an Automatic Level Control mechanism.

You can define its operation for non-verified devices.

In the case of verified instruments, the settings are hidden and the balance operates in accordance with factory settings, i.e. <Active with lock>. The weighing process is possible only if the balance is properly levelled.

Procedure:

- Enter the <Misc.> submenu.
- Select the <Level control> parameter, an edit box is displayed.
- Select one of the available options:
 - None– level indicator not displayed, the balance does not control the level status,

- Active – level indicator displayed, the level status is signalled by colour (green→ level status OK, red→ levelling required).
- Active with lock – level indicator displayed, the level status is signalled by colour (green→ level status OK, red → levelling required). For the red level indicator, the 'no Level' alert is displayed and the weighing function is blocked.

Caution: For detailed information on levelling, read section 13.3 of this user manual.

19.10. Decimal Point

Parameter allowing you to set punctuation mark for a printout.

Procedure:

- Enter the <Misc.> submenu.
- Select the <Decimal point> parameter, an edit box is displayed.
- Select one of the available options:
 - Dot
 - Coma

The submenu screen is displayed.

19.11. Proximity Sensors Sensitivity

Parameter allowing you to change the sensitivity of the proximity sensors; the values range between 0 - 9.

By default, it is 5 - 7.

Procedure:

- Enter the <Misc.> submenu.
- Select the <Proximity sensors sensitivity> parameter, an edit box is displayed.
- Select one of the available options. The menu screen is displayed.

19.12. Autotest

The <AUTOTEST> function has been designed to help you assess balance operation and to diagnose the cause of weighing errors (exceeding the maximum permissible values).

AUTOTEST facilitates systematic optimisation of balance settings, which is necessary to maintain the best possible repeatability and weighing time at the workstation. The function

allows you to monitor the parameters at an optional moment and save records from carried out tests.

There are two modules:

AUTOTEST FILTER; AUTOTEST GLP.

Prior to each test, the balance controls the level status, temperature, and humidity.

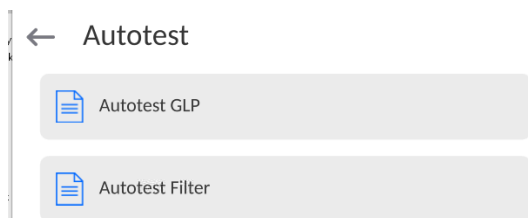

AUTOTEST FILTER

The procedure consists of loading and unloading of the internal weight for all possible 'Filter' and 'Value release' settings; the test requires 10 repetitions. It controls 2 parameters: 'Repeatability' and 'Stabilization time'.

The test takes approximately 1 hour. Upon completion, information regarding the results is obtained.

Optimal settings for particular ambient conditions are provided.

The Autotest Filter enables:

- to achieve the highest measurement repeatability and the shortest measurement time while maintaining an acceptable repeatability value;

test results are stored in the balance memory until it is turned off,

- test results printout,
- direct and fast selection of optimal parameters.

Upon completing the autotest, a summary with the results is displayed.

Information regarding filter settings is provided automatically via respective pictograms:

- settings providing the fastest measurement (the shortest measurement time).
- settings providing the most accurate measurement (the lowest possible value of deviation for 10 measurements).
- settings providing optimal measurement (the lowest value of time and deviation product).

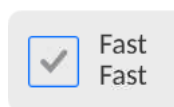

- current settings for filters.

Measurement results:

*Filter type.

*<Value release> parameter value.

*Repeatability of indications expressed as standard deviation.

*Average time of measurement stabilization.

Example:

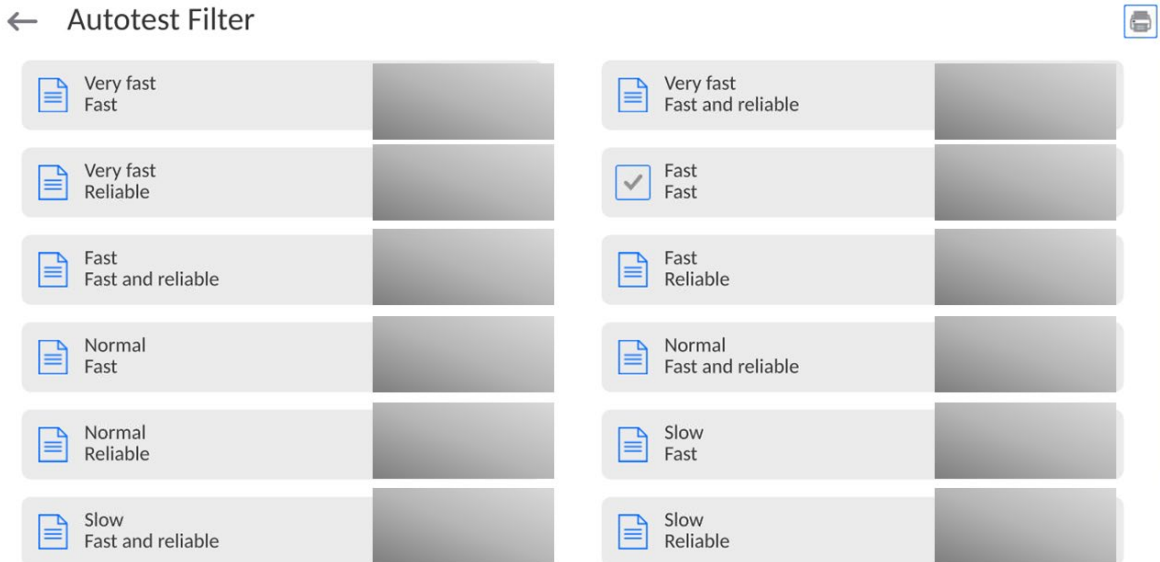

Report example:

```

----- Autotest Filter: Report -----
Balance type                XA 5Y
Balance S/N                 442566
Operator                    Hubert
Software ver.               NL1.6.5 S
Date                        2015.05.07
Time                        09:34:48
-----
Reading unit                 0.0001/0.0001 g
Internal weight mass        148.9390 g
Temperature: Start          25.26 °C
Temperature: Stop           25.66 °C
-----
Filter                       Very fast
Value release                 Fast
Repeatability                 0.0042 g
Stabilization time           4.505 s
.
Filter                       Very slow
Value release                 Reliable
Repeatability                 0.0207 g
Stabilization time           5.015 s

Signature
.....

```

Procedure:

Upon the 'Autotest Filter' function activation, the process starts automatically. A progress bar is displayed. Upon process completion, a summary is displayed and the current filter settings are provided. The report can be printed.



You can abort the process at any moment. To do that, press the <  > button.

AUTOTEST GLP

The Autotest GLP is a test of the repeatability of internal weight loading and the determination of indication error, which error is referred to the balance maximum capacity.

Procedure:

- load the internal weight twice, next load the internal weight ten times,
- adjust the balance,
- calculate and record the value of the standard deviation.
- for a balance with an automatic door, the door opening and closing test is carried out.

Autotest GLP function enables:

Report display and printout,

Record of a report containing basic data, ambient condition values and test results.

Test results:

*Deviation for maximum capacity.

*Value of repeatability expressed as standard deviation.

*Door test result (positive / negative).

Report example:

----- Autotest GLP: Report -----

Balance type XA 5Y
Balance S/N 400010
Operator Admin
Software ver. LLx.x S
Date 2021.01.16
Time 09:17:16

Measurements quantity 10
Reading unit 0.0001 g
Internal weight mass 140.094 g
Filter Average
Value release Fast and precise

Deviation for Max. -0.0118 g
Repeatability 0.00088 g
Signature

Procedure:

Press the test name, a message box is displayed.

Do one of the following:

- Start the subsequent AUTOTEST GLP process,
- Preview completed autotest results and export all saved test results as a *.csv file,
- Delete all saved test results.

You can abort the process at any moment by pressing the <X> button.

The results of completed autotests are displayed in a table (each line containing the date and time of the autotest procedure as well as its result).

To preview particular autotest data, press the respective table line.

In order to print the result of a single autotest, enter its details (see above) and generate a printout by pressing the <Print> key located on the top of the display.

Autotest results can be exported by pressing the <Export> entry in the window with all saved reports. Data is sent to a USB flash drive, connected to the balance USB port, as a *.csv file.

19.13. Start-Up Logo

(option enabled only for authorized operators)

The parameter enables you to change the logo that is displayed at the moment of balance start-up.

19.14. Export of System Events

(option enabled only for authorized operators)

The parameter enables you to generate a special type of file that is automatically saved to a USB flash drive when it is plugged into the USB port. The file helps the RADWAG service diagnose the cause of problems occurring during balance operation.

Procedure:

- Plug a USB flash drive to the balance USB port.
- Enter the <Misc.> submenu.
- Select the <Export system events> parameter.
- The software generates a file and automatically saves it on the USB flash drive.
- The generated file has to be sent to RADWAG.

19.15. Text-To-Speech Conversion



The parameter enables the processing of group names and menu parameters into speech emitted from the indicator speakers.







The emitted voice is only in English.

20. SCHEDULED TASKS

This parameter provides settings for planning a cyclic performance of particular operations, e.g. balance adjustment or display of prompts.

20.1. Adjustment

← Edit record  



 Name	 Code
 Planned operation Automatic adjustment	 Active <input checked="" type="checkbox"/>
 First operation date and time 2023.03.23 12:08:46	 Interval 24 h
 Message	







<Scheduled adjustments> parameter allows you to precisely specify the time for adjustment performance and the interval between successive adjustments. The parameter is not connected with automatic adjustment and its criteria (time, temperature). You can schedule when internal and external adjustments are to be performed. In order to design a schedule for external adjustment, it is necessary to record mass standards for adjustment performance into the balance memory.

Procedure:

Enter data of mass standards intended for external adjustment performance; to do it:

Enter operator menu, select <Adjustment> submenu and find <Adjustment weights> parameter.

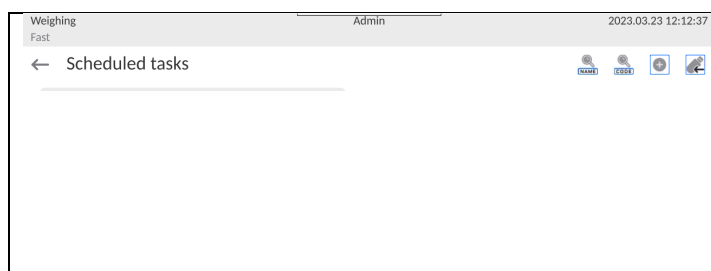

← Edit record  

 Name ETALON 100 g	 Code 1234
 Class E2	 Serial number 654321
 Mass 100 g	 Set number KP 01

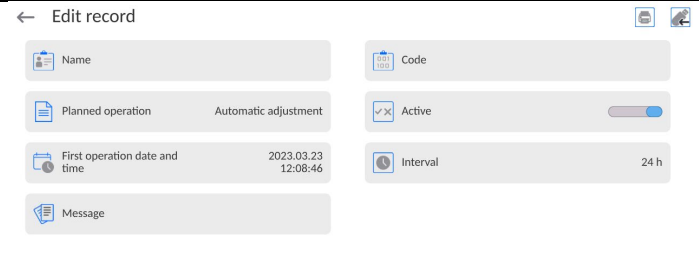

Enter operator menu, select <Scheduled tasks> parameter.

A window opens in which an authorised user (Administrator) can add entries with scheduled adjustments.

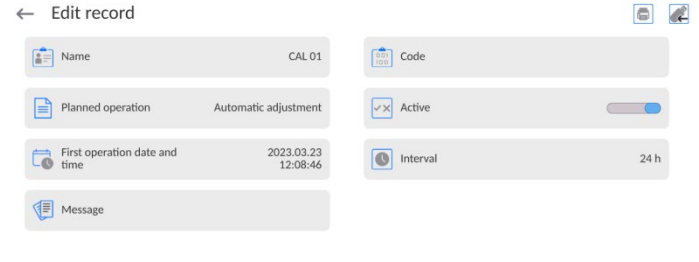
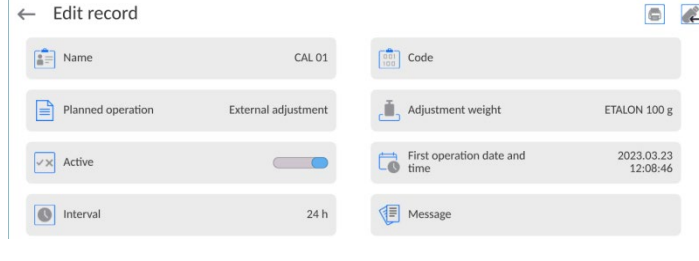
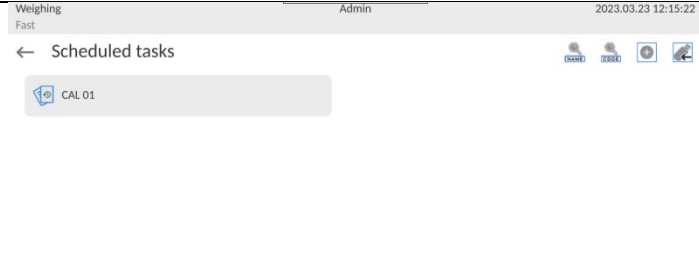
 <p>← Edit record</p> <p>Name: [empty] Code: [empty]</p> <p>Planned operation: Automatic adjustment Active: <input checked="" type="checkbox"/></p> <p>First operation date and time: 2023.03.23 12:08:46 Interval: 24 h</p> <p>Message: [empty]</p>	<p>In order to add a new entry, press  button, wait for a window with data on the scheduled adjustment to open.</p>
	<p>Select task: automatic adjustment (internal or external).</p>
 <p>← Edit record</p> <p>Name: CAL 01 Code: [empty]</p> <p>Planned operation: Automatic adjustment Active: <input checked="" type="checkbox"/></p> <p>First operation date and time: 2023.03.23 12:08:46 Interval: 24 h</p> <p>Message: [empty]</p>	<p>For automatic adjustment option, enter data on the adjustment and its schedule.</p>
 <p>← Edit record</p> <p>Name: CAL 01 Code: [empty]</p> <p>Planned operation: External adjustment Adjustment weight: ETALON 100 g</p> <p>Active: <input checked="" type="checkbox"/> First operation date and time: 2023.03.23 12:08:46</p> <p>Interval: 24 h Message: [empty]</p>	<p>For external adjustment option, enter data on the adjustment, mass standard used for the adjustment performance and its schedule.</p>
 <p>Weighing Fast Admin 2023.03.23 12:15:22</p> <p>← Scheduled tasks</p> <p>CAL 01</p>	<p>When all necessary data has been introduced, return to the previous window. The window features newly added entry.</p>





Upon entering all data, exit the menu.

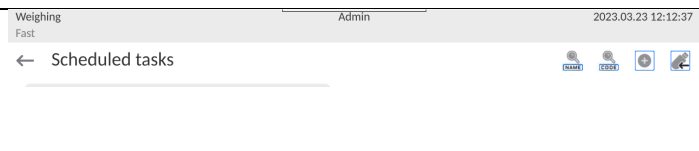

Now all the adjustments are carried out automatically as scheduled and with specified time intervals.

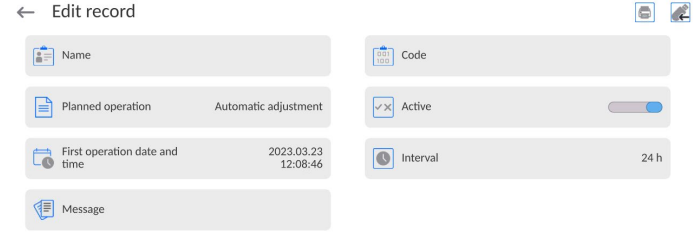
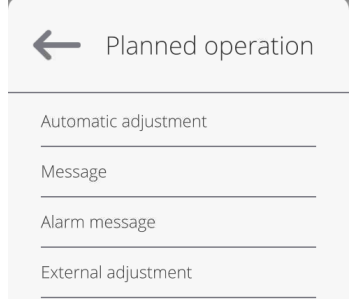
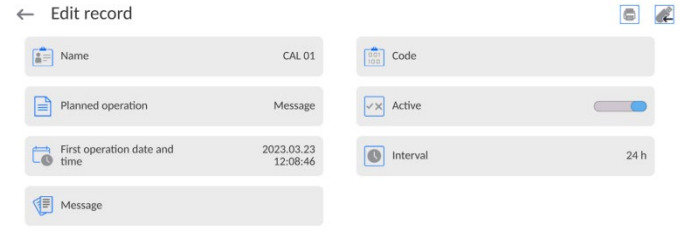
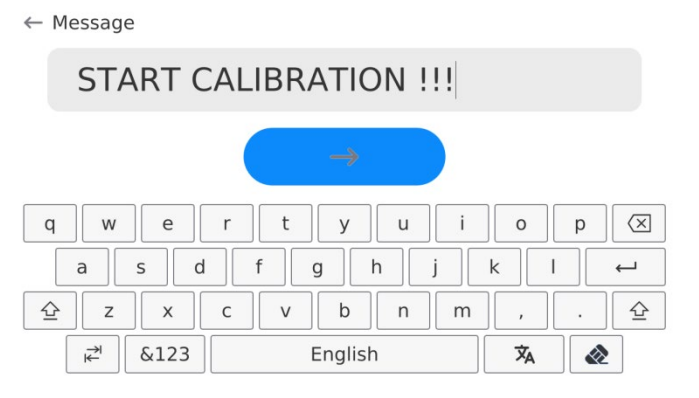
20.2. Message

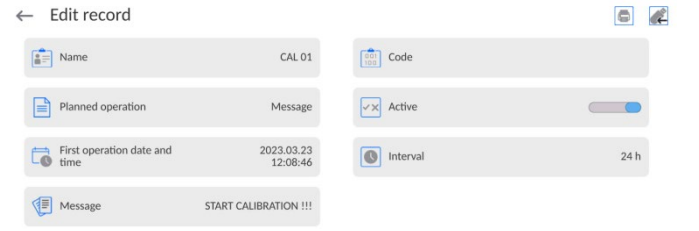
This parameter enables to declare precise time and time interval for display of a special prompt informing the user on the necessity to take up a particular action.

 <p>Weighing Fast Admin 2023.03.23 12:12:37</p> <p>← Scheduled tasks</p>	<p>Enter user menu, next enter <Scheduled tasks> submenu.</p> <p>In order to add an operation, press <</p>
---	---

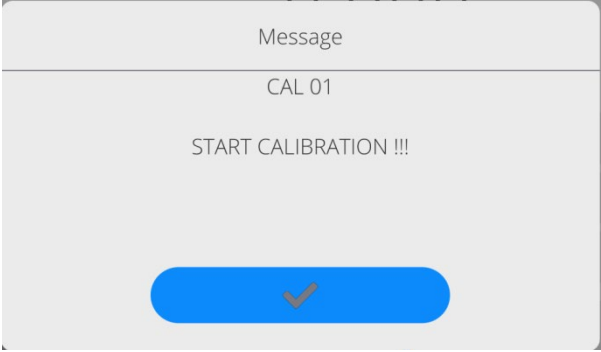
	 button placed in a toolbar.
	<p><Edit record> box is displayed, press <Scheduled tasks> field. <Scheduled tasks> box is displayed.</p>
	<p>Select <Message> option.</p>
	<p>Message settings box is displayed. Set message display frequency (first display, time interval), select <Message> parameter and enter message text.</p>
	<p>Press  button to confirm.</p>
	<p>A previous window is displayed.</p>
	<p>In <Scheduled tasks> box, a newly added operation is displayed. Go to the home screen.</p>

	<p>When message display criterion is met (time), message box is displayed automatically.</p> <p>Press <  > button, the message box gets closed, perform the operation.</p>
---	--



21. UPDATE

The update function allows for the updating of:

- User-related area: APPLICATION.
- main board (administrator exclusively).

An update takes place automatically by loading data from a USB flash drive connected to the balance USB port.

Procedure:

- Prepare a USB flash drive with the update file. Required file extension: **.lab4*.
- Connect the USB flash drive to the USB port of the indicator.
- Log in as the Administrator.
- Press  button to enter the balance menu.
- Select <Update>  option.
- Select <Application> field.
- The display previews the content of the USB flash drive; search for the update file and press its name.
- The balance is automatically restarted, and the balance application is automatically updated.
- If the balance does not restart, force it to restart by turning it off and on again.

The update of the main board file is analogous; required file extensions: **.cm4mbu*.

22. ABOUT (system info)

The 'About' menu provides information on the balance and balance program. Most parameters in this menu are for informational purposes only.

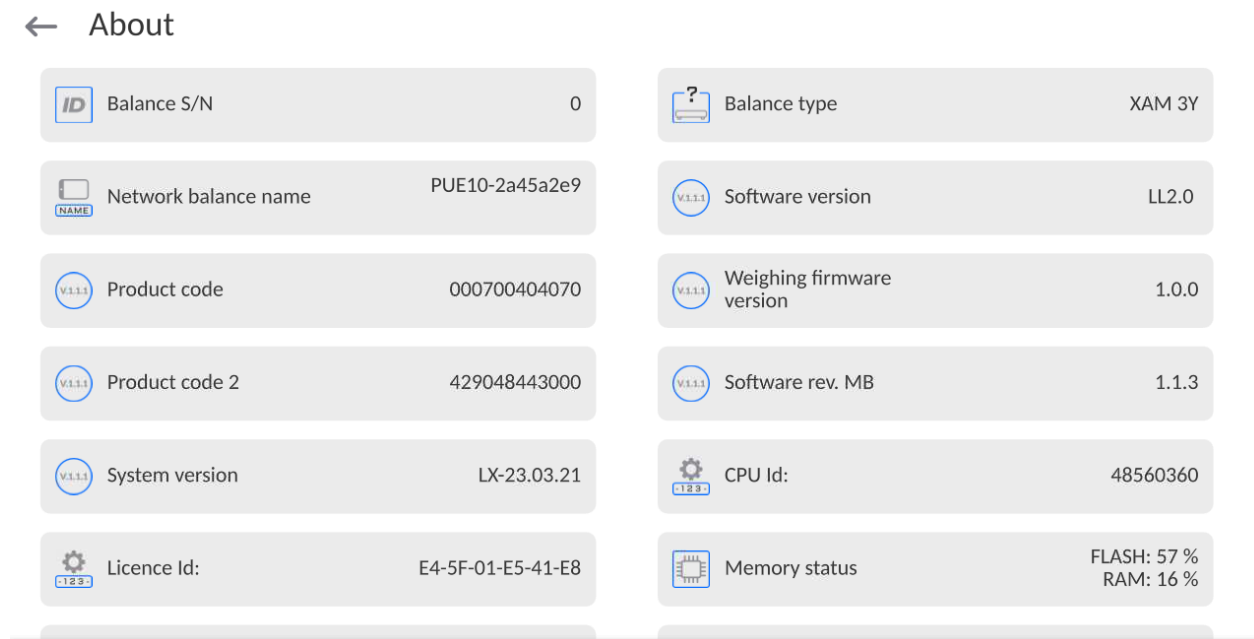

The <Ambient conditions> parameter displays a preview of the current ambient conditions: temperature, humidity, pressure (if the balance features ambient conditions sensors).

The <Print settings> parameter enables you to send all parameters to a printer port.

23. COMMUNICATION PROTOCOL

	Szczegółowy opis protokołu komunikacji wagi z komputerem znajduje się w instrukcji „CBCP-07”.
---	--

23.1. Manual Printout / Automatic Printout

It is possible to generate printouts either manually or automatically.

- Manual printout: wait for a stable indication and press  button.
- An automatic printout is generated automatically in accordance with the parameters set for the automatic printout (read section 12.5).

The content of a printout depends on the settings of the <Standard printout> parameter and the <Weighing printout template> (read section 12.5).

Mass printout format:

1	2	3	4 -12	13	14	15	16	17	18
stability marker	space	character	mass	space	unit			CR	LF

Stability marker [space] if stable
 [?] if unstable
 [!] if air buoyancy compensation function is on
 [^] if high limit is out of range
 [v] if low limit is out of range

Character [space] for positive values
 [-] for negative values

Mass 9 characters with decimal point, right justification

Unit 3 characters, left justification

Example:

_____ 1 8 3 2 . 0 _ g _ _ CR LF - a printout generated,
 with reference to the <Weighing printout template> settings, from the balance upon

pressing the  key:

N (measurements quantity)	NO	Universal variable 1 ... 5	NO
Date	NO	Net	NO
Time	NO	Tare	NO
Level status	NO	Gross	NO
Customer	NO	Current result	NO
Warehouse	NO	Supplementary unit	NO
Product	NO	Mass	YES
Packaging	NO	Non-standard printout	NO

24. PERIPHERAL DEVICES

The 5Y series balance can operate with the following peripheral devices:

- computer,
- EPSON receipt printer,
- PCL6-capable printer (*Printer Command Language*),
- barcode scanner,
- fingerprint reader,
- peripheral device operating using the ASCII communication protocol.

Caution: Only accessories listed on the RADWAG website can be connected to the balance.

25. ERROR MESSAGES

Max weighing threshold exceeded
Unload the weighing pan

Min weighing threshold exceeded
Install weighing pan

Zeroing out of range
Press tarring button or restart the balance

Display capacity out of range
Unload the weighing pan

Tarring out of range
Press zeroing button or restart the balance

Start mass out of range
Install weighing pan

Zeroing/tarring time out of range
Weighing indication unstable

-no level- Balance not levelled









-Err 100- Weighing module restart





























In process An ongoing process in the course of which the indication may be unstable (automatic feeder – the process of feeding a pill, or mass comparator – the process of load change)

26. ADDITIONAL EQUIPMENT

Type	Name
RTP-UEW80 or RTP-RU80	Dot printer
	PCL6-capable printers (<i>Printer Command Language</i>) - connected via the USB port
LS2208	Barcode scanner
SAL	Anti-vibration table for the XA series balances
	PC keyboard

27. ANNEX B - Programmable Buttons List

Pictogram	Name
	None
	Profile
	Adjustment
	Working mode
	Products
	Packaging
	Customers
	Operator

	Warehouses
	Zero
	Tare
	Tare setting
	Disable tare
	Enable tare
	Print
	Header printout
	Footer printout / C label
	Print CC label
	Lot number
	Butch number
	Edit universal variable 1
	Edit universal variable 2
	Edit universal variable 3
	Edit universal variable 4
	Edit universal variable 5
	Statistics
	Add to statistics
	Zero statistics
	Zero CC statistics
	Zero all statistics
	Print and zero statistics
	Print and zero CC statistics
	Label count
	C label count
	CC label count
	Logout

	Parameters
	Working mode
	Units
	Help
	Create screenshot
	Voice commend
	Pipettes
	Move to position
	Select pipette calibration order
	Repeat the most recent order
	Disable last digit display
	Disable display of last two digits
	Disable display of last three digits
	Accept
	Abort



RADWAG WAGI ELEKTRONICZNE
ZAAWANSOWANE TECHNOLOGIE WAGOWE

