



A RICE LAKE WEIGHING SYSTEMS COMPANY

# DFWIECEX

USER MANUAL

ENGLISH

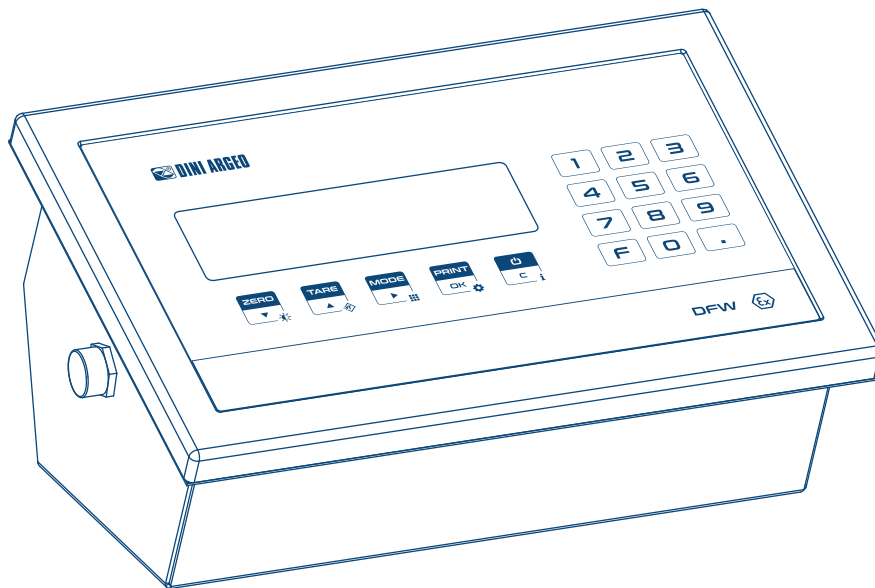

[www.diniargeo.com](http://www.diniargeo.com)



TM



<b>INTRODUCTION</b>	<b>5</b>
<b>WARNINGS</b>	<b>5</b>
<b>GENERAL FEATURES</b>	<b>6</b>
MAINS POWER SUPPLY	7
BATTERY POWER	7
AUTOMATIC ZEROING WHEN THE SCALE IS SWITCHED ON	7
BATTERY ENERGY SAVING	8
AUTOMATIC SWITCH-OFF	8
AVAILABLE TARE FUNCTION	8
DISPLAY	9
IDENTIFICATION OF THE INSTRUMENT'S METROLOGY SOFTWARE	10
<b>BASIC FUNCTIONS</b>	<b>11</b>
ON	12
OFF	12
ZERO	12
AUTOMATIC TARE	13
CLEARING THE TARE	13
SETTING A KNOWN TARE VALUE (PT)	14
PRINTING (AND REPRINTING THE LAST TICKET )	15
METRIC INFORMATION	15
<b>ADDITIONAL FUNCTIONS</b>	<b>16</b>
SETTING QUICK KNOWN TARE VALUE (PT)	17
20 TARES ARCHIVE	17
AUTOMATIC TARE CLEARING	18
NUMERIC IDS	19
DATE AND TIME	20
<b>ADVANCED FUNCTIONS</b>	<b>21</b>
HOW TO ENTER THE FUNCTIONS MENU	22
WEIGHING WITH HIGH RESOLUTION VIEW - <i>h r r E5</i>	23
HORIZONTAL WEIGHT TOTALISATION - <i>toEPL</i>	25

MIXING OF MULTIPLE COMPONENTS - <i>FoRMuL</i>	27
COUNTER - <i>Count</i>	29
WEIGHT CHECK - <i>ChECk</i>	32
UNIT OF MEASURE CONVERSION - <i>ConVEr</i>	35
PERCENTAGE WEIGHING - <i>PERC</i>	36
FREEZING OF WEIGHING ON DISPLAY - <i>hold</i>	39
EXCHANGE BETWEEN NET WEIGHT AND GROSS WEIGHT- <i>net .Gro</i>	40
<b>CONFIGURATION MENU</b>	<b>41</b>
<i>CLoCk</i> - DATE AND TIME	42
<i>PREc . ID</i> - HIGH RESOLUTION READING DIVISION	42
<i>ALibi</i> - READING THE ALIBI MEMORY	43
<i>SEtPnt</i> - RELAY OUTPUTS	43
<i>FiLter</i> - WEIGHING FILTERS	44
<i>SCrEEn</i> - ADJUSTING THE DISPLAY	45
<i>tArE</i> - TARE	46
<i>AutoFF</i> - AUTOMATIC SWITCH-OFF	46
<i>tICK . rES</i> - TICKET NUMBER RESET	46
<i>rESEt</i> - FACTORY CONFIGURATION RESET	47
<i>diAG</i> - DIAGNOSTICS	47
<b>FAQ</b>	<b>48</b>
PRINTING	49
WEIGHT TOTALISATION	49
TARE	49
WEIGHING	50
COUNTER	50
<b>ERROR MESSAGES</b>	<b>51</b>

## INTRODUCTION

---

The purpose of this manual is to inform the user of the different operating modes of the weight indicator, the functions of the keys and the display indications.

**It is advisable to carefully follow the instructions for programming the weight indicator; performing actions not indicated in this manual may impair the proper operation of the scale.**

In addition to all the typical features of a high-precision scale, the indicator offers additional user options such as unit of measure conversion to pounds, net weight/gross weight conversion, setpoint on gross or net weight, input/output weighing, universal single scale repeater, multi-scale repeater, approved PC weight transmission with alibi memory, +/- tolerance check, sample weight percentage, weight freeze display, peak detector, weighing totaliser and counter.

These features make it suitable for both industrial use and for legal use in relations with third parties and in trade, satisfying the most current data transmission and printing requirements by means of its two bidirectional serial outputs.

**The indicator is compliant for use in hazardous areas according to IECEx / Atex regulations.**

The utmost care has been taken in compiling this manual, but reports of any inaccuracies are always welcome.

## WARNINGS

---

The instrument is covered by warranty and **MUST NOT BE OPENED WITH BY THE USER** under any circumstances.

Any attempt at repair or modify the unit may expose the user to the danger of electric shock and voids any warranty conditions.

Any problem with the unit or the system must be reported to the manufacturer or to the retailer where it was purchased. In any case, **TURN OFF THE POWER SUPPLY** before any operation.

The instrument is isolated between the hazardous voltage zone and parts accessible to the user.

- Do not spill liquids on the indicator (except for models with IP65 or higher protection).
- Do not use solvents to clean the indicator.
- Do not expose the instrument to direct sunlight or heat sources
- Place or secure the indicator and platform on a vibration-free base.
- All indicator connections must be made in accordance with applicable regulations in the area and environment of installation.

Anything not expressly described in this manual constitutes improper use of the equipment.

**Do not install in an environment where there is a risk of explosion.**



The crossed-out wheeled bin symbol on the product indicates that the product, at the end of its working life, must be taken to the appropriate separate collection centres or returned to the retailer when a new equivalent product is purchased. Appropriate separate collection of the product for subsequent recycling helps to avoid potential negative effects on the environment and health and promotes the recycling of materials. Unauthorised disposal of the product by the user will result in the application of administrative sanctions provided for by law.

# GENERAL FEATURES

## of the scale

Mains power supply.....	7
Battery power.....	7
Automatic zeroing when scale is switched on.....	7
Keypad lock.....	7
Battery energy saving.....	8
Automatic switch-off.....	8
Available tare function.....	8
Display.....	8
Identification of the instrument's metrology software.....	10

### MAINS POWER SUPPLY

---

The indicator is provided with an external power supply. Refer to the dedicated manual for installation and warnings. Current safety regulations must be observed, including the use of a "clean" line free from interference and disturbance caused by other electronic equipment.

### BATTERY POWER

---

#### Internal battery level indication

 Charged battery

 Low battery

The message `LoB.bAtt` anticipates the automatic switch-off of the instrument.

#### Battery charging indication



### AUTOMATIC ZEROING WHEN THE SCALE IS SWITCHED ON

---

If a weight of less than 10% of the capacity is present on the scale when it is switched on, it is automatically reset to zero. This function is useful for automatically zeroing a container, pallet or small structure, without having to recalibrate the scale.

**i**

*Weights greater than 10% can be reset by adjusting the source calibration.  
Automatic zeroing can be deactivated when the scale is switched on.*

 *Automatic zeroing when the scale is switched on is an advanced configuration.*

### KEYPAD LOCK

---

The indicator keypad can be deactivated to avoid accidentally executing available functions.

 *The keypad lock provides an advanced configuration.*

## BATTERY ENERGY SAVING

---

The instrument is equipped with advanced battery saving functions designed to increase the operating time.

 *Battery power saving provides an advanced configuration.*

## AUTOMATIC SWITCH-OFF

---

This function is activated when the scale is completely empty and unused for the preset time (*5 minutes as standard*). To activate or deactivate the automatic switch-off, enter the configuration menu in the section *AutoFF* section (see page 46).

### WARNING

In weight totalisation and formulation mode, the automatic switch-off causes the loss of the totals in progress. In counting and percentage weighing mode, automatic switch-off causes the loss of the reference data entered.

## AVAILABLE TARE FUNCTION

---

The tool allows you to choose the specific tare functionality for your needs:

- "locked" tare (*factory configuration*).
- "Unlocked" tare: automatically clears each time the scale is unloaded. Useful to avoid errors when the tare changes with each weighing.
- Tare acquired automatically by the scale. Acquisition only takes place if there is no other tare value in memory.
- Tare functions disabled.

To customise the tare function, enter the configuration menu in the section *TARE* (see page 46)



**DISPLAY**

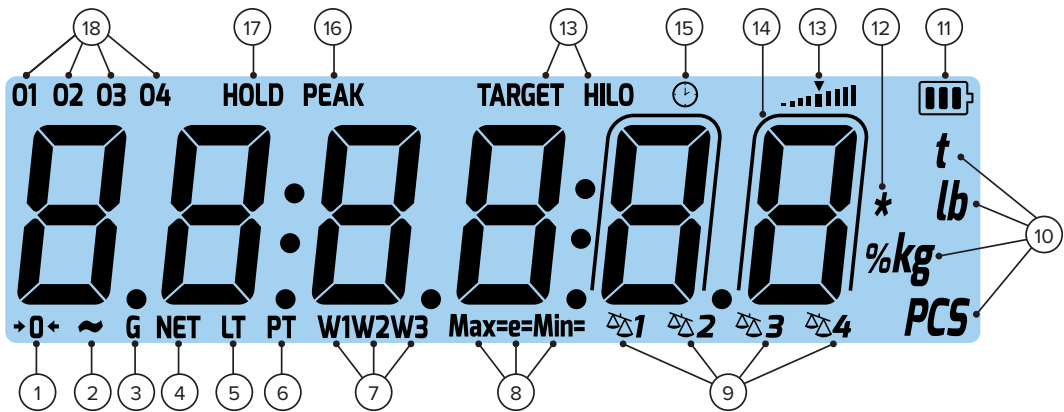

Number	Symbol	Description
1	→0←	The scale is empty and at zero gross.
2	~	The weight is unstable.
3	G	The displayed weight is gross.
4	NET	The displayed weight is net. A tare has been stored.
5	LT	A locked tare is active.
6	PT	A manual tare is active.
7	W1 W2 W3	They indicate the active weighing range.
8	Max= Min= e=	Metric information is being displayed.
9	△1 △2 △3 △4	This indicates which scale the displayed weight refers to
10	t lb kg g % PCS	Units of measurement - tonnes t, pounds lb, kilograms kg, grams g, percentage %, number of pieces PCS.
11	🔋	Battery voltage level.
12	*	This indicates that a key has been pressed. In some operating modes, this indicates that a specific function is active.
13	LO TARGET HI ...	Indication of weight check function thresholds (LHERR).
14	📏	The weight is being displayed in high resolution.
15	🕒	The time is being shown on the display.
16	PEAK	The peak function (PEAK) is active.
17	HOLD	The weight lock function (hold) is active.
18	01 02 03 04	This indicate active relay outputs only with optional board.

## IDENTIFICATION OF THE INSTRUMENT'S METROLOGY SOFTWARE

### 1. Turn off the scale

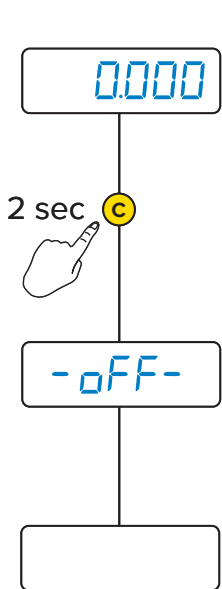

### 2. Follow the procedure:

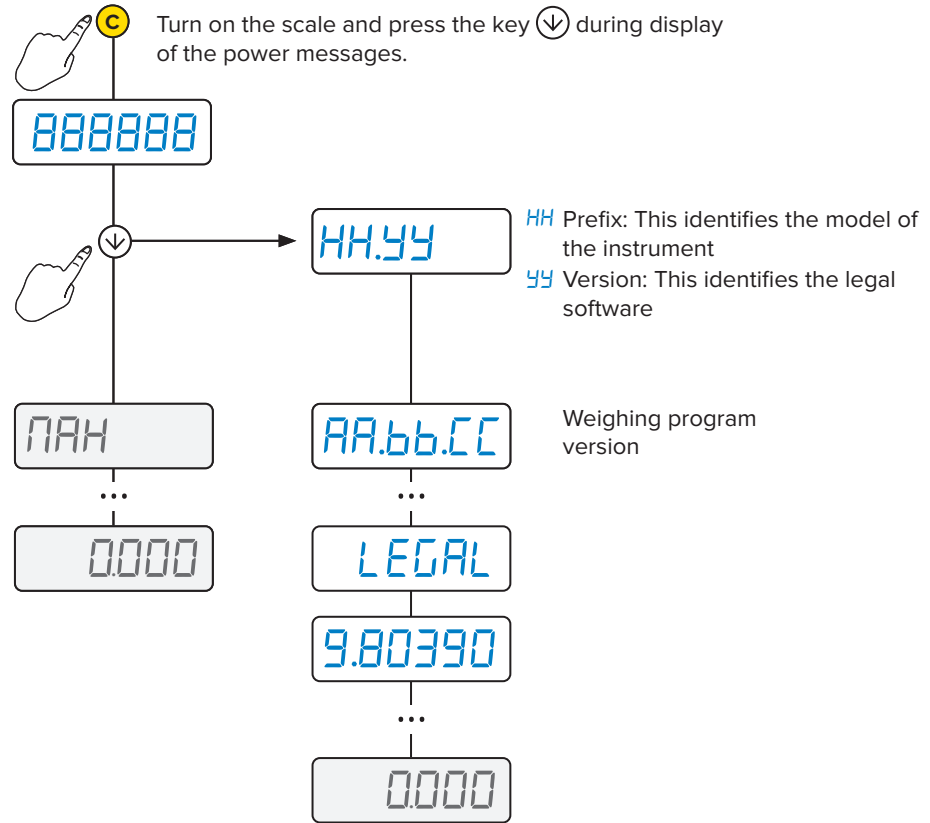

# BASIC FUNCTIONS

## of the scale

On.....	12
Off.....	12
Zero.....	12
Automatic tare.....	13
Clearing the tare.....	13
Setting a known tare value (PT).....	14
Printing.....	15
Metric information .....	15
Adjusting the display brightness.....	16

## ON

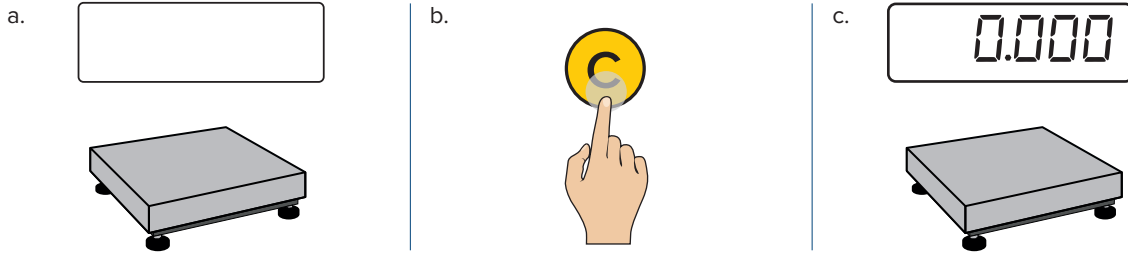

## OFF

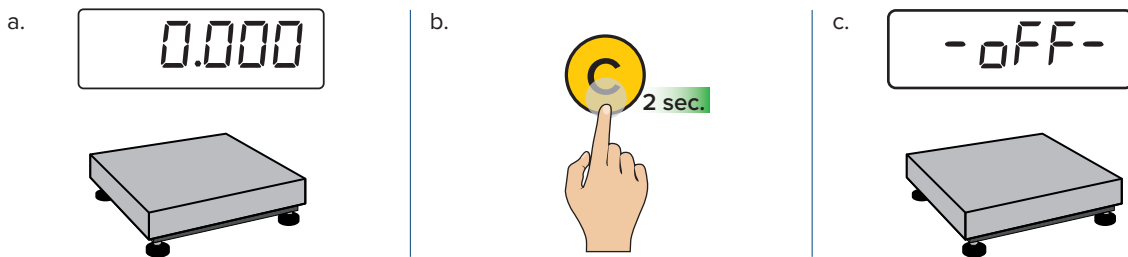

## ZERO

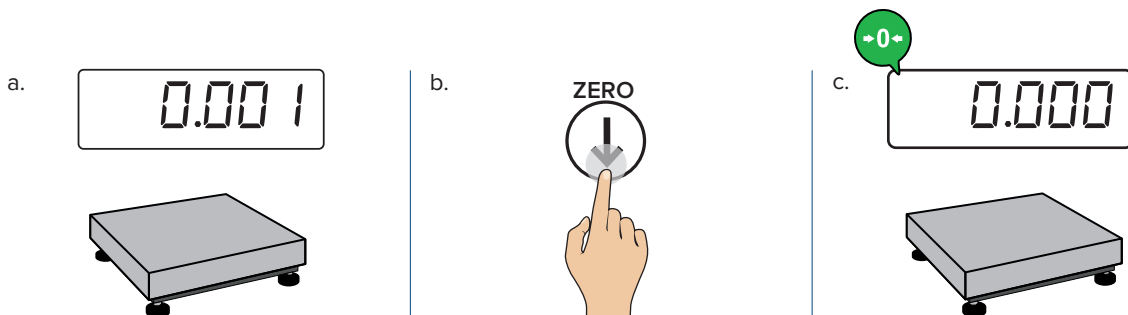

## AUTOMATIC TARE

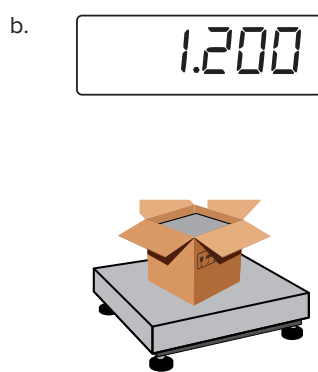
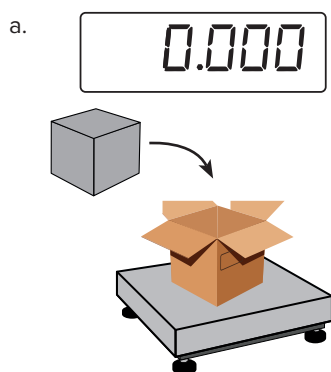
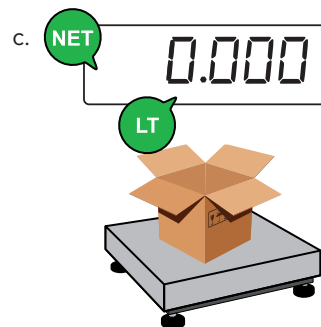
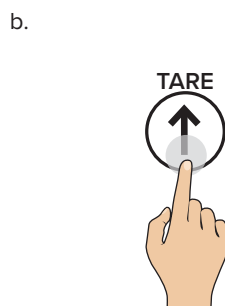
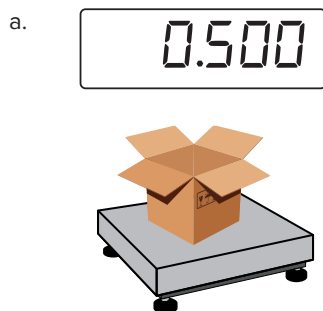

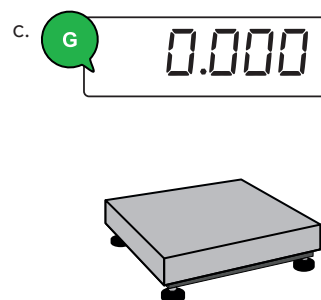
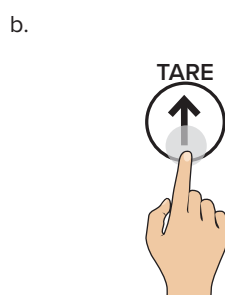
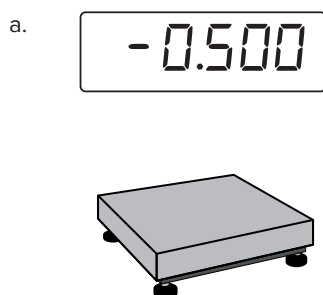

## CLEARING THE TARE





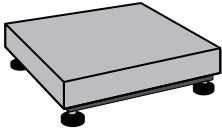



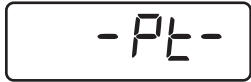

## SETTING A KNOWN TARE VALUE (PT)





a.  



b.  

c. 

d.    
 Setting the tare value  
*How to set the value*  
     
 or  
 ... 

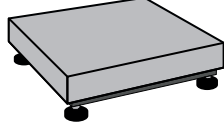
e.  

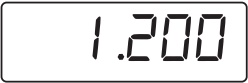
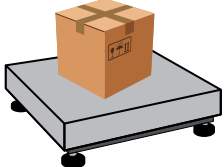
f.  

g.     
 0,500 kg   
 1,200 kg



The tare can be entered rapidly:

a. Setting the tare value

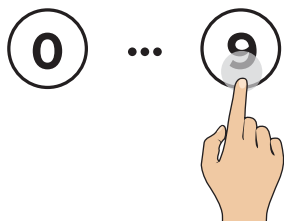

b.



## PRINTING (AND REPRINTING THE LAST TICKET )

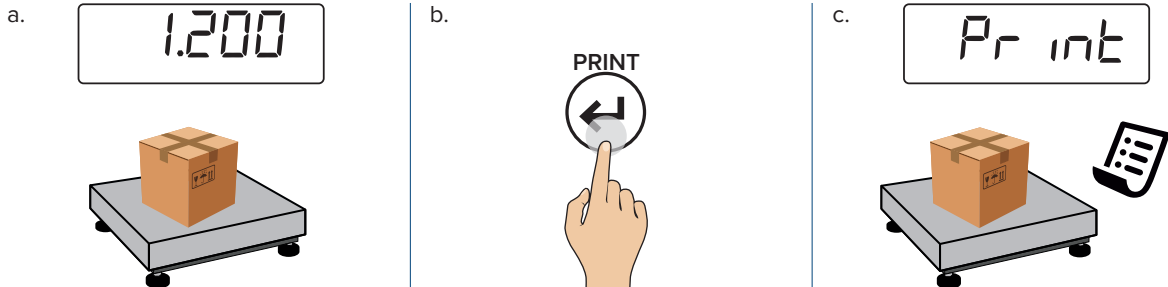

For reprinting the last ticket (for models with extended keypad)

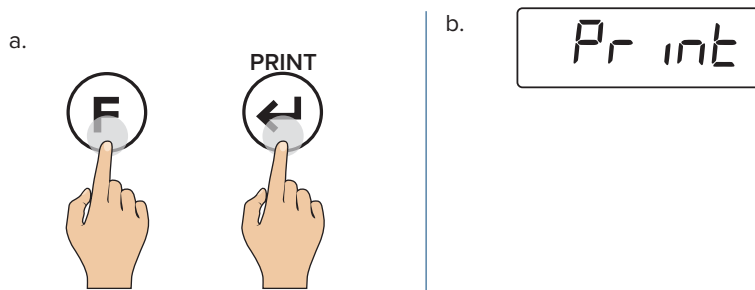

## METRIC INFORMATION

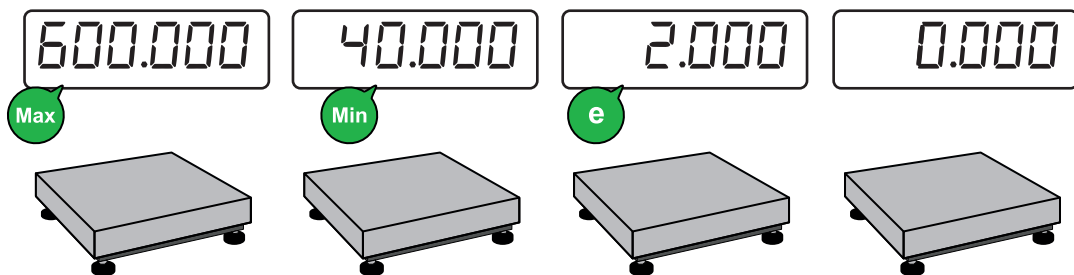
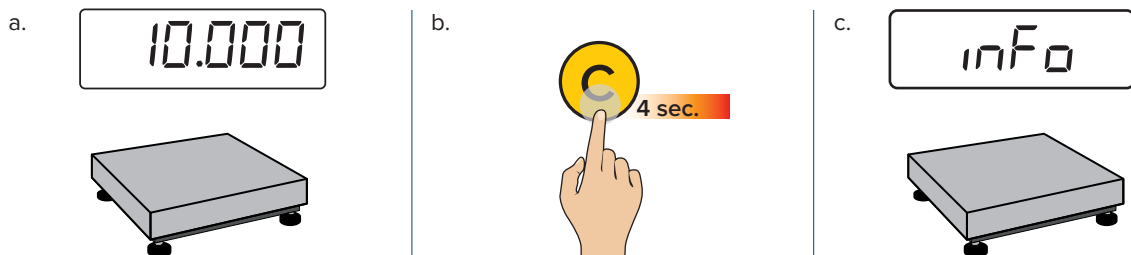

# ADDITIONAL FUNCTIONS

Setting a tare value (PT) .....	17
20 tares archive .....	17
Automatic tare clearing .....	18
Numeric IDs .....	19
Date and time .....	20



## SETTING QUICK KNOWN TARE VALUE (PT)

a. Setting the tare value

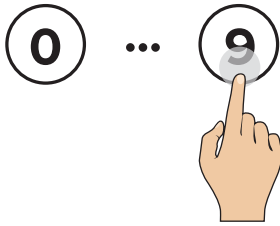

b.



## 20 TARES ARCHIVE

This can be used to save the most frequently used tares (up to 20) for easy activation by quick recall.

Example

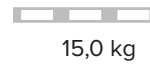

### How to store a tare

a.

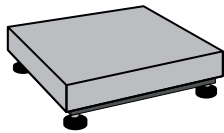

b.



c.



Select the memory

*How to set the value*



d.



e.



Enter the tare value

*How to set the value*



f.



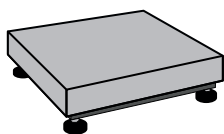

g.



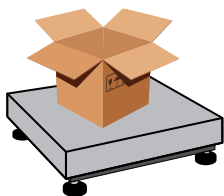

How to recall a stored tare

a. 

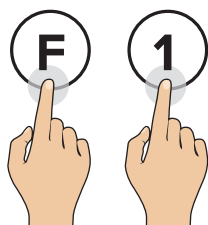

b. 



c. 

Select the memory

How to set the value

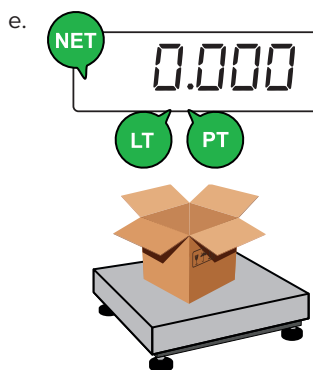
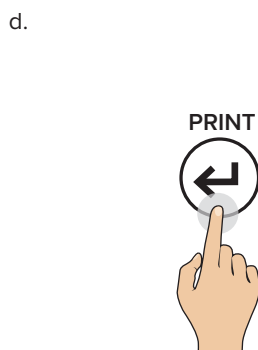

**AUTOMATIC TARE CLEARING**

a. 

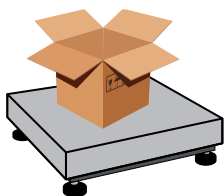

b. 

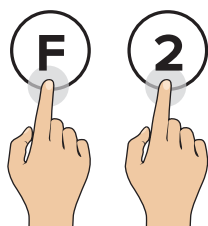

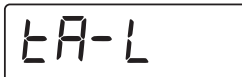
c. 

Automatic clearing off



Automatic clearing on:  
the tare will be auto-  
matically deleted when  
the scale is completely  
unloaded.

## NUMERIC IDS

The instrument has two memories for temporary recording numeric codes that can be used to identify the product, operator, batch, etc. If entered, these codes will appear on the ticket at the time of printing.

### How to enter the ID

a.

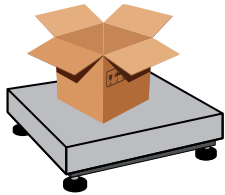

b.

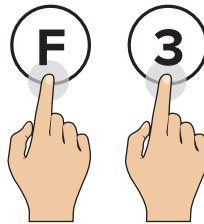

c.

Select the memory.

How to set the value



d.



e.

Enter the desired ID  
(up to 10 numeric digits)

How to set the value

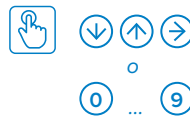

f.

### How to activate automatic ID clearing

a.

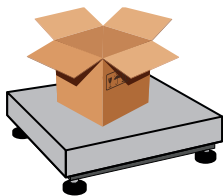

b.

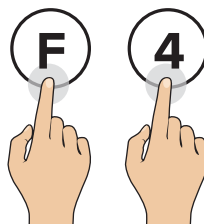

c.

Select the memory

How to set the value



d.



e.

Automatic clearing off.

Automatic clearing on: the entered ID will be automatically deleted when the scale is completely unloaded.



Numeric IDs are automatically reset when the scale is switched off.





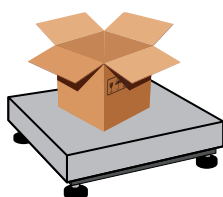

## DATE AND TIME

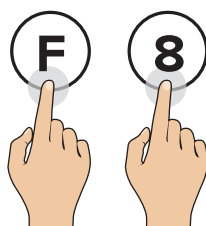
a. 



b. 



c.    
  
  
  

**i**

Only if the date and time option is present.

# ADVANCED FUNCTIONS

## of the scale

How to enter the functions menu and select the desired function .....	22
High resolution weighing (h i . r E5).....	23
Weight totalisation (t o t A L) .....	25
Mixing of multiple components (F o r m U L).....	27
Counter (C o u n t).....	29
Weight check (C h E C K) .....	32
Unit of measure conversion (C o n V E r).....	35
Percentage weighing (C P E r C).....	36
Freezing of weighing on display (C h o L d).....	39
Gross/net weight display (n E t . G r o).....	40

## HOW TO ENTER THE FUNCTIONS MENU

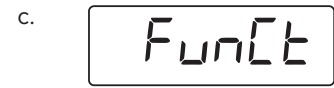
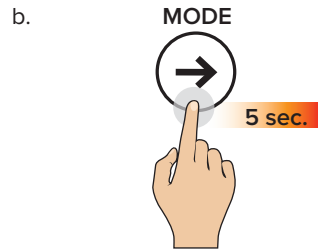
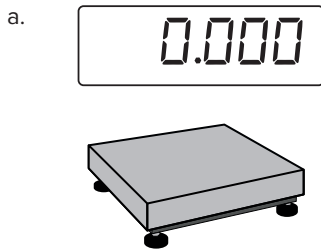

The indicator is in the function menu: the currently active function appears.

d. Select the function

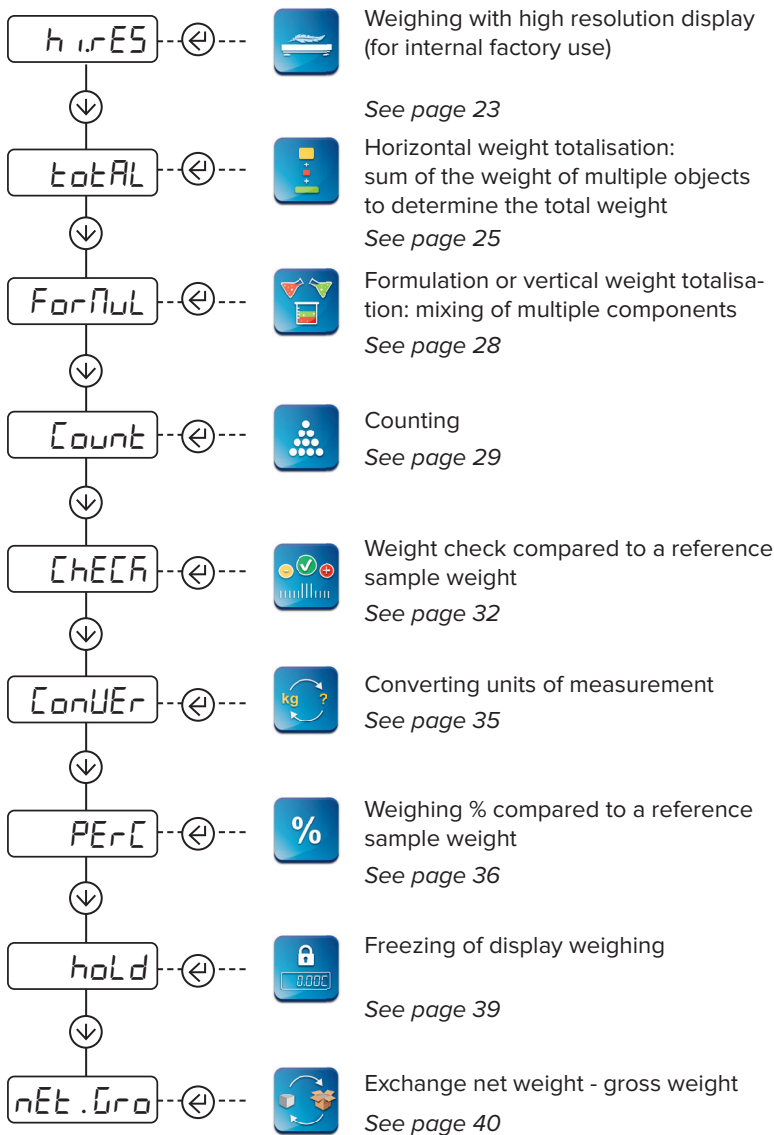

The scale goes back to weighing mode after selecting the function.

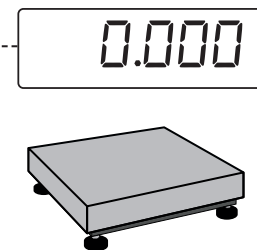



## WEIGHING WITH HIGH RESOLUTION VIEW - *h.r.E5*

### How to check calibration, if necessary

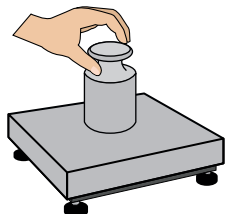

0.201 kg

### How to adjust calibration, if necessary

a.



b.

000.200

Set sample weight (\*)

How to set the value



c.



d.

LoAd

e.

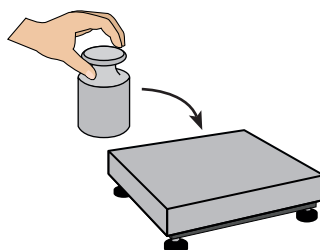

f.

unLoAd

g.

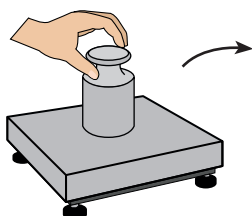

h.

CAL.O

i.

CAL.oF

(\*) The weight used may not differ by more than 2 % from the weight by which the scale was calibrated.  
Check the performed calibration

## WEIGHING WITH HIGH RESOLUTION VIEW - h.r.E5



### How to choose the desired reading division

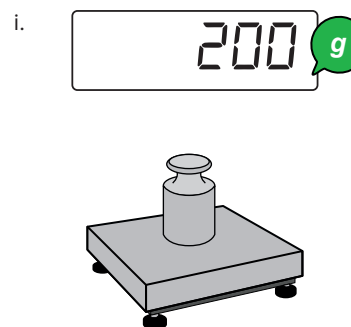
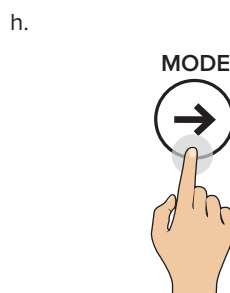
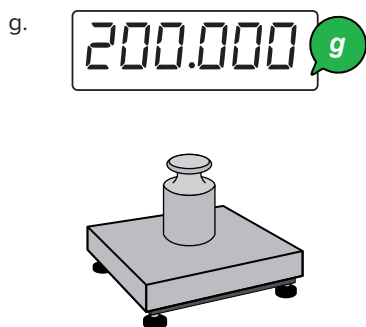
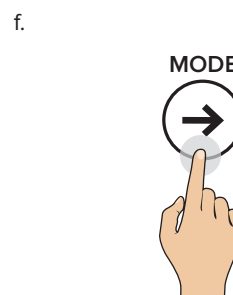
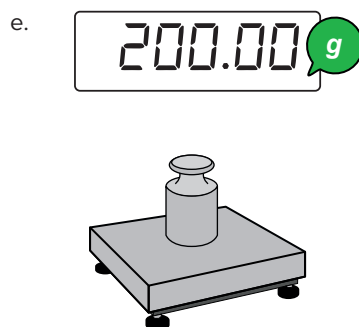
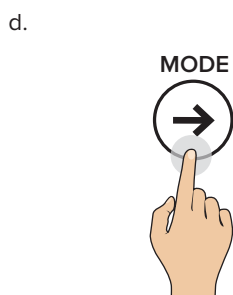
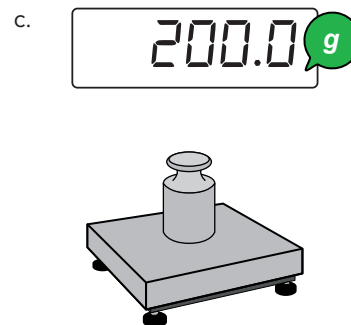
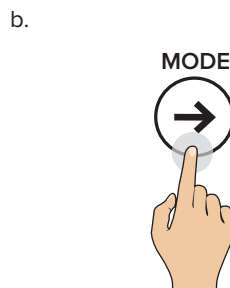
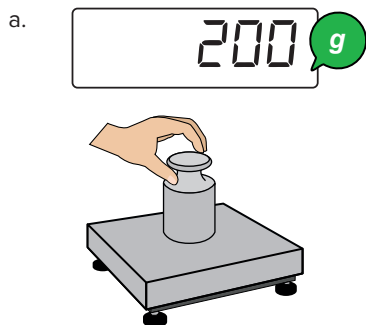

**i**

This operating mode requires the configuration of an appropriate filter (h.r.E50...h.r.E57) (See page 25).  
The maximum number of decimal places that can be displayed is 3.





## HORIZONTAL WEIGHT TOTALISATION - totAL

### How to sum the weighs

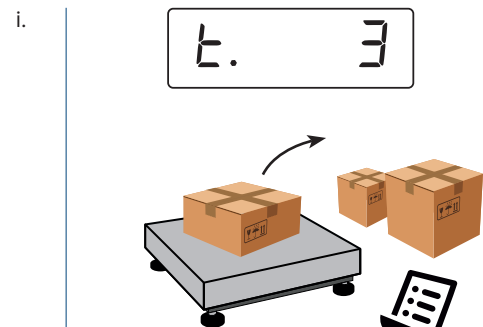
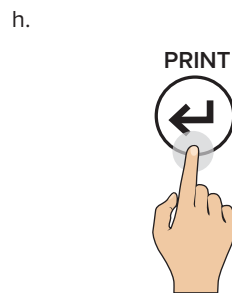
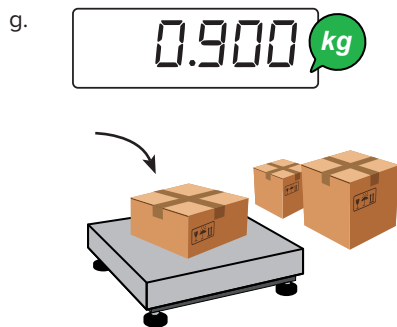
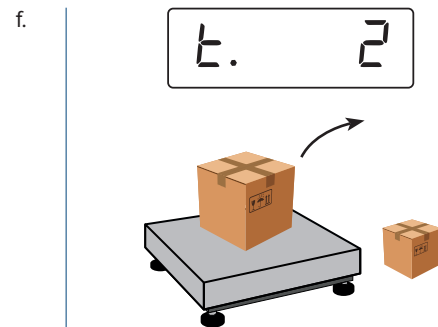
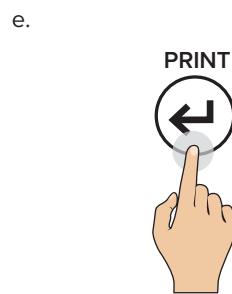
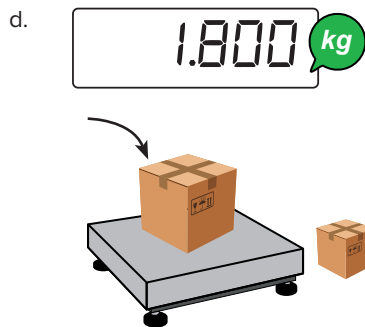
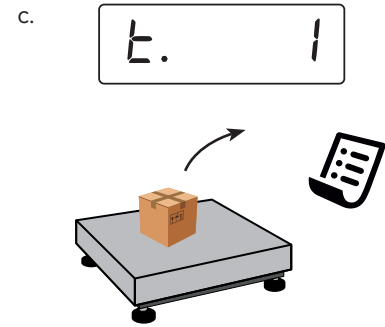
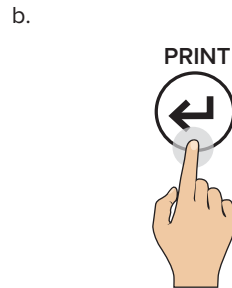
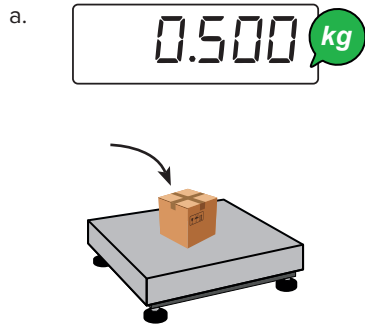

## HORIZONTAL WEIGHT TOTALISATION - Total



### How to momentarily read the total

a.



b.

n. 3

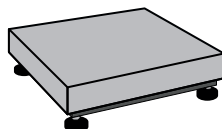

Number of weighs

3.200 kg

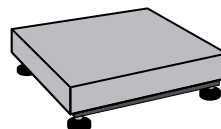

Total weight



**i**

With a numeric keypad, the (F) + (7) key combination displays the current total without printing/resetting it.

### How to end weight totalisation and zero the total

a.



b.

n. 3

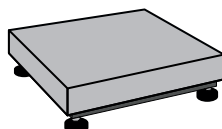

Number of weighs

3.200 kg

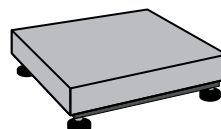

Total weight



**i**

With a numeric keypad, the (F) + (7) key combination displays the current total without printing/resetting it.

### How to print and zero the grand total

a.



b.

n. 3

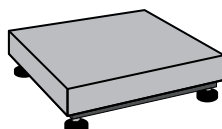

Number of weighs

3.200 kg

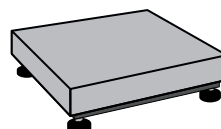

Total weight



**i**

With a numeric keypad, the (F) + (6) key combination displays the current total without printing/resetting it.



## MIXING OF MULTIPLE COMPONENTS - ForNuL

### How to sum the weighs

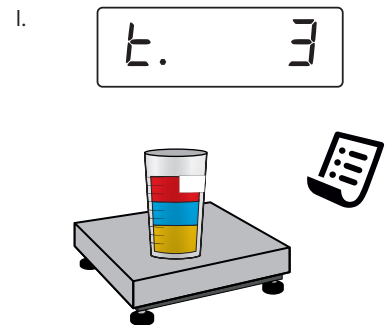
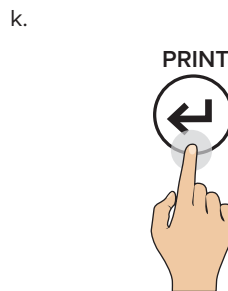
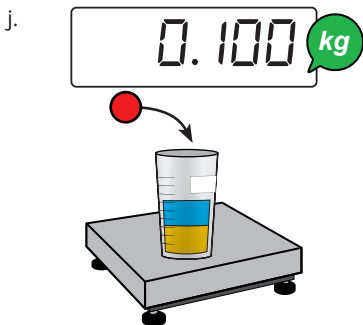
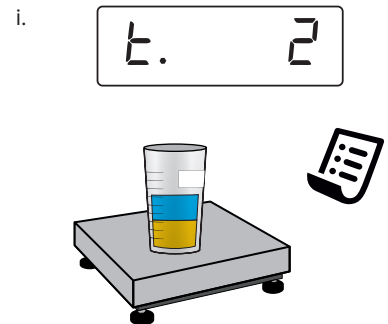
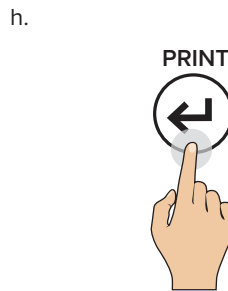
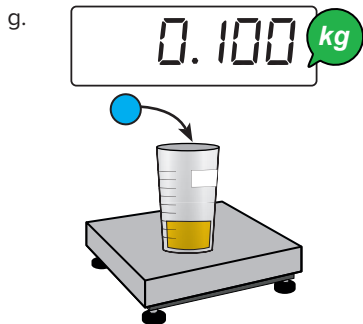
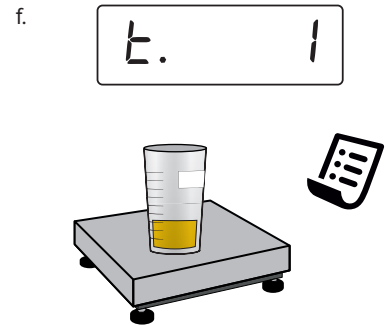
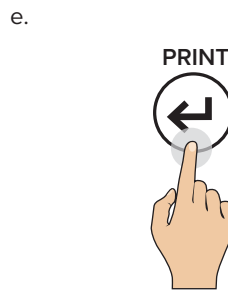
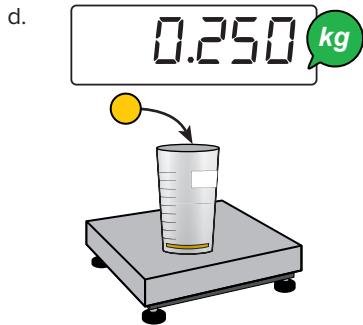
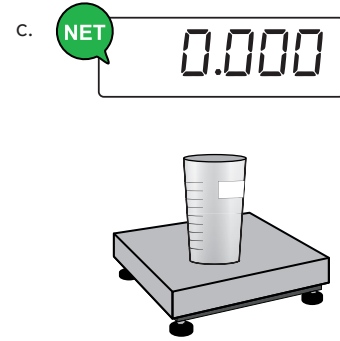
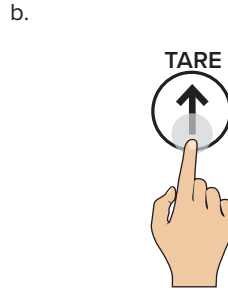

## MIXING OF MULTIPLE COMPONENTS - ForFluL



### How to momentarily read the total

a.



b.

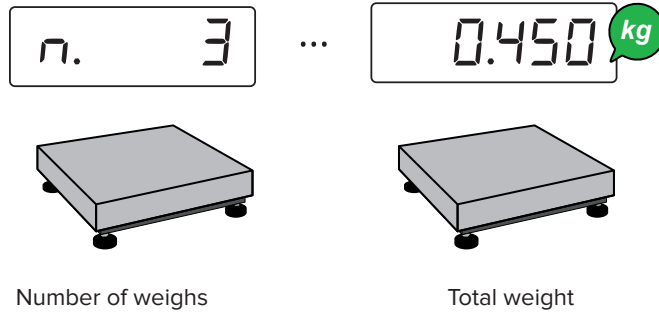

**i**

With a numeric keypad, the **(F) + (7)** key combination displays the current total without printing/resetting it.

### How to reset the total

a.



b.

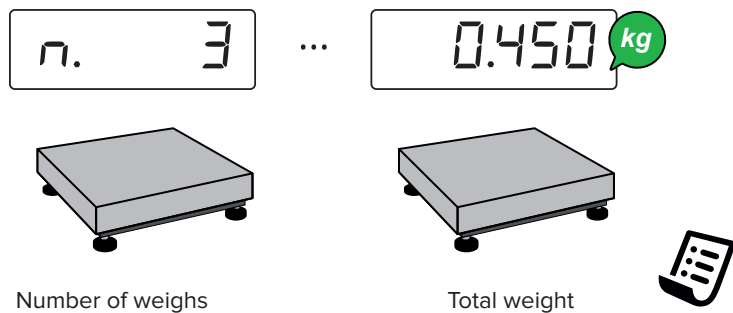

**i**

With a numeric keypad, the **(F) + (7)** key combination displays the current total without printing/resetting it.

### How to print and zero the grand total

a.



b.

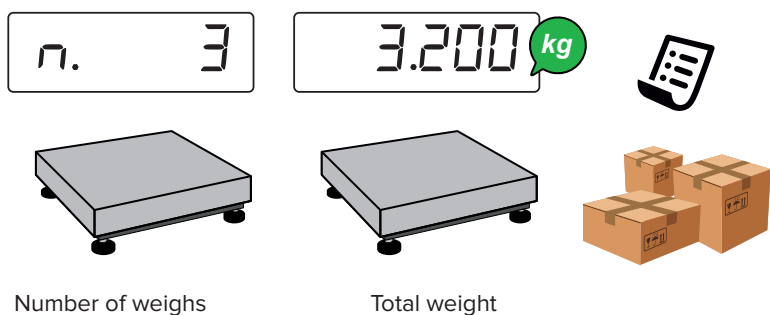

**i**

With a numeric keypad, the **(F) + (6)** key combination displays the current total without printing/resetting it.



COUNTER - Count

How to sample and count

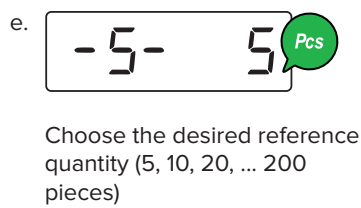
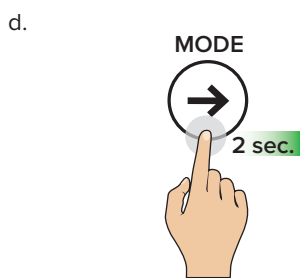
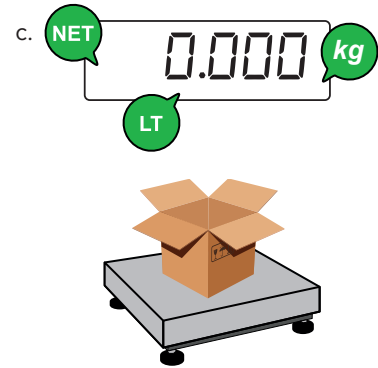
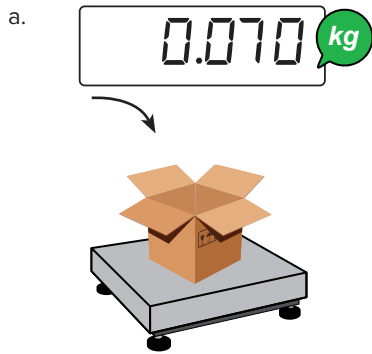

How to set the value



With a numeric keypad, the **F** + **5** key combination can be used to enter a free amount.

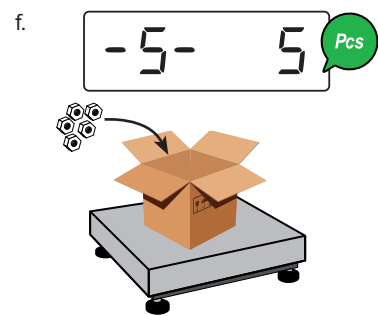

Load the chosen reference quantity  
For correct sampling, the reference quantity must have a weight of at least 0.1% of the maximum capacity of the scale.

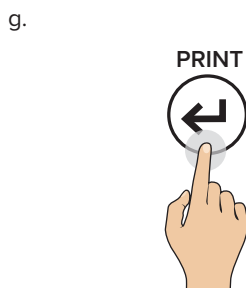

Sampling in progress, please wait...

(\*) With a numeric keypad, the **F** + **7** key combination can be used to edit the sampling time.

The longer the time, the greater the sampling accuracy.

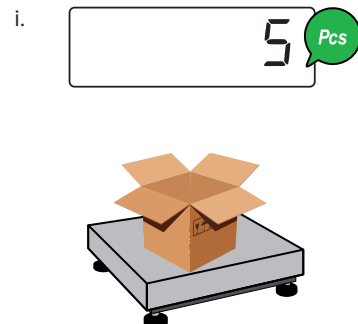

## COUNTER - Count



### How to switch from displaying counter to weight and vice versa

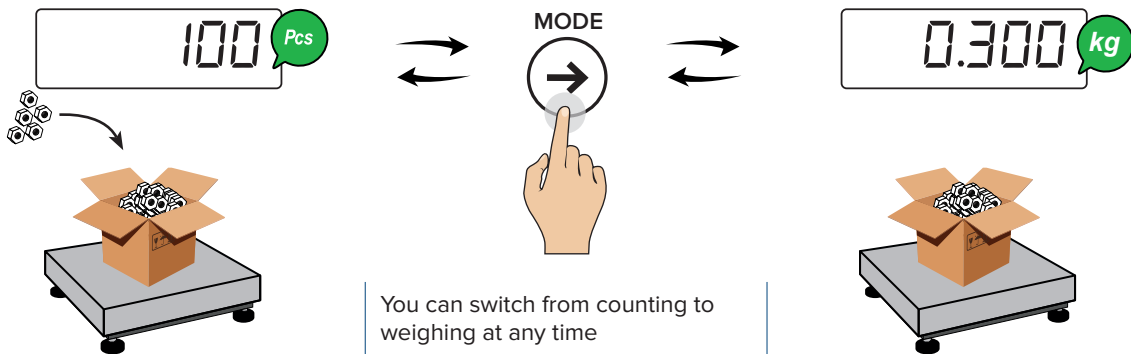

### How to enter the average unit weight (APW)

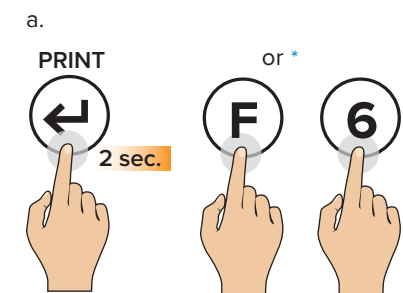

\* With a numeric keypad, the shortcut **F** + **6** can be used.



Enter the average unit weight

Example: = 0.010 kg

How to set the value

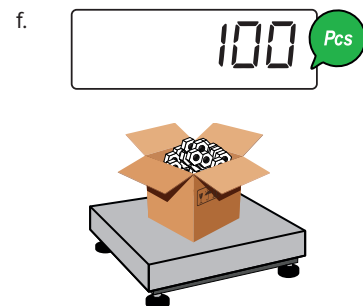
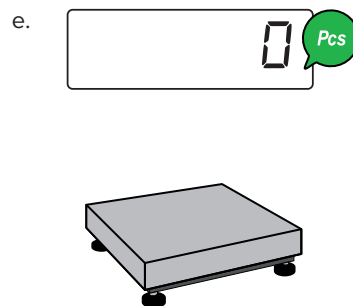
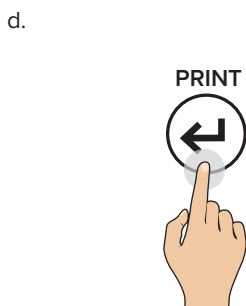

The known tare value must be set to obtain the correct count (see page 15). Alternatively, tare the empty container and fill it with the parts to be counted.



## COUNTER - Count

### Total load counting

a.

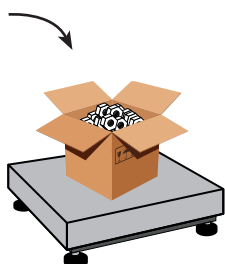

b. Manually set the tare value (container weight).



How to set the value



c.

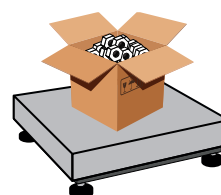

d.

e.

Choose the desired reference quantity (5, 10, 20, ... 200 pieces)

How to set the value



With a numeric keypad, the **F** + **5** key combination can be used to enter a free amount.

f. Take the sampling pieces (5, 10, 20, 30, 40, 50, 60, 75, 100, 200 pieces).

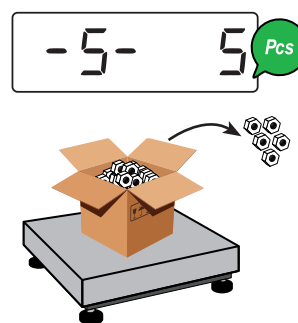

g.

h.

Sampling in progress, please wait...

\* With a numeric keypad, the **F** + **7** key combination can be used to edit the sampling time. The longer the time, the greater the sampling accuracy.

i.

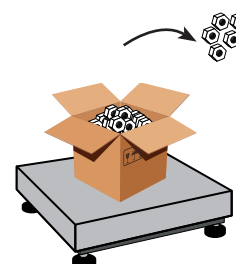



## WEIGHT CHECK - CHECK

### How to start the check with known reference weight

a.

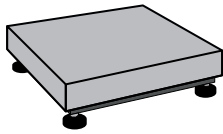

b.

c.

d.

How to set the value



e.

f.

Enter the lower tolerance



g.

h.

Enter the higher tolerance

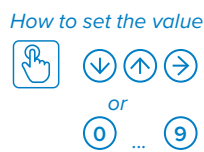

i.

#### Example 1

To check a weight of 1000 g with +/- 5 g tolerance (that is, between 995 g and 1005 g), set:

t0 1000  
L 00005  
h 00005

#### Example 2

To check a weight of 500 g with + 10 g / - 20 g tolerance (that is, between 480 g and 510 g), set:

t00500  
L 00020  
h 00010





## WEIGHT CHECK - CHECK

### How to start the check with automatic target acquisition

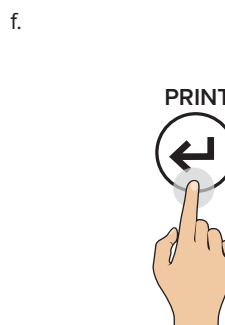
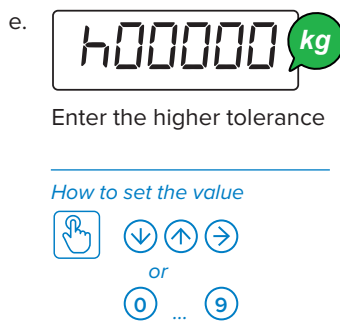
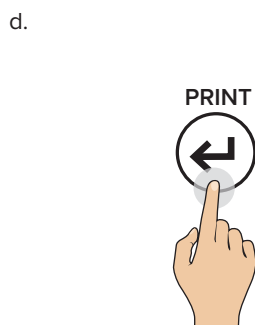
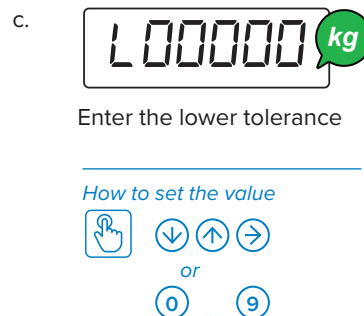
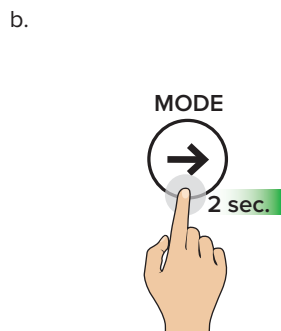
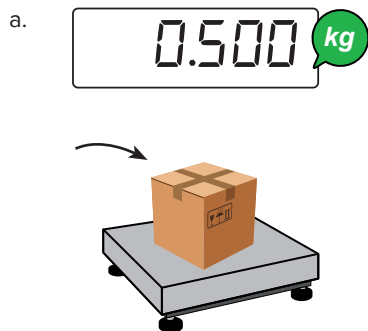

### How to check the weight

- off -

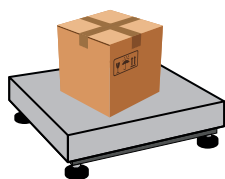

\_ under

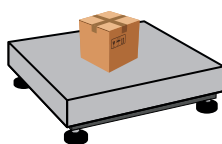



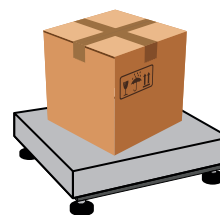

- over





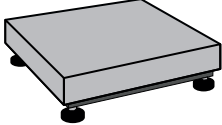

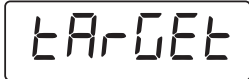
## WEIGHT CHECK - CHECK



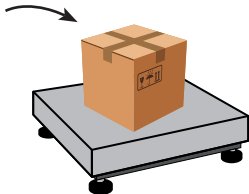

### How to update the nominal weight with known reference weight

- a.  
- b. 
- c.   

### How to update the nominal weight with automatic target acquisition

- a.  
- b. 

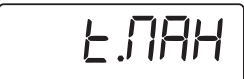
### How to edit the check thresholds

- a. 
- b. 
- c. 
- d. 
- e. 



## UNIT OF MEASURE CONVERSION - ConVEr

### How to convert the unit of measurement to pounds (standard mode)

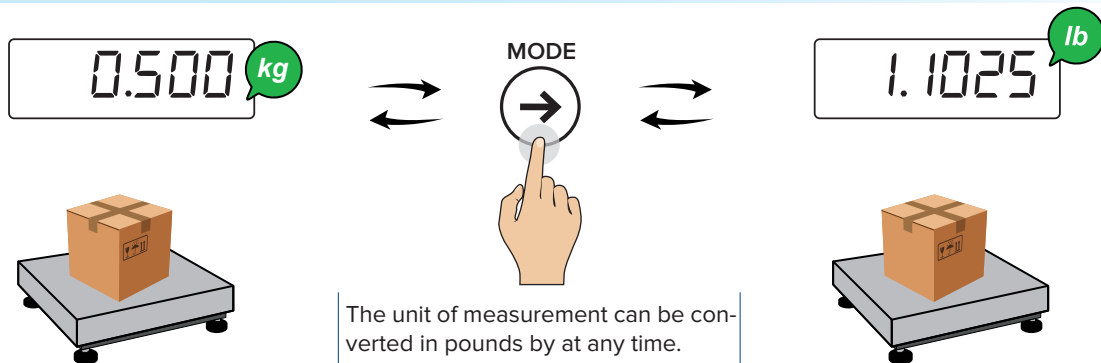

### How to convert the unit of measurement with free conversion factor

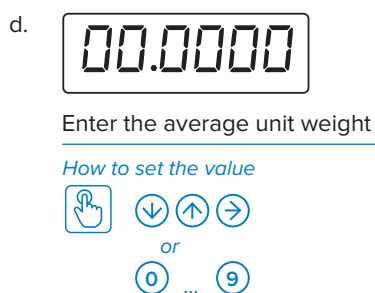
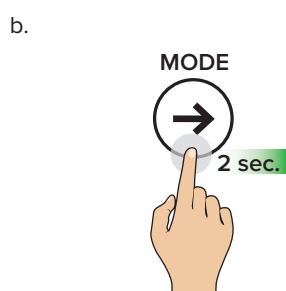
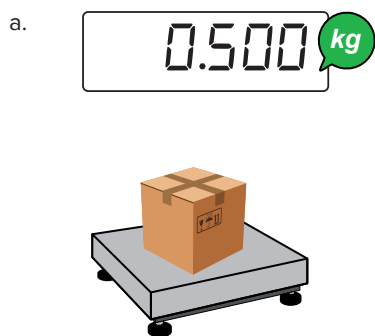

Pounds (lb)	1g = 0.00220
Ounces (oz)	1g = 0.03527
Stones (st)	1g = 0.00016
Carats (kt)	1g = 5.00000
Grain (gr)	1g = 15.43240
...	

*Any conversion factor is multiplied by weight.*

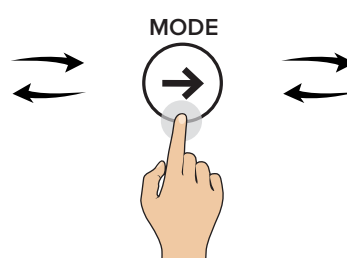
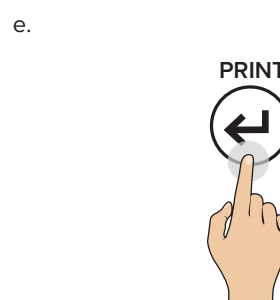

By at any time, the unit of measurement can be converted with a free conversion factor.

PERCENTAGE WEIGHING - PE-C



Percentage control

I. How to acquire the 100% reference

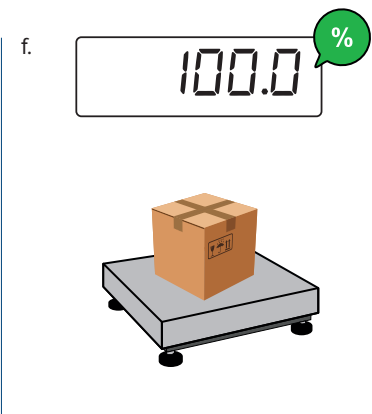
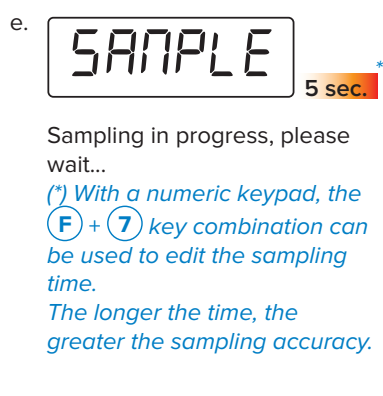
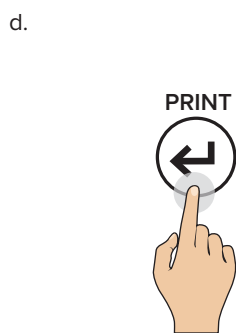
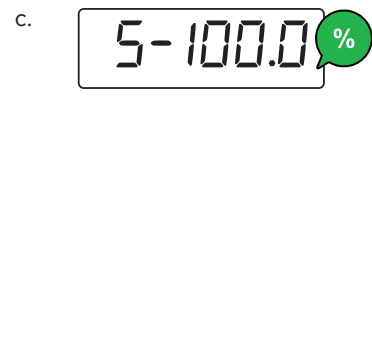
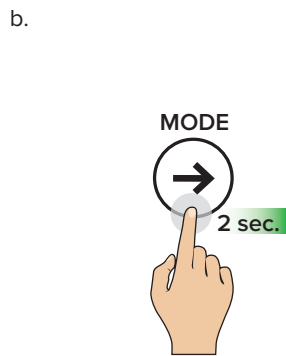
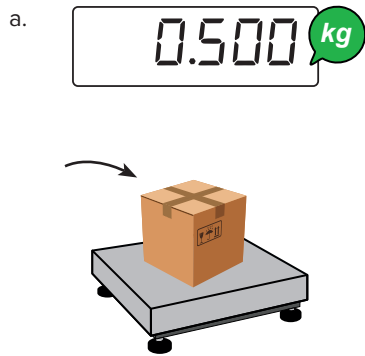

II. How to check the weight

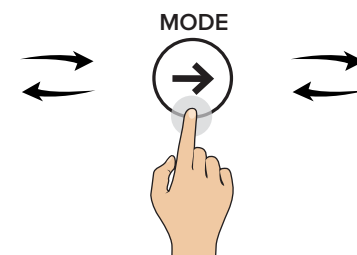
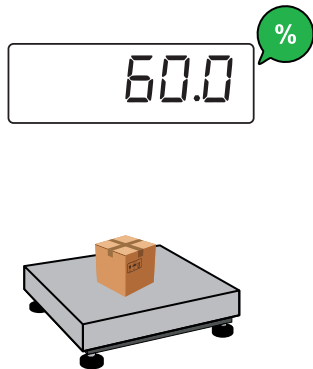

By at any time you can switch from weight % to weight in kg.





**PERCENTAGE WEIGHING - PERC**

**Dosage percentage**

Example of formula

**Product: RP28K**  
 1. 2127A3 - 50%  
 2. 23AB4 - 30%  
 3. Water - 20%  
**Dose 500g**

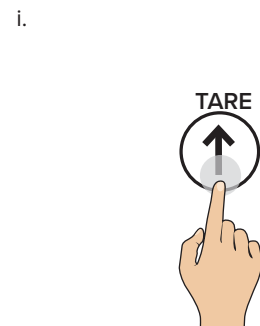
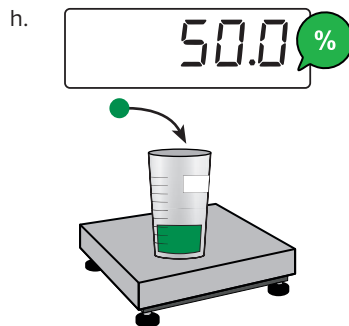
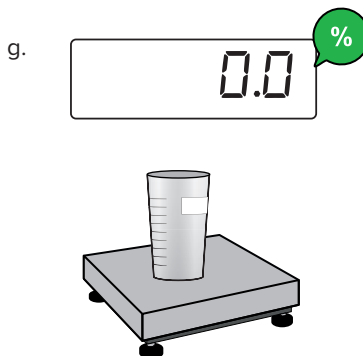
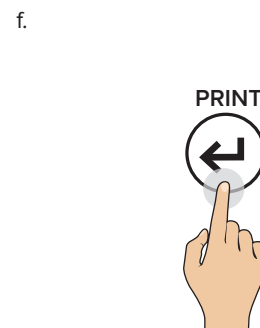
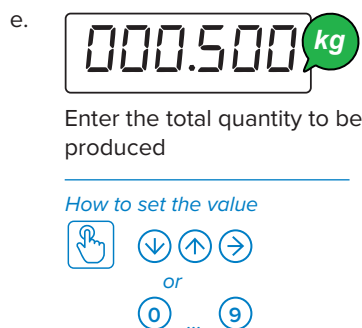
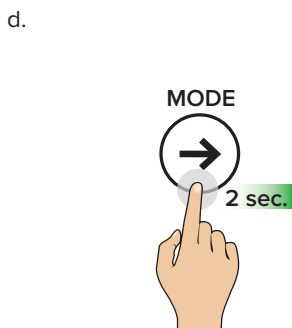
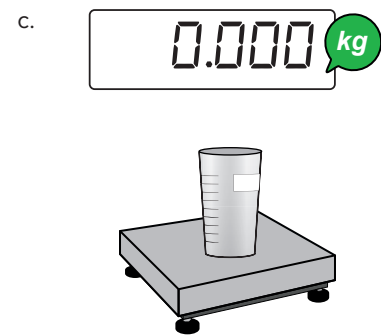
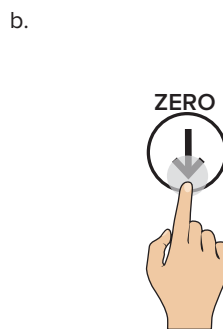
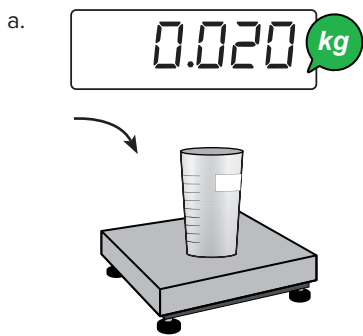

PERCENTAGE WEIGHING - PERC

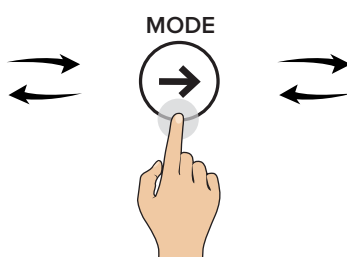
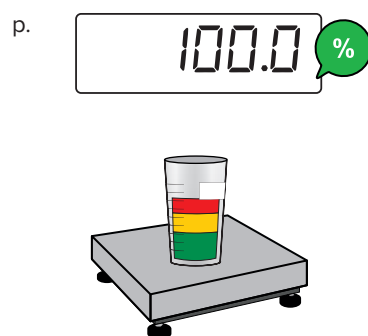
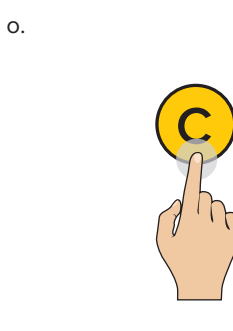
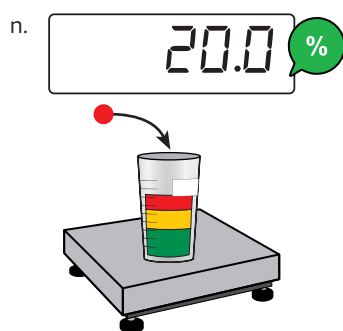
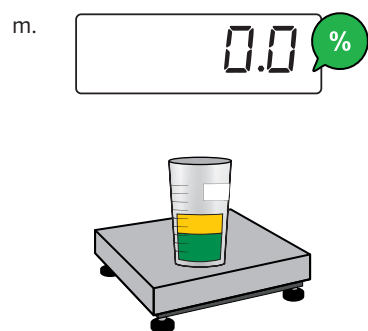
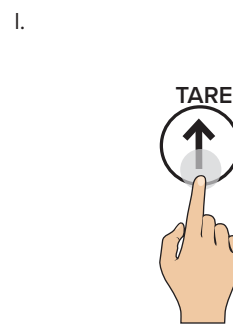
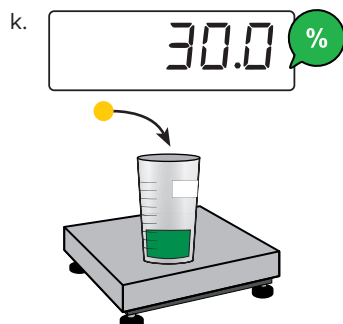
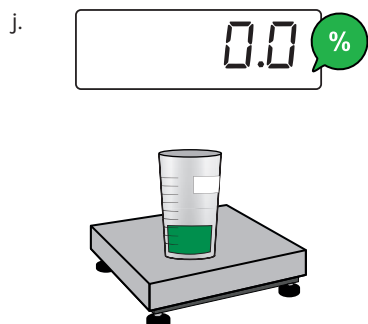

By at any time you can switch from weight % to weight in kg.





## FREEZING OF WEIGHING ON DISPLAY - hold

### How to activate the function

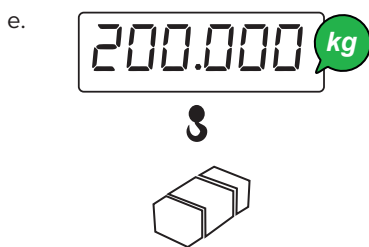
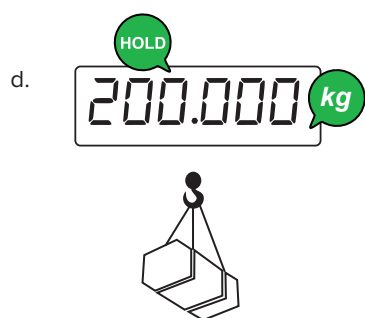
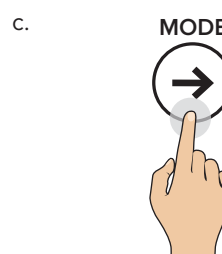
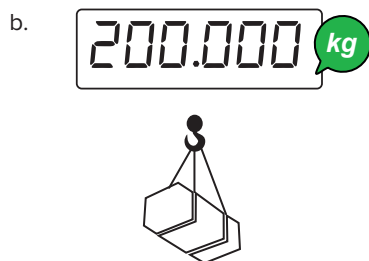
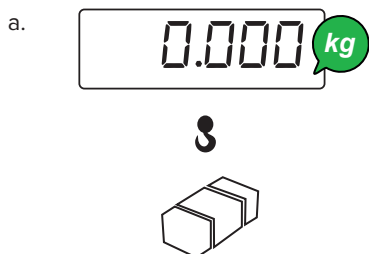

The weight on the display remains frozen even when the scale is empty.

### How to deactivate the function

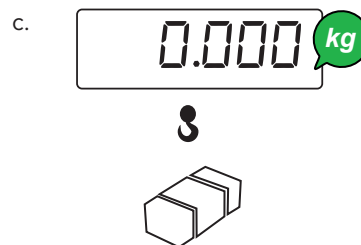
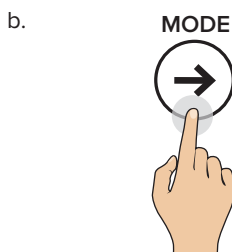
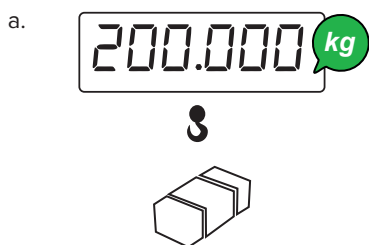

## EXCHANGE BETWEEN NET WEIGHT AND GROSS WEIGHT- *net .Gross*

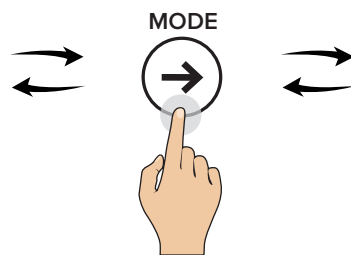
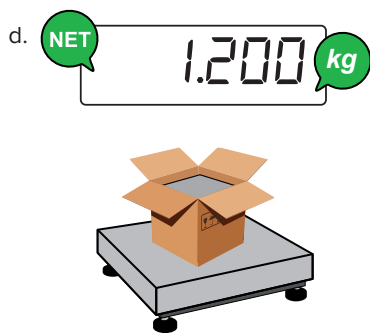
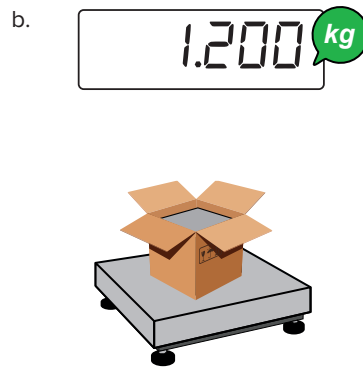
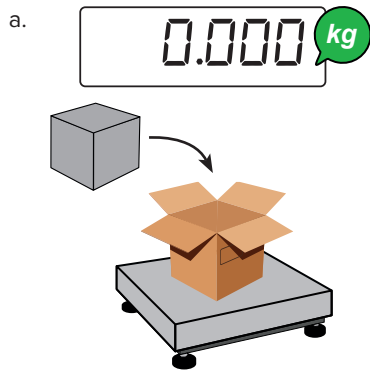
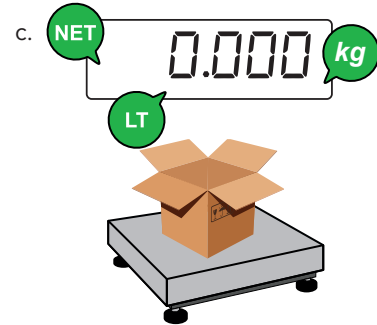
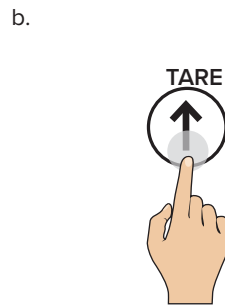
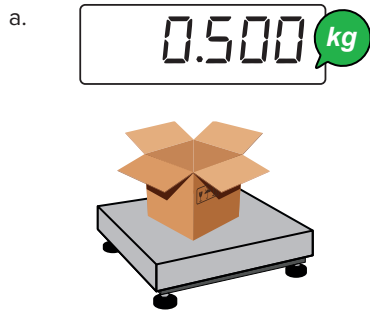

By at any time, you can change from net to gross weight

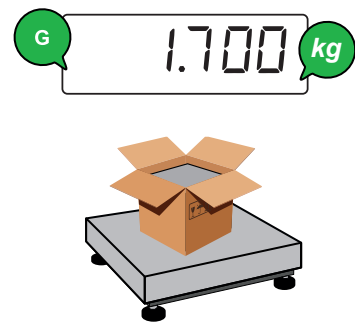





# ⚙️ CONFIGURATION MENU of the scale

How to access the configuration menu .....	41
Date and time (CLoCk).....	42
High resolution reading division (PREC . 10).....	42
Reading the alibi memory (ALibi).....	43
Relay outputs (SEtPnt).....	43
Weighing filters (FILTEr).....	44
Display backlighting (SCrEEn).....	45
Tare (tArE).....	46
Automatic switch-off (AutoFF).....	46
Resetting the ticket number (tIcK . rES).....	46
Factory configuration reset (rESEt).....	47
Diagnostics (dIAG).....	47

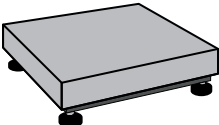
## HOW TO ACCESS THE CONFIGURATION MENU

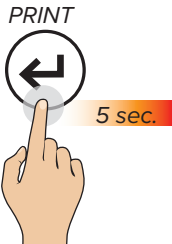
a.  

b. 

c. 

The indicator has entered the configuration menu.



# MENU

How to enter

1. 5 Sec.



How to browse

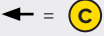
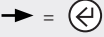
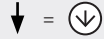
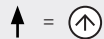

Page 42

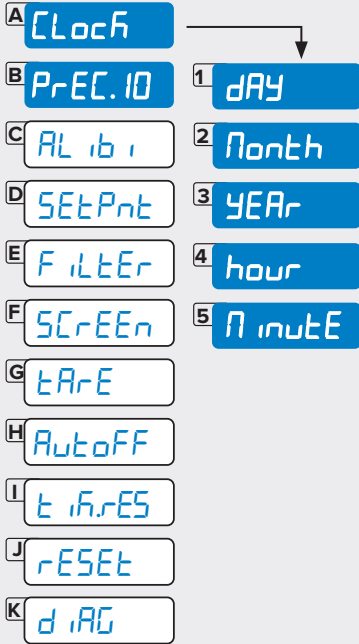

## CLock - DATE AND TIME



Only visible if date/time option is present

Day

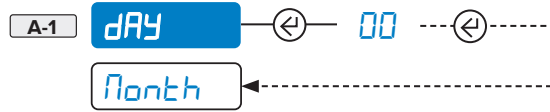

Month

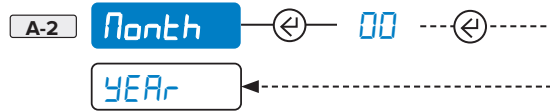

Year

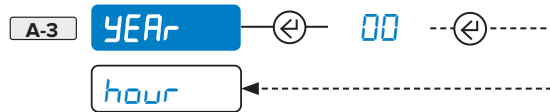

Hour

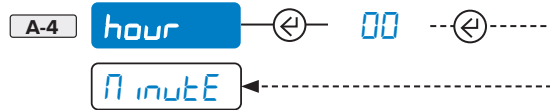

Minute

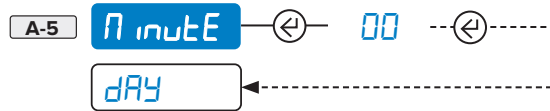

## PrEC.10 - HIGH RESOLUTION READING DIVISION



This functions allows you to display the weight with ten times greater resolution.

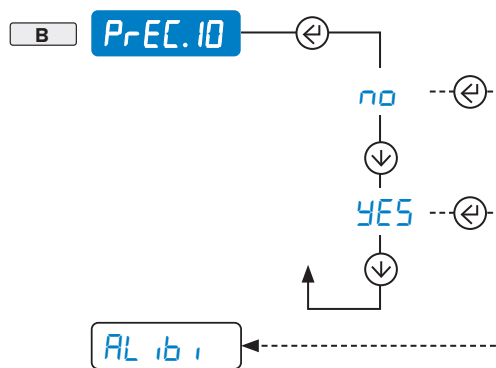



# MENU

How to enter

1. 5 Sec.



Page 42

How to browse

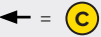
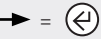
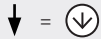
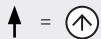

A CLock

B PrEC.10

C ALibi

D SEtPnt

E FiltEr

F SCrEEn

G tArE

H AutoFF

I tArES

J rESEt

K d,AG

## ALibi - READING THE ALIBI MEMORY



Only visible if optional board is present

The weighing storage ID code is expressed as follows:  
00000 - 000000, e.g. 00001 - 000021.

The first value is the rewrite number, the second value is the weighing identification number.

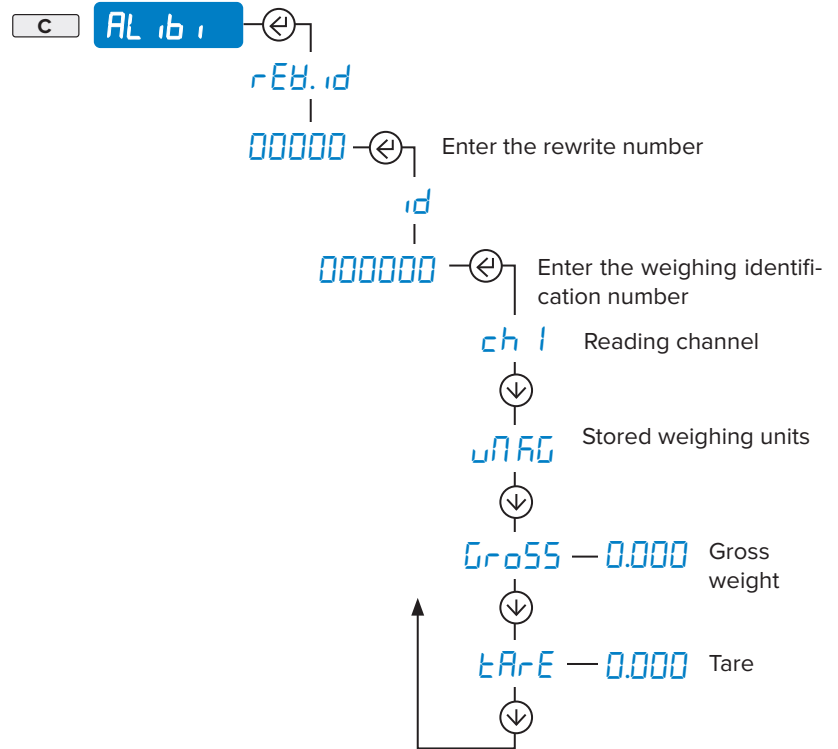

## SEtPnt - RELAY OUTPUTS



Only visible if optional board is present

Activation/deactivation weights for relay outputs

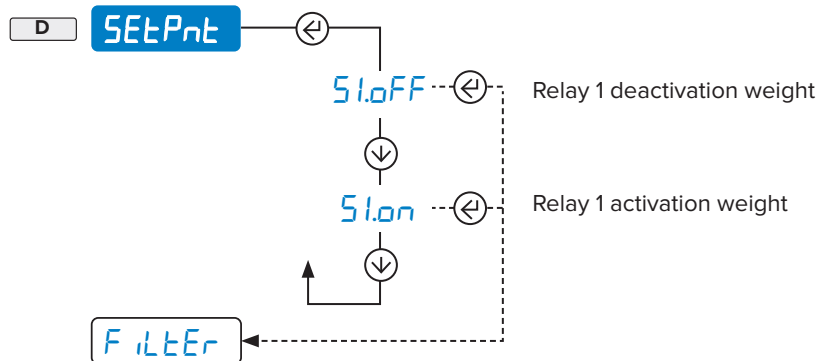

Repeat the operation for each relay.



How to enter

1. 5 Sec.



 Page 42

How to browse



- A **CLock**
  - B **PrEC.10**
  - C **ALib1**
  - D **SEtPnt**
  - E **FILtEr**
  - F **SCrEEr**
  - G **tArE**
  - H **AutoFF**
  - I **tArES**
  - J **rESEt**
  - K **d.rG**
- 1 **F 1**

2 **F 2**

3 **F 3**

4 **F 4**

5 **F 5**

6 **F 6**

7 **F 7**

8 **F 8**

9 **F 9**

10 **F 10**

11 **CuStoN**



To change the responsiveness of the scale.  
This is useful to adjust the scale according to your needs.

 *With an approved instrument, it is not possible to change the filter.*

### Foreword:

"F 10" represents the lowest filtering incidence.

By increasing the incidence, the weight becomes more stable.

It is advisable to carry out several weighing operations by changing the incidence until the best compromise between responsiveness and stability is achieved.

**E-1** **F 1** Filter at 5 Hz.

**E-2** **F 2** Filter at 10 Hz.

**E-3** **F 3** Filter at 20 Hz.

**E-4** **F 4** Filter at 40 Hz.

**E-5** **F 5** Filter at 80 Hz.

**E-6** **F 6** Filter at 160 Hz.

**E-7** **F 7** Filter at 325 Hz.

**E-8** **F 8** Filter at 650 Hz.

 Only visible if  $n.ChPn < 3$

**E-9** **F 9** Filter at 1300 Hz.

 Only visible if  $n.ChPn < 2$

**E-10** **F 10** Filter at 2600 Hz.

 Only visible if  $n.ChPn < 2$

**E-11** **CuStoN** For use by the manufacturer.



# MENU

How to enter

1. 5 Sec.



Page 42

How to browse

↑ =

↓ =

→ =

← =

A CLock

B PrEC.10

C ALib1

D SEtPnt

E FiltEr

F SCrEEen

G tArE

H AutoFF

I tArES

J rESEt

K d.rAG

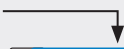

1 bAR.L it

2 LoCk

3 CoLour

## SCrEEen - ADJUSTING THE DISPLAY



### Backlighting

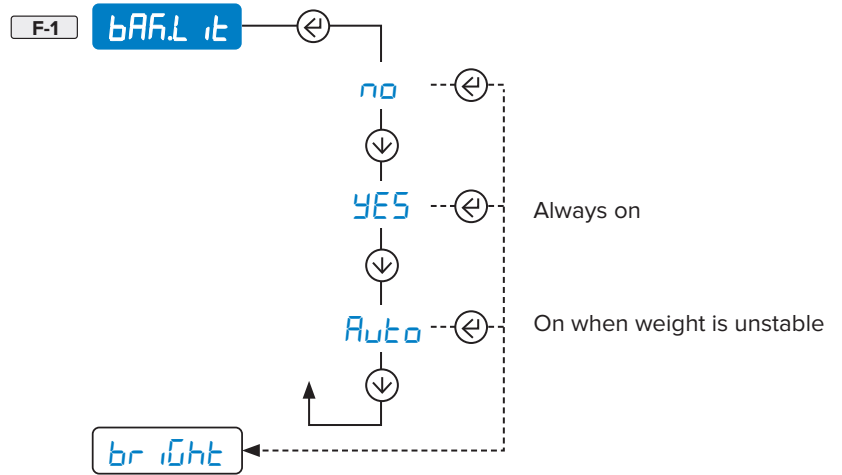

### Display lock (for use by the manufacturer)

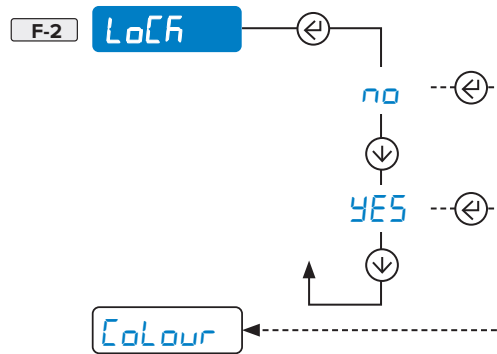

### Backlight colour

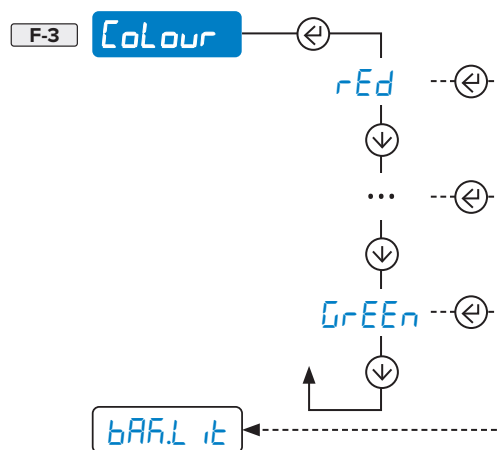



# MENU

How to enter

1. 5 Sec.



Page 42

How to browse



A CLock

B PrEC.10

C ALib1

D SEtPnt

E FiltEr

F SCrEEr

G tArE

H AutoFF

I tArES

J rESEt

K d.rG

## tArE - TARE

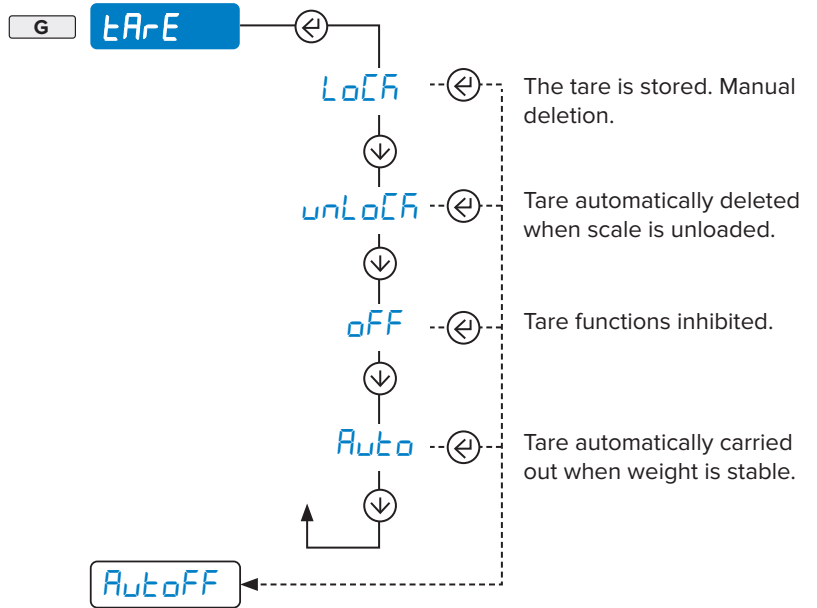

## AutoFF - AUTOMATIC SWITCH-OFF

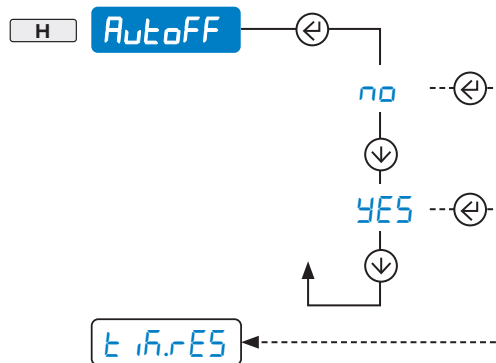

## tArES - TICKET NUMBER RESET

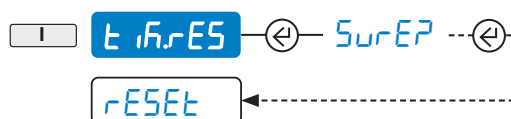



# MENU

How to enter

1. 5 Sec.



Page 42

How to browse

↑ =

↓ =

→ =

← =

**A** CLock

**B** PrEC.10

**C** ALib1

**D** SEtPnt

**E** FiltEr

**F** SCrEEn

**G** tArE

**H** AutoFF

**I** t r r ES

**J** rESEt

**K** d i AG

## rESEt - FACTORY CONFIGURATION RESET

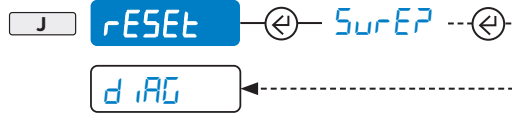

## d i AG - DIAGNOSTICS



**K** d i AG Reserved for technical staff.

# FAQ

## Frequently asked questions

Printing.....	49
Weight totalisation .....	49
Tare .....	49
Weighing.....	50
Counter .....	50



## PRINTING

---

### The scale does not print

- Another printing operation is already in progress (bUSY)
- Check whether a roll is present
- The printer does not turn on
- The weight is unstable (UNStAb)
- The net or gross weight is negative or insufficient for printing (LoH)
- Underload or overload (----- or -----) (un.oUEr)
- The scale was not unloaded after the last printing (no.O.unS)
- You are trying to print a non-approved weight

## WEIGHT TOTALISATION

---

### Scale doesn't total

- Check whether a roll is present
- The printer does not turn on
- The weight is unstable (UNStAb)
- The net or gross weight is negative (LoH)
- Underload or overload (----- or -----) (un.oUEr)
- The scale was not unloaded after the last printing (no.O.unS)
- The weight is not sufficient for weighing (LoH)
  - less than 10 divisions for totalising modes
  - less than "Min" for type-approved products (indicated on the metrology plate)

### The scale lost the total

- Switching off the scale causes loss of accumulated totals

## TARE

---

### The scale does not set the tare

- The weight is unstable (UNStAb)
- The gross weight is negative (LoH)
- The weight is not sufficient
- The weight exceeds the maximum capacity
- The tare function has been deactivated (see page 49)
- In case of manual tare, the value exceeds the maximum capacity

## WEIGHING

---

### The scale does not turn on

- Check the correct connection of the power plug
- Connect the battery charger and try again. If the instrument is still malfunctioning, contact your dealer.

### The scale suddenly switches off

- Auto power off active
- Low battery
- Battery failure
- Power line failure

### The scale is not reactive

- One of the available energy saving modes has been activated
- An unsuitable weighing filter has been selected

### The display of the scale turns off and shows a dot

- Standby mode is active: press a key to reactivate weighing.
- Energy saving is active, contact your dealer for more details.

### The scale displays the message "Err" permanently

- The scale cannot automatically zero the weight because the weight exceeds the maximum weight that can be zeroed at power-up.
- Clear the pan and try again. If the scale has the same problem with the pan unloaded, contact your dealer.

### The weight is unstable

- Check the active weighing filter (*see page 47*).
- If the supporting surface is affected by vibration from moving machinery or equipment, move the scale to another surface and try again.

## COUNTER

---

### The scale does not set sampling

- The weight is unstable (Err . flak)
- The weight is not sufficient, increase the number of pieces and try again (Error)

## ERROR MESSAGES

MESSAGE	DESCRIPTION	SOLUTION
<i>buSy</i>	Another printing operation is already in progress	Wait for the printing operation in progress to be finished and try again.
<i>unStAb</i>	The weight is unstable	Check the active weighing filter (see page 35). If the supporting surface is affected by vibration from moving machinery or equipment, move the scale to another surface and try again.
<i>LoH</i>	The net or gross weight is negative or insufficient for printing	Add weight and try again.
<i>un.oVEr</i>	Underload o overload (____ or _____)	Restore a valid weight condition. If the problem persists, contact customer service.
<i>no.O.unS</i>	The scale was not unloaded after the last printing	Completely unload the scale, making sure the warning light <b>+0+</b> comes on. Reload the weight and try again.
<i>Err.NoSt</i>	The weight is unstable	Wait for stability (the warning light  ) and try again.
<i>Error</i>	In counting mode the weight is not sufficient for proper sampling.	Increase the number of pieces and try again.

## TECHNICAL NOTES - PRODUCT CONFIGURATION

Compiled by the technician, if configuration differs from the factory configuration.

FuncT \_\_\_\_\_

PrEC.10  no  YES

SEtPnt	S1.oFF _____	S5.oFF _____
	S1.oN _____	S5.oN _____
	S2.oFF _____	S6.oFF _____
	S2.oN _____	S6.oN _____
	S3.oFF _____	S7.oFF _____
	S3.oN _____	S7.oN _____
	S4.oFF _____	S8.oFF _____
	S4.oN _____	S8.oN _____

FILtEr \_\_\_\_\_

SCrEEr bAR.Lit  no  YES  Auto  
 LoCk \_\_\_\_\_  
 CoLoUr \_\_\_\_\_

tArE  LoCk  unLoCk  oFF  Auto

AutoFF  no  YES

This publication, or any part of it, may not be reproduced without written permission from the Manufacturer. All information in this manual is based on the data available at the time of its publication; the Manufacturer reserves the right to make changes to its products at any time, without notice and without incurring any penalty. We therefore recommend that you always check for updates.

The person responsible for the use of the scale must ensure that all safety regulations in force in the country of use are applied, ensure that the scale is employed in accordance with the intended use and avoid any dangerous situation for the user.

The Manufacturer declines all responsibility for any weighing errors.



**NOTES**

---

---

---

---

---

---

---

---

---

---

---

---

---

---

---

---

---

---

---

---

---

---

---

---

---





#### **HEAD OFFICE**

Via Della Fisica, 20  
41042 Spezzano di Fiorano, Modena - Italy  
Tel. +39.0536 843418 - Fax. +39.0536 843521  
info@diniargeo.com

#### **SERVICE ASSISTANCE**

Via Dell'Elettronica, 15  
41042 Spezzano di Fiorano, Modena - Italy  
Tel. +39.0536 921784 - Fax. +39.0536 926654  
service@diniargeo.com